

INSTALL IT. TRUST IT.

# ArmaFlex<sup>®</sup> Application manual

[www.armacell.eu](http://www.armacell.eu)



 **armacell**<sup>®</sup>  
ArmaFlex<sup>®</sup>

## Content

<b>General</b> .....	<b>06</b>
<b>Working with ArmaFlex</b> .....	<b>06</b>
<b>Tools for installing ArmaFlex</b> .....	<b>07</b>
<b>ArmaFlex adhesive overview</b> .....	<b>08</b>
<b>The correct use of ArmaFlex adhesive</b> .....	<b>10</b>
<b>Wet sealing butt joints</b> .....	<b>12</b>
<b>Outdoor use of ArmaFlex</b> .....	<b>13</b>
<b>Advice for insulating refrigeration and a/c equipment</b> .....	<b>14</b>
<b>Insulating stainless steel pipes</b> .....	<b>14</b>
<b>Pipes and Fittings</b> .....	<b>15</b>
<b>Insulating pipes using ArmaFlex tubes</b> .....	<b>15</b>
• Cutting ArmaFlex tubes.....	15
• Insulating new pipework using sleeve-on technique.....	16
• Insulating existing pipework using snap-on technique.....	17
• Insulating pipes with ArmaFlex self-seal tubes.....	18
• Insulating pipes with ArmaFlex Ultima self-seal tubes.....	20
• Multi-layer insulation of pipework.....	22
• Using the ArmaFlex template.....	24
• Bend with 90° angle using ArmaFlex tube.....	24
• Bend with 45° angle using ArmaFlex tube.....	24
• Segment bend with 1 middle part - 2+1 using ArmaFlex tube.....	24
• Segment bend with 2 middle parts - 2+2 using ArmaFlex tube.....	24
• Segment bend with 3 middle parts - 2+3 using ArmaFlex tube.....	25
• T-piece using ArmaFlex tube.....	25
• To the videos.....	25
<b>Insulating coupling pipe joints</b> .....	<b>26</b>
• Method 1: oversized 90° bend.....	26
• Method 2: smooth finish 90° bend.....	26

<b>Angle T-piece (off-set) using ArmaFlex tube.....</b>	<b>27</b>
<b>Pipe reducer using ArmaFlex tube .....</b>	<b>28</b>
<b>Insulating pipes with ArmaFlex sheet .....</b>	<b>29</b>
<b>Two-part bend with ArmaFlex sheet .....</b>	<b>32</b>
<b>Valve insulation with ArmaFlex sheet .....</b>	<b>35</b>
<b>Insulating neck-T / pipe-T /spindle neck of valve with ArmaFlex sheet ..</b>	<b>37</b>
<b>Insulating valves with D-box made of ArmaFlex sheet .....</b>	<b>40</b>
<b>Offset angle &amp; pipework bend angle joints .....</b>	<b>43</b>
<b>Strainers, strainer valves &amp; inclined seat valves .....</b>	<b>45</b>
<b>Concentric reducers .....</b>	<b>50</b>
<b>Excentric Reducer .....</b>	<b>51</b>
<b>Two-part bend made of ArmaFlex sheet with extension .....</b>	<b>52</b>
<b>Strainer valve insulation with ArmaFlex sheet.....</b>	<b>53</b>
<b>One-part T-piece with ArmaFlex sheet.....</b>	<b>56</b>
<b>Insulating victaulic couplings with ArmaFlex sheet .....</b>	<b>58</b>
<b>Insulating pumps with ArmaFlex sheet.....</b>	<b>60</b>
<b>Installing ArmaFix insulated pipe supports .....</b>	<b>62</b>
<b>Insulating “over” pipe supports (encapsulating) .....</b>	<b>63</b>
<b>Insulation of other pipe supports .....</b>	<b>64</b>
• Schematic cross-section of a connection of ArmaFlex tubes with a clamp made of pu rigid foam .....	65

<b>Ducts .....</b>	<b>66</b>
<b>Insulating rectangular ducts with ArmaFlex sheet .....</b>	<b>66</b>
<b>Insulating rectangular ducts with ArmaFlex self-adhesive sheet .....</b>	<b>69</b>
<b>Insulating duct brackets with ArmaFlex .....</b>	<b>70</b>
• Insulating duct brackets using ArmaFlex tubes.....	70
• Insulating duct brackets using ArmaFlex sheet.....	71
<b>Insulating circular ducts with ArmaFlex sheet .....</b>	<b>71</b>
<b>Vessels and tanks .....</b>	<b>72</b>
<b>Insulating vessels and tanks with ArmaFlex sheet .....</b>	<b>72</b>
• Draw up a cutting schedule .....	72
• Compression joints .....	72
• Adhesion .....	73
• Multi-layer application.....	74
• Complex shapes.....	74
• Outdoor installations.....	74
<b>Insulating small (<math>\varnothing &lt; 1.5</math> m) tanks and vessels using ArmaFlex sheet ....</b>	<b>75</b>
<b>Key basic application procedures for large vessels <math>\varnothing &gt; 1.5</math> m.....</b>	<b>77</b>
<b>Vessel insulation with metal jacket .....</b>	<b>79</b>
<b>Additional application advice .....</b>	<b>81</b>
<b>ArmaFlex with additional metal cladding.....</b>	<b>81</b>
<b>ArmaFlex installed in the soil.....</b>	<b>81</b>
<b>Installation of ArmaFlex insulation on plastic pipes .....</b>	<b>82</b>
<b>References.....</b>	<b>83</b>
• Insulation of stainless steel with ArmaFlex .....	83
• Corrosion protection in thermal and refrigeration insulation on technical operating systems.....	83
• ArmaFlex cold work application guidance .....	83
• Gluing ArmaFlex onto cellular glass .....	83
• Other application guides .....	83
<b>Calculation tools.....</b>	<b>83</b>
• ArmWin .....	83

**ArmaFlex products ..... 84**











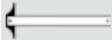

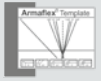

- AF/ArmaFlex..... 84
- AF/ArmaFlex Evo ..... 84
- SH/ArmaFlex ..... 84
- HT/ArmaFlex ..... 84
- NH/ArmaFlex..... 84
- NH/ArmaFlex Smart ..... 84
- ArmaFlex Ultima ..... 85
- ArmaFlex DuoSolar ..... 85
- ArmaFix pipe support..... 85
- ArmaFlex accessories ..... 85

# General

## Working with ArmaFlex

- Use good quality tools, in particular sharp knives, fresh ArmaFlex adhesive, ArmaFlex Cleaner and brushes.
- Oval tubes should always be split on the flat side.
- Use clean ArmaFlex material – with no dust, dirt, oil or water on the surface, if present clean with ArmaFlex cleaner.
- Use correctly dimensioned material! Never pull glued joints when sealing them, always push them together.
- Never insulate plant and systems that are in operation.
- In general an additional use of ArmaFlex tape is not necessary. Self-adhesive ArmaFlex tape should not be used as the sole fixing for butt and longitudinal joints and seams. If required it should only be applied to joints and seams that have previously been glued with ArmaFlex adhesive and only after 24, 36 and 72 hours to allow complete outgassing of the adhesive solvent.
- Armafinish 99 paint can be applied immediately after the insulation has been installed, with a second coat of paint applied within 7 days, to provide UV protection (see “Outdoor use of ArmaFlex” on page 13).
- ArmaFlex (with the exception of HT/ArmaFlex and NH/ArmaFlex Smart) must not be exposed to the weather without protection for more than 3 days.

## Tools for installing ArmaFlex

	Folding rule / tape measure		Straight edge
	Chalk for marking irregular shapes		Template (printed on every ArmaFlex carton)
	Silver ink marker pen		Scissors
	Dividers		Brushes with short, firm bristles
	Callipers		Smooth spatula
	Short knife* 75mm		Sharpened pipe ends for the most common pipe diameters
	Long knife* 300mm		Rollers for surface gluing
	Sharpening stone*		Gluemaster

\* A three knife set plus sharpening stone are available together as a tool kit.

Property	ArmaFlex® 520	ArmaFlex 525	ArmaFlex ECO550
<b>Short description</b>	Special ArmaFlex adhesive	Special ArmaFlex premium adhesive	Solvent-free polychloroprene contact adhesive as single-component or two-component adhesive
<b>Special features</b>	General use adhesive	Special adhesive for next generation ArmaFlex, synthetic rubber	A specially formulated adhesive for uniform, safe seam bonding of flexible ArmaFlex insulation materials, excluding EPDM foams
<b>Service temperature</b>	-50°C to +105°C	-50°C to +110°C	-30°C to +100°C
<b>Minimum airing time</b>	3 - 5 minutes	3 - 5 minutes	2 - 3 minutes 1 - 2 minutes with ArmaFlex ECO550 Activator
<b>Maximum dry time</b>	15 - 20 minutes	15 - 20 minutes	15 - 20 minutes
<b>Setting time</b>	36 hours	36 hours	36 hours
<b>Application temperature</b>	ideally +15 to +20°C not below 0°C	ideally +15 to +20°C not below 0°C	ideally +15 to +20°C not below +5°C
<b>Shelf life</b>	18 months	18 months	12 months
<b>Packaging</b>	Tin can 250 ml / 500 ml 1000 ml / 2500 ml	Tin can 500 ml 1000 ml / 2500 ml	Plastic container 300 gr

## Product name

ArmaFlex Ultima (C, ACR, ArmaFix Ultima)			
AF/ArmaFlex Evo (ArmaFix AF)		●	●
AF/ArmaFlex (ArmaFix AF)	●	●	●
NH/ArmaFlex Smart (ArmaFix NH Smart)			
ArmaFlex SE		●	●
ArmaFlex ACE Plus (S)	●		●
SH/ArmaFlex	●	●	●
ArmaFlex Protect	●	●	
ArmaFlex Rail SD/C			
ArmaFlex Rail ZH	●		●
ArmaFlex Rail ZH/C			
HT/ArmaFlex (S)			
ArmaFlex Duct (Plus, AL, Plus AL)	●		●
ArmaFlex DuoSolar			
ArmaFlex HP	●	●	●
ArmaLight Tubolit	●		
ArmaClad Arma-Chek (D, R, Silver)	●	●	
ArmaComfort AB (Alu, Plus, Alu Plus)	●		
ArmaComfort NH-S			
ArmaSound RD 120/240 (Barrier, E)	●		
ArmaFlex Tuffcoat	●		●

ArmaFlex Ultima ECO550	ArmaFlex Ultima 700	ArmaFlex RS850	ArmaFlex HT625	ArmaFlex 750
Solvent-free polychloroprene contact adhesive as single-component or two-component adhesive	Special adhesive for ArmaPrene® synthetic rubber	Non-drip thixotropic adhesive	High temperature, industrial grade adhesive	Contact adhesive on polychloroprene basis, free of aromatic solvent
A specially formulated adhesive for uniform, safe seam bonding of ArmaFlex Ultima and ArmaPrene-based insulation materials	Specially formulated for maximum compatibility with products based on ArmaPrene synthetic rubber	Thixotropic gel, non-drip adhesive for faster and cleaner application	High performance adhesive for a wide range of temperatures and applications	A specially formulated adhesive for uniform, safe seam bonding of flexible NH/ArmaFlex Smart insulation materials
-30°C to +100°C	-50°C to +110°C	-40°C to +70°C	-50°C to +150°C	-50°C to +90°C
2 - 3 minutes 1 - 2 minutes with ArmaFlex ECO550 Activator	3 - 5 minutes	> 2 minutes	3 - 5 minutes	3 - 5 minutes
15 - 20 minutes	15 - 20 minutes	10 - 15 minutes	15 - 20 minutes	15 - 20 minutes
36 hours	36 hours	24 hours	36 hours	36 hours
ideally +15 to +20°C not below +5°C	ideally +15 to +20°C not below 0°C	ideally +15 to +20°C not below +10°C	ideally +15 to +20°C not below 0°C	ideally +15 to +20°C not below 0°C
12 months	18 months	36 months	18 months	18 months
Plastic container 300 gr	Tin can 1000 ml	Tin can 500 ml	Tin can 250 ml / 500 ml 1000 ml	Tin can 500 ml

•	•			
•		•		
•		•		
		•		•
•		•		
•		•		
•		•		
•	•	•	•	
•	•	•		•
		•		•
•		•		
		•		
•		•		
		•		
		•		
		•		
	•	•	•	•
•	•	•	•	

## The correct use of ArmaFlex adhesive

### PREPARING FOR WORK

Check condition of ArmaFlex adhesive. Cans of ArmaFlex adhesive should have been stored in a cool environment wherever possible. Cans must also have been kept free from frost. For detailed information about transport, storage and shelf-life see the Product Data Sheet.

1. Where installation surfaces are soiled with dust, dirt, oil or water, all of these contaminants must be removed and, where applicable, the surfaces must be cleaned with ArmaFlex cleaner before starting work. In addition all surfaces to be joined must be dry before gluing begins.
2. Pay close attention to the installation instructions on the adhesive can. Use small cans during work so that the adhesive does not thicken too quickly. Refill from larger cans when necessary and keep closed when not in use to avoid thickening [except ArmaFlex RS850].
3. The ideal installation temperature is 15 °C to 20 °C. Do not use adhesive under 0 °C (ArmaFlex ECO550 and ArmaFlex Ultima ECO550 5 °C). If the adhesive is too cold, it can be warmed in a bucket of hot water. At temperatures below 5 °C, condensation can appear on the surfaces to be glued or the adhesive film. If this occurs, it is very difficult to glue the materials. Always have a clean cut with ArmaFlex. When necessary, sharpen the cutting tools.
4. Stir adhesive well after opening (applies to adhesives ArmaFlex 520, ArmaFlex 525, ArmaFlex 750, ArmaFlex HT625 and ArmaFlex Ultima 700). If left to stand for longer periods of time, heavier components in the adhesive may settle on the bottom of the can. These must be periodically mixed thoroughly before use in order to effectively activate the adhesive.

### PIPES WITH CORROSION PROTECTION

Check that the adhesive will adhere to any rust-inhibiting primer that has been used to protect pipes. Standard ArmaFlex adhesives should be compatible with all coating systems based on epoxy resin or polyurethane. ArmaFlex adhesive may not adhere to asphalt, bitumen or red lead.

### APPLICATION

1. Use a brush with short, stiff bristles and keep clean. For larger areas a (non-foam) paint roller or the ArmaFlex Gluemaster may be used to speed up application (This does not apply to the ArmaFlex RS850 adhesive).

2. Always apply material under compression. Avoid tension on the seams.
3. Apply ArmaFlex adhesive thinly and evenly onto both surfaces to be glued.
4. When adhering ArmaFlex to other materials (e.g. metal), first apply the adhesive to the ArmaFlex and then to the other clean surface.
5. Allow the adhesive to 'tack dry'. The time required will vary according to the ambient conditions. The correct initial drying time may be determined by the 'fingernail test': touch the surface with a fingernail, if the fingernail does not adhere to the surface and the surface itself does not feel tacky, the joint may be closed. The maximum adhesive force will be obtained when two tack-dry surfaces are brought together.
6. The glued surfaces should be pressed together, not stretched. Do not leave glued seams on the top of the insulation in external locations. When working outdoors, always turn the glued seams away from the sun.
7. When gluing joints under compression, with no gaps present, the wet adhesive method should be used. Pull the seam apart slightly and apply ArmaFlex adhesive thinly and evenly with the brush to both surfaces and press together. No open time is needed in this case.
8. Use ArmaFlex cleaner to clean your tools, contaminated metal surfaces and surfaces where talc has been applied.

**Note:** Do not use ArmaFlex cleaner to make the adhesive thinner. To make the adhesive easier to apply in cold environments, warm it over a bowl of hot water. It is recommended to apply ArmaFlex adhesive according to the safety instructions that are defined on the adhesive tins.

## APPLICATION IN HOT AND HUMID ENVIRONMENTS

High atmospheric humidity and high temperatures lead to faster evaporation of the solvent in ArmaFlex adhesive. This means that a film of moisture may appear on the surface of the adhesive. Consequently the reliability of the adhesive seam cannot be assured as the surfaces to be joined may not bond together.

Under these conditions, the following points may be observed as an alternative to our installation instructions:

- Apply ArmaFlex adhesive as normal in a thin uniform film on both surfaces.
- Unlike normal bonding, the surfaces to be glued should be held together under pressure whilst wet.

**Note:** Due to the shorter curing time, adhesive can only be applied to a limited area at a time. Depending on the atmospheric humidity, temperature, material thickness and practical installation conditions, we recommend a tube length of around 1 m as a guideline.

- To avoid tension within the material and prevent the trapped solvent opening the seam, seams should be held in place with ArmaFlex adhesive tape immediately after gluing. Apply the adhesive tape at right angles to the glued seam every 20 cm or so.

## Wet sealing butt joints

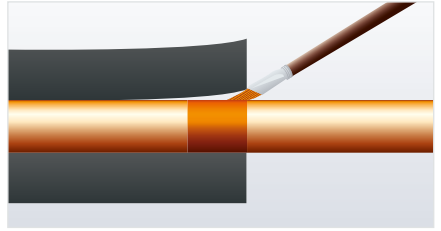

1. On all cold lines, use ArmaFlex adhesive to glue the ends of the ArmaFlex sheets/tubes to the pipe surface.
2. The adhesive should be applied in a width at least equal to the insulation thickness.

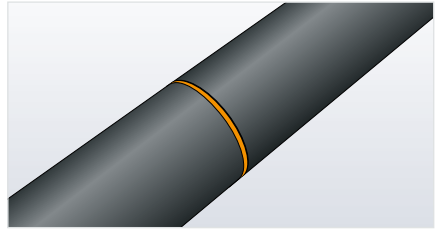
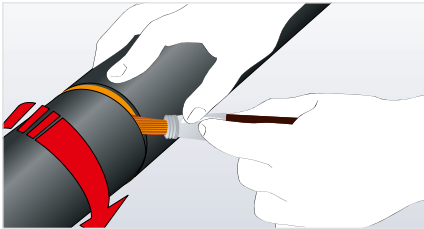

3. For the final wet sealing of the tube/sheet, use fingers to pull the joint apart and apply a thin, even film of adhesive to the two butt joint edges with a small brush.
4. Apply firm and even pressure to the glued joint using fingers and thumbs to finish.

**Note:** In addition, it is highly recommended that this procedure is followed for all other types of hot pipes located outdoors.

## Outdoor use of ArmaFlex

Whenever used, ArmaFlex (with the exception of HT/ArmaFlex and NH/ArmaFlex Smart) must either be painted, covered or clad within 3 days (first coat).

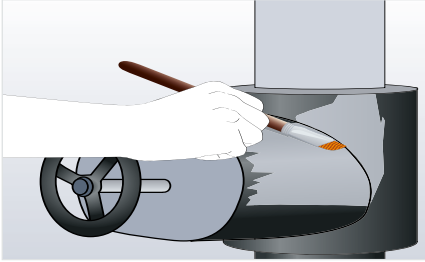

**Armafinish 99** is a water-based protective paint. To provide UV protection, two complete coats must be applied.

The first coat can be applied immediately after the insulation has been installed. The second coat should be applied within 7 days.

### Normal consumption

	l / m <sup>2</sup>	m <sup>2</sup> / l	wet film / mm	dry film / mm
1st coat	0.275	3.6	0.275	0.13
2nd coat	0.275	3.6	0.275	0.13
Total	0.550	1.8	0.550	0.26

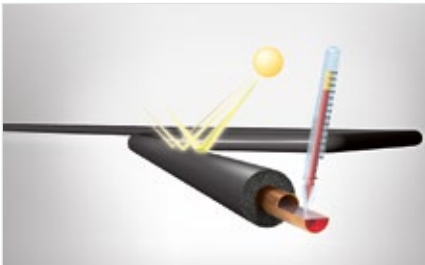

The UV-resistant **HT/ArmaFlex** and **NH/ArmaFlex Smart** can be used for outdoor applications without any additional UV-protection.

If additional mechanical protection or protection against severe weather conditions is required, **Arma-Chek covering systems** offer a non-metallic cladding option (HT/ArmaFlex only with Arma-Chek R: AF/ArmaFlex, AF/ArmaFlex Evo, NH/ArmaFlex, NH/ArmaFlex Smart with Arma-Chek D, Arma-Chek Silver, Arma-Chek Wrap or Arma-Chek R). ArmaFlex Ultima must be protected th a metal cladding in general (e.g. Okabell). For installation details please see the Arma-Chek installation manuals.



## Advice for insulating refrigeration and a/c equipment

- Surfaces of pipes and tanks must be sufficiently protected against corrosion before installing ArmaFlex. In general anti-corrosion systems based on an epoxy and polyurethane resin are compatible with ArmaFlex adhesives. See the section “Pipes with corrosion protection” for more details on compatibility.
- In the case of conventional insulation systems, slight damage to the water vapour barrier can allow moisture to permeate throughout and underneath the insulation material. When using ArmaFlex, this can easily be prevented by attaching each end of the ArmaFlex tube to the pipe with ArmaFlex adhesive, and making sure the adhesive joints are firm at critical points such as flanges, T-sections, elbows, supports, etc.
- By regularly adhering ArmaFlex to the pipe in this way, the insulation system can be compartmentalised. Damage will therefore be limited to the specific section and can easily be detected.
- All connected items of equipment should be insulated with an equal thickness where practical.
- Never insulate chilled-water lines or refrigeration equipment if the sections to be insulated are too close together. Sufficient space should be allowed between insulated objects to ensure free convection, as air movement by free convection provides an additional safeguard against condensation on cold pipes.

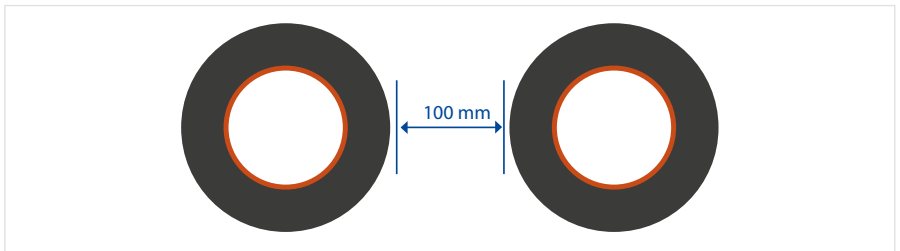

## Insulating stainless steel pipes

When insulating stainless steel with ArmaFlex please consult our Customer Service Department.

# Pipes and Fittings

## Insulating pipes using ArmaFlex tubes

### CUTTING ARMAFLEX TUBES

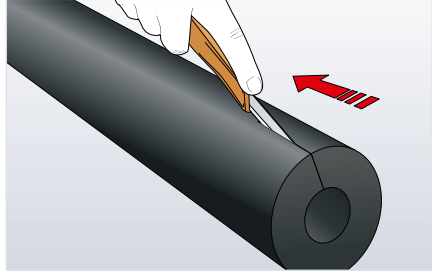
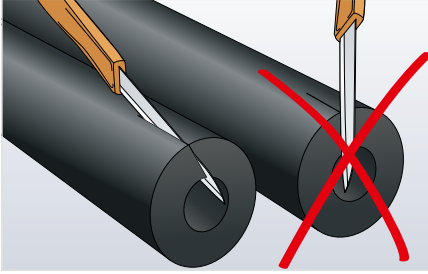

Use a sharp knife. Keep knife at a low angle when slitting tube

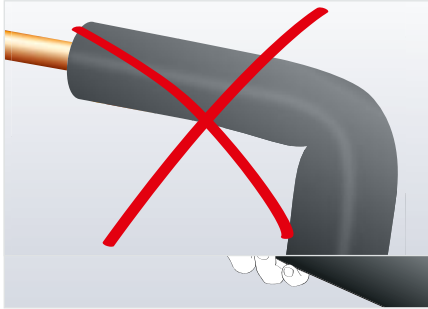

Use sharpened off-cuts of pipes to make holes.

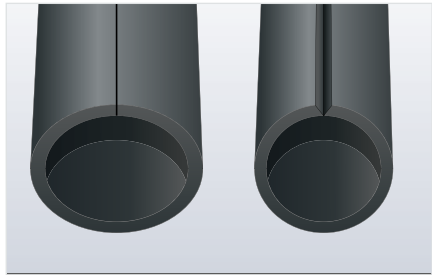
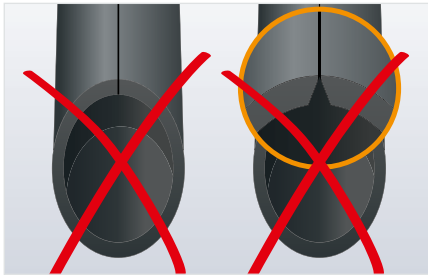

Always cut on the flat sides of tubes.

## INSULATING NEW PIPEWORK USING SLEEVE-ON TECHNIQUE

In principle, tube material can simply be slid round bends. Using rotational movements while pushing, can ease the process.

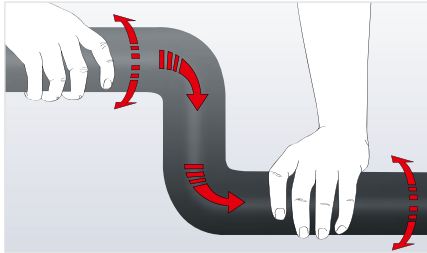

**Note:** Always apply and push the ArmaFlex tube over the pipe as shown, making sure that the longitudinal seam is arranged to the side but neither to the throat nor to the back area.

However, with tight bends (such as those likely to be encountered on small bore pipes) there is a risk that the insulation will kink in the throat of the bend, reducing insulation thickness.



In the refrigeration/air-conditioning sector the calculated insulation thickness is then no longer achieved and condensation can occur on the surface of the insulation. When installing tubes with a self-adhesive seal, there is the additional risk of compression of the adhesive lining in the bend area, which can lead to seams coming apart.

The following should be taken into account in these cases:

If the insulation kinks and the adhesive seam is compressed, the bends should be cut into segments to fit (see “Segment bend with 1 middle part - 2+1 using ArmaFlex tube” on page 25). In such cases we only recommend the use of standard, non self-adhesive, tubes.

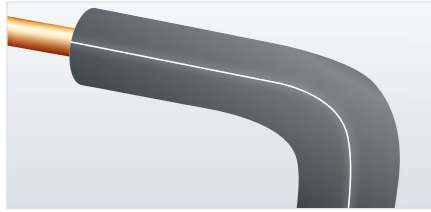
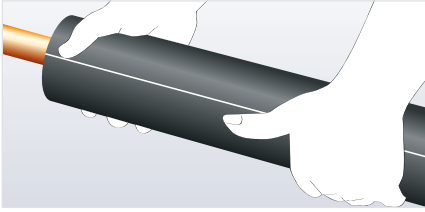

**Note:** Always apply and push the ArmaFlex tube over the pipe as shown, making sure that the longitudinal seam is arranged to the side but neither to the throat nor to the back area.

### INSULATING EXISTING PIPEWORK USING SNAP-ON TECHNIQUE

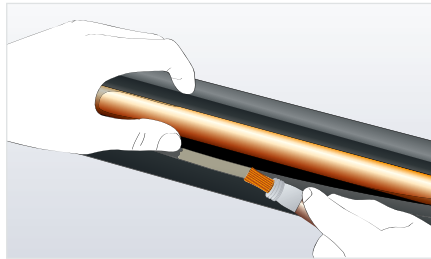
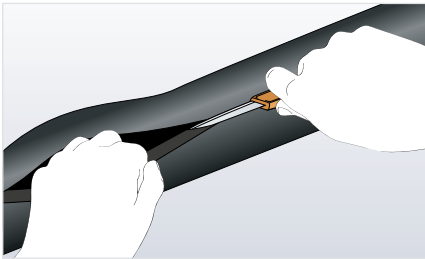

1. With a sharp knife, slit the flat part of the unslit tube along the entire length.
2. Place the slit tube onto the clean pipe; apply a thin, even film of ArmaFlex adhesive to the two cut edges using a short bristle brush. Apply the adhesive along the tube length.

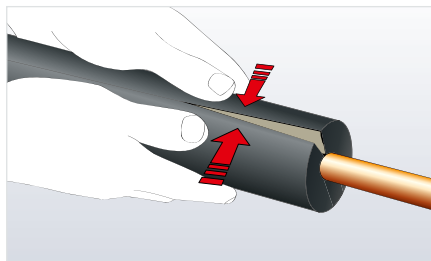
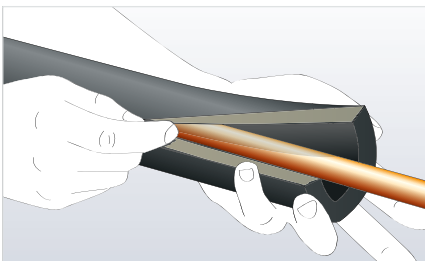

3. Allow the adhesive to touch dry, test with the fingernail.
4. Free the seams from the pipe where applicable, align the edges and press the seam detail with firm, even pressure to finish.

### INSULATING PIPES WITH ARMAFLEX SELF-SEAL TUBES

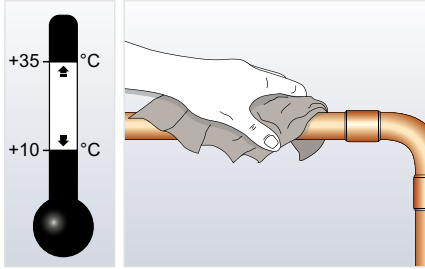

Clean all dust, dirt, oil and water from pipework using ArmaFlex Cleaner where necessary. Install ArmaFlex when ambient temperature is between +10 and +35 °C.

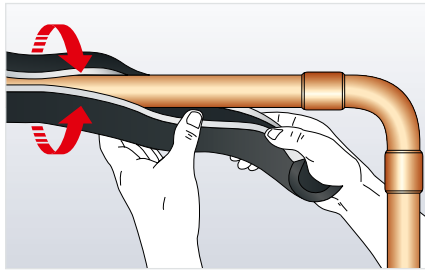

Open pre-slit ArmaFlex and snap onto pipe (the release paper is still protecting the self-adhesive strip)

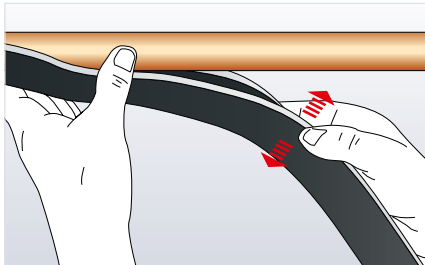

Adjust fitted ArmaFlex to ensure slit is easily accessible.

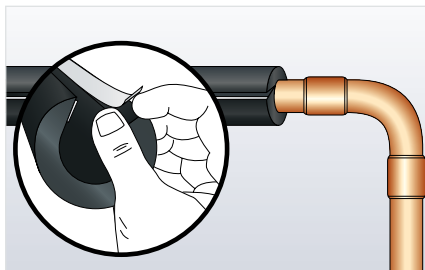

Locate the end of white release paper for the self-seal strip.

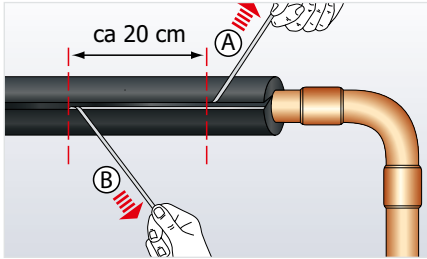

Remove the white protection paper strip on both sides, by drawing it away from the insulation. Please note: remove protective release paper strip from both sides!

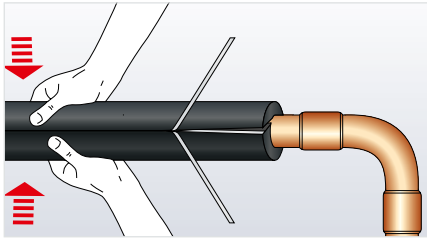

Close the slit seam and press together firmly to ensure a permanent seal.

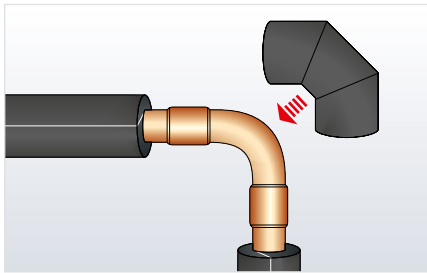

Insulate all other straight pipe sections following the procedure described previously. Finally, insulate all elbows, T-pieces etc. (see "Segment bend with 1 middle part - 2+1 using ArmaFlex tube" on page 25)

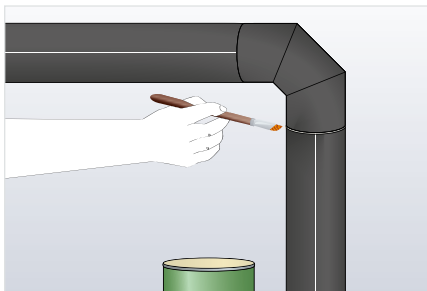

Seal all joints with ArmaFlex adhesive. Do not stretch when sealing joints. When gluing joints under compression, with no gaps present, the wet adhesive method should be applied.

**Important:** For NH/ArmaFlex self-adhesive tubes the same rules apply as for ArmaFlex Ultima self-adhesive tubes (see next pages).

### INSULATING PIPES WITH ARMAFLEX ULTIMA SELF-SEAL TUBES

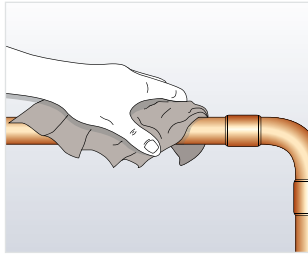
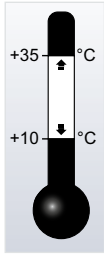

Clean all dust, dirt, oil and water from pipework using ArmaFlex Cleaner where necessary. Install ArmaFlex when ambient temperature is between +10 and +35 °C.

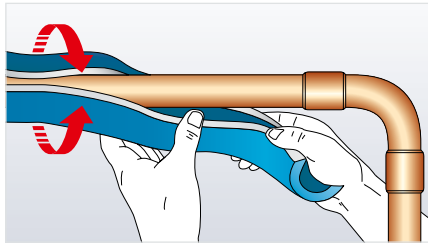

Open pre-slit ArmaFlex and snap onto pipe (the release paper is still protecting the self-adhesive strip)

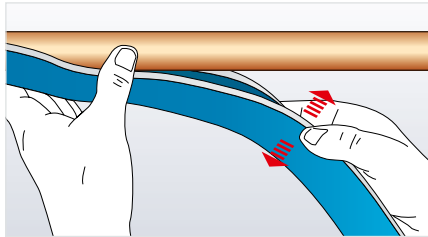

Adjust fitted ArmaFlex to ensure slit is easily accessible.

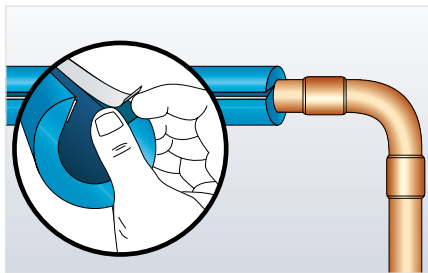

Locate the end of white release paper for the self-seal strip.

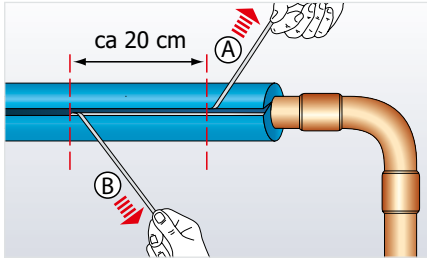

Remove the white protection paper strip on both sides, by drawing it away from the insulation. Please note: remove protective release paper strip from both sides!

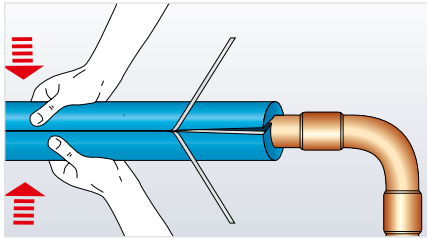

Close the slit seam and press together firmly to ensure a permanent seal.

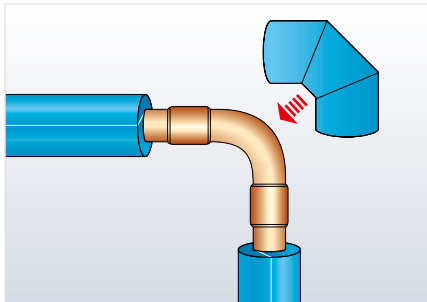

Insulate all other straight pipe sections following the previous described procedure. Finally insulate all elbows, T-pieces etc. (see “Segment bend with 1 middle part - 2+1 using ArmaFlex tube” on page 25)

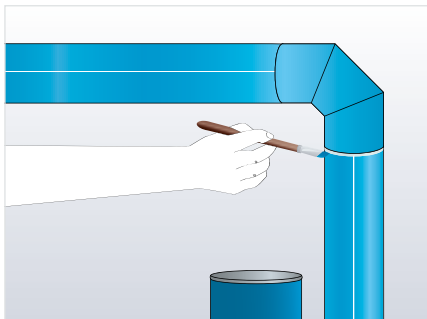

Seal all joints with ArmaFlex Ultima adhesive. Do not stretch when sealing joints. When gluing joints under compression, with no gaps present, the wet adhesive method should be applied.

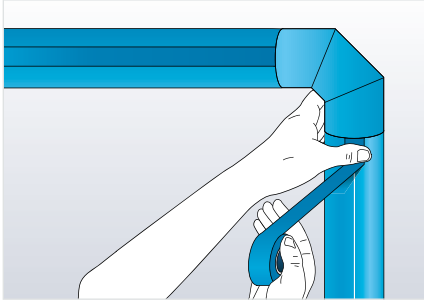

For additional security it is necessary to secure the longitudinal joints of ArmaFlex Ultima self-adhesive tubes with an additional ArmaFlex Ultima self-adhesive tape. Ensure that the surface is clean, dry and free from contamination, if necessary please clean it with ArmaFlex Cleaner.

## MULTI-LAYER INSULATION OF PIPEWORK

### Staggering on pipework: cross-section view



### Multi-layer insulation with tubes

The inner diameter of the second oversize tube should be selected according to the maximum outer diameter of the first layer.

### Staggering on pipework: longitudinal view



yellow lines indicate glued seams

### Multi-layer insulation as a combination of tubes and sheets

If the outer diameter of the first layer is large enough (see “Insulating pipes with ArmaFlex sheet” on page 29), we recommend that the second layer is made with sheet material, since this can be adapted exactly to the outer diameter of the first layer.

### Multi-layer insulation of pipework with sheets

In general the insulation of pipes with sheet material is possible at an outer diameter of 89 mm. Select layer insulation thickness combinations as appropriate depending on the outer diameter of the object (see “Insulating pipes with ArmaFlex sheet” on page 29).

**Note:** The ends of the tube or sheet of the second layer should be adhered to the first layer of ArmaFlex. If there is a risk of the insulation on the underside of the pipe sagging, it should be fully adhered to the underlying layer. When the piping diameter is above 600 mm, all-over adhesive coverage is necessary on both surfaces.

To prevent corrosion under the insulation (CUI), all-over adhesive coverage is recommended.

### Multi-layer insulation of flat surfaces with sheets

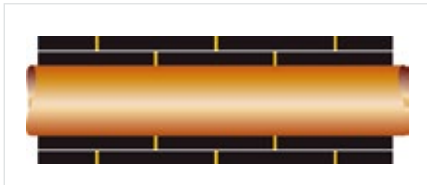

Yellow lines indicate glued seams

In the case of multi-layer insulation, the first layer should be applied using all-over adhesive coverage. The second layer should be adhered to the previous layer of ArmaFlex. Insulation on the underside of flat objects should be applied using all-over adhesive coverage for all

layers. In general the butt joints and the longitudinal seams of the second layer should be staggered to those of the first layer.

## USING THE ARMAFLEX TEMPLATE

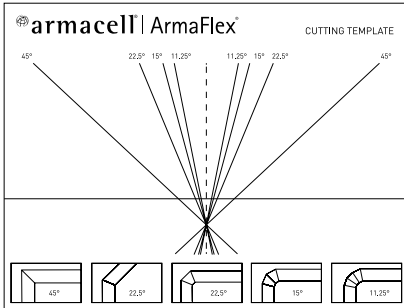

### BEND WITH 90° ANGLE USING ARMAFLEX TUBE

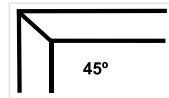
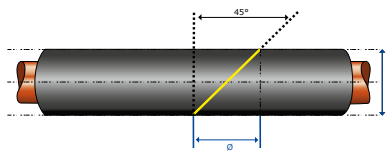

### BEND WITH 45° ANGLE USING ARMAFLEX TUBE

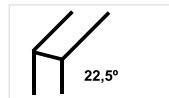
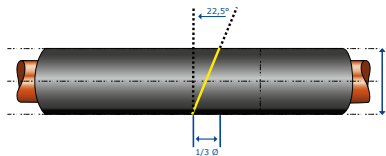

### SEGMENT BEND WITH 1 MIDDLE PART - 2+1 USING ARMAFLEX TUBE

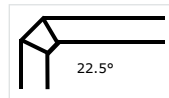
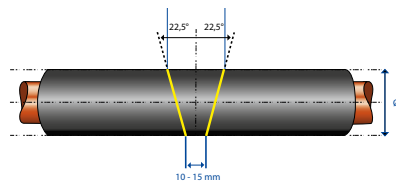

### SEGMENT BEND WITH 2 MIDDLE PART - 2+2 USING ARMAFLEX TUBE

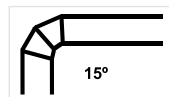
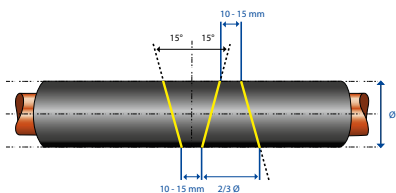

## SEGMENT BEND WITH 3 MIDDLE PARTS - 2+3 USING ARMAFLEX TUBE

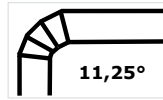
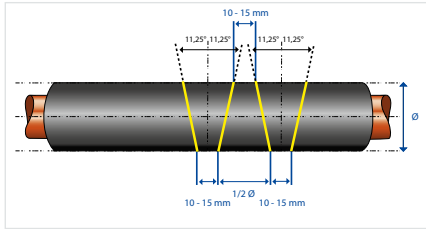

## T-PIECE USING ARMAFLEX TUBE

### The “Punched Hole” T Piece

**Note:** Yellow lines indicate where cuts are to be made.

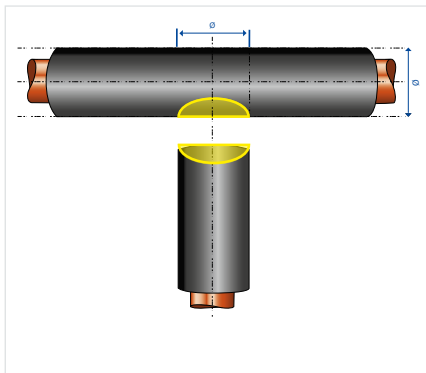

1. Punch a hole in the tube with a sharpened section of a copper pipe of the right diameter, forming the crossbar of the “T”.

**Note:** For larger hole cut-outs use a pair of dividers to “mark out” and cut using a small sharp knife.

2. Slit this section of the tube open (half through the hole) and slide it over the pipe.

3. Cut a semi-circular recess in the end of the branch section of tube. It is better to have a cut which is a little too deep rather than too shallow.

4. Attach the branch section to the pipe and join the two halves of the “T”. Adhere all seams with ArmaFlex adhesive.



To the videos

## Insulating coupling pipe joints

### METHOD 1: OVERSIZED 90° BEND

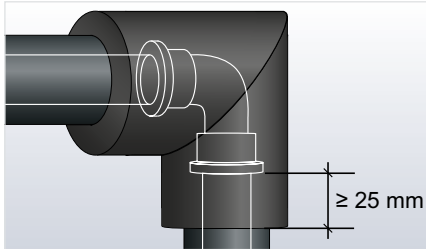

Insulate up to the pipe fitting using ArmaFlex tube and secure to the pipe using adhesive

1. The fitting cover is made from tube the bore od which is the O.D. of the incoming tube. Provide a minimum overlap of 25 mm on each side (increase the distance of the overlap to match the insulation wall thickness if this exceeds 25 mm). The fitting may be made up using any of the methods described on page (see "Bend with 90° angle using ArmaFlex tube" on page 24).
2. Slit in the throat, apply adhesive to seams, fit when tack dry. Wet seal overlaps.

### METHOD 2: SMOOTH FINISH 90° BEND

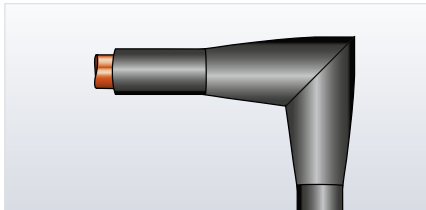

1. The fitting cover is made from tube material, the inner diameter of which corresponds to the maximum outer diameter of the screwed fitting. Provide at least a 40 mm overlap beyond the end of the fitting on each side.
2. For pipes up to 35 mm, cut two wedge-shaped pieces at 180° to each other, from top and bottom centres, at each end of the fitting. For large inner diameter tubes cut four wedges, one at each 90° around the circumference. The wedges should taper back to the points where the fitting would start and be sized so that the inner diameter of the ArmaFlex reduces to the outer diameter of the incoming pipe. Glue the seams on the reducing sections.
3. Slit in the throat, apply adhesive, allow to tack dry, then fit. To complete, wet seal butt joints with ArmaFlex adhesive.

## Angle T-piece (off-set) using ArmaFlex tube

### METHOD 1

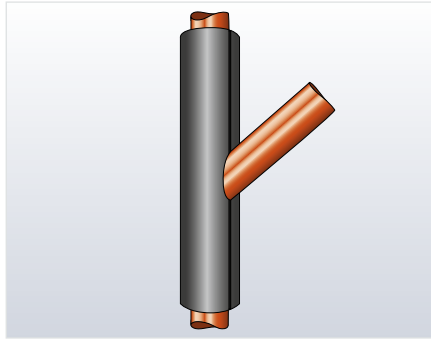
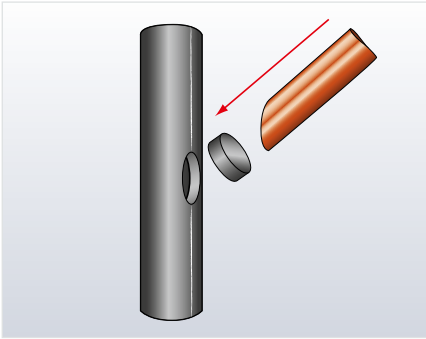

1. Using a sharpened section of copper pipe of the correct diameter, punch a hole in the tube used to cover the main pipe. Make sure that the angle corresponds to that of the branch pipe.

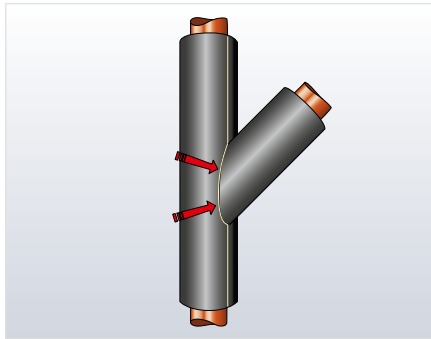
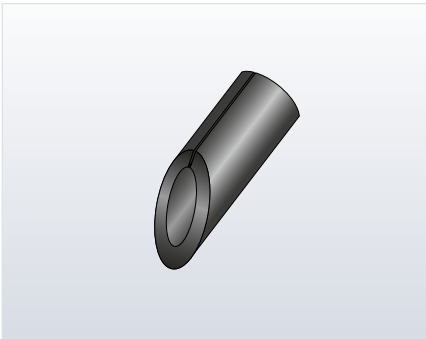

2. Cut a 45° angle at the end of the tube sections for the branch pipe. Parallel to the cut, use a sharpened knife to cut a semi-circular recess in the end of the branch section of tube. It is better to have a cut which is slightly too deep rather than slightly too shallow.
3. Glue both pieces together using ArmaFlex adhesive.
4. Slit the shaped piece, apply adhesive to seams and fit when tack dry.

## Pipe reducer using ArmaFlex tube

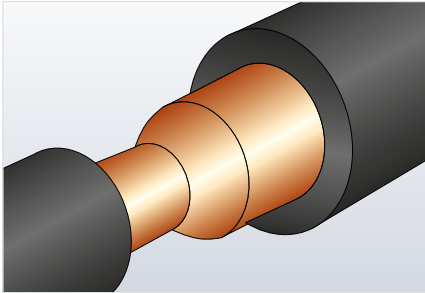

Pipe reducer to be insulated

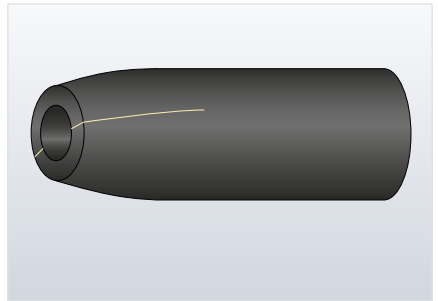
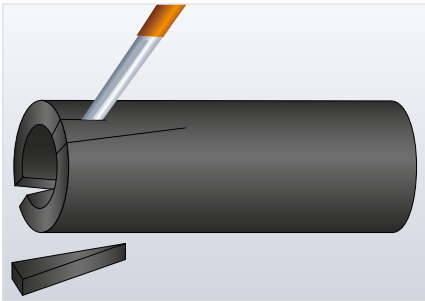

Cut out segments from a tube of the larger diameter and glue seams with ArmaFlex adhesive.

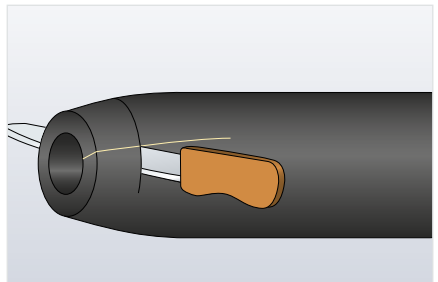
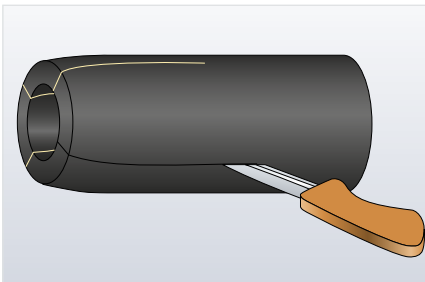

Cut reducer to size - allow compression of 5 mm at each end. Slit fitting on the flat side.

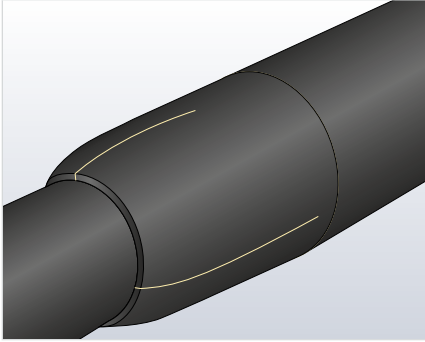

To the video



Install and glue seam and butt joints.

## Insulating pipes with ArmaFlex sheet

AF/ArmaFlex, AF/ArmaFlex Evo tubes are available for pipes with outer diameters up to 168 mm, ArmaFlex Ultima, HT/ArmaFlex, NH/ArmaFlex and NH/ArmaFlex Smart tubes are available for pipe with outer diameters up to 89 mm. Larger pipes and ducts as well as tanks should be insulated with ArmaFlex sheet, and all-over adhesive surface coverage is required for pipes with an outer diameter above 600 mm.

It is often advantageous to insulate smaller pipes using ArmaFlex sheet, even when correctly dimensioned tubes are available. Care should be taken to ensure that the stresses in the seams, caused by the bending in the sheet, do not become too great.

These stresses rise as the insulation thickness increases and as the pipe diameter decreases. Please consult the table below to gauge the applicability of different thicknesses of ArmaFlex sheet (recommendations may vary for HT/ArmaFlex and NH/ArmaFlex).

The ambient temperature during installation will also impact on the levels of stress likely to be encountered.

For advice on installing ArmaFlex sheet in ambient temperatures  $\geq 5\text{ }^{\circ}\text{C}$  please see following table.

AF/ArmaFlex Sheets	Pipe Outer Diameter / mm				
	≥ 88.9	≥ 114	≥ 139	≥ 159	≥ 408
AF-10-MM	●	●	●	●	●
AF-13MM	●	●	●	●	●
AF-16MM	●	●	●	●	●
AF-19MM	●	●	●	●	●
AF-25MM		●	●	●	●
AF-32MM			●	●	●
AF-50MM					●

**Note:** AF/ArmaFlex tubes are offered with engineered wall thicknesses. This should be taken into account when selecting AF/ArmaFlex sheet thicknesses.

HT/ArmaFlex* NH/ArmaFlex NH/ArmaFlex Smart ArmaFlex Ultima** AF/ArmaFlex Evo	Pipe Outer Diameter / mm			
	≥ 88.9	≥ 114	≥ 139	≥ 159
6 mm	●	●	●	●
10 mm	●	●	●	●
13 mm	●	●	●	●
19 mm	●	●	●	●
25 mm			●	●
32 mm				●

\* HT/ArmaFlex sheets are not available in 6 mm and 32 mm thickness

\*\* ArmaFlex Ultima sheets are not available in 32 mm thickness

## Insulating large pipes with ArmaFlex sheet

1. Determine the circumference of the pipe.  
**Important:** Always measure with a strip of ArmaFlex of the thickness to be used for the insulation.

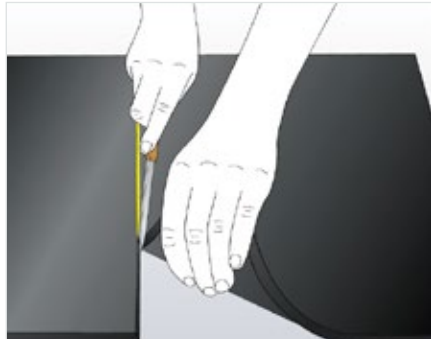
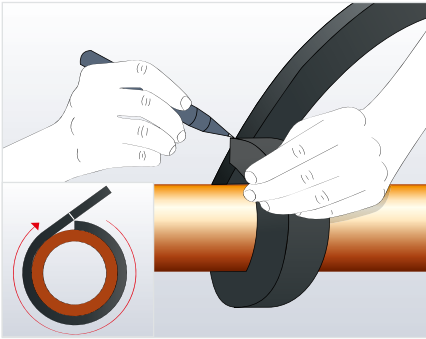

**Warning:** Do not stretch the strip.

2. Cut ArmaFlex sheet to the required size - apply ArmaFlex adhesive to the cut surfaces in a thin layer, allow to tack dry.
3. Press together at the ends and then in the middle. Close the entire seam starting from the middle.

**Note:** In order to prevent the seam re-opening, ensure the adhesive has been fully applied to the edges of the seam and ensure the correct amount of adhesive has been applied.

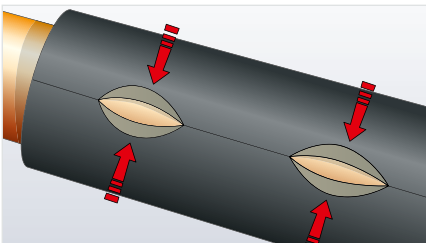

Check the open time of the adhesive to ensure it is still fit for use.

## Two-part bend with ArmaFlex sheet

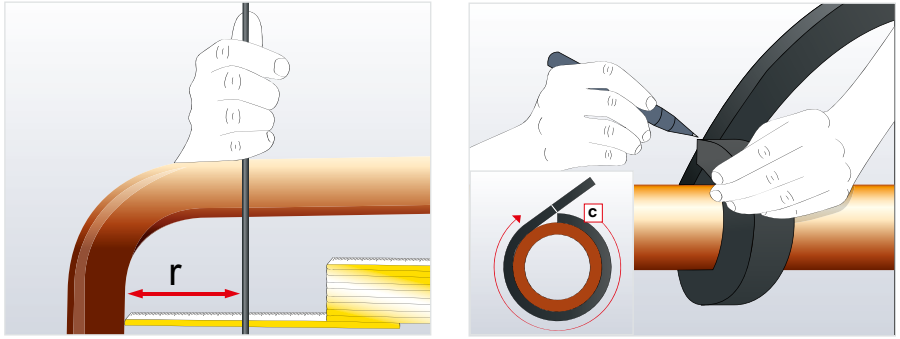

Establish the inside radius, "r", by dropping a perpendicular line to meet a horizontal line from the outside of the two welds. The point where these two lines intersect gives the origin for the radius, r. This is the throat radius.

Measure in a trimming allowance (determined by the insulation thickness) along both vertical and horizontal edges then transfer to the sheet as indicated.

Determine the circumference of the pipe using a strip of ArmaFlex of the thickness to be installed

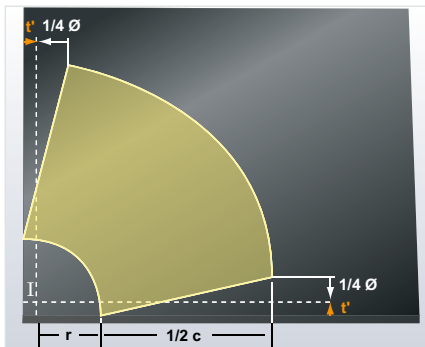

Halve the pipe circumference and transfer this dimension to the ArmaFlex sheet.

Mark out the two arcs from the intersection of the trim lines.

$r$  = inside radius of bend

$\frac{1}{2} c$  = half of pipe circumference

$I$  = intersection point

$t'$  = insulation thickness (in mm)

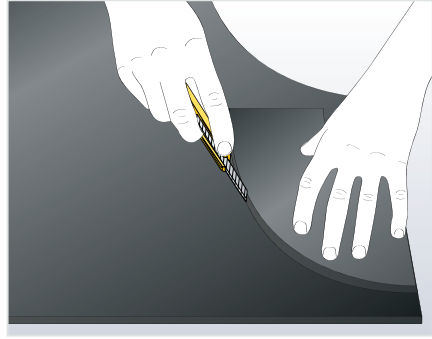
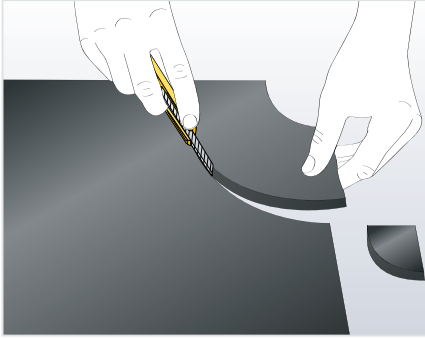

Cut out the first half-section of the elbow.

Use the first half-section as a template to cut out the second half-section of the elbow.

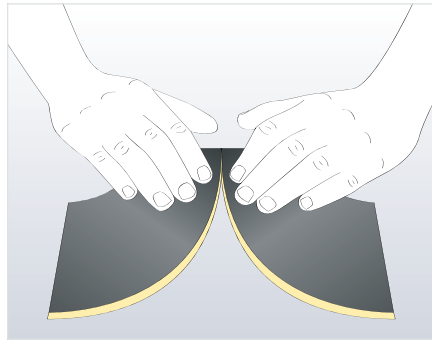
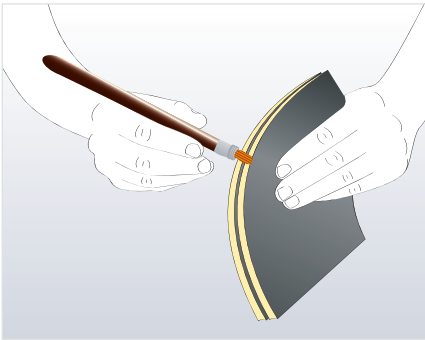

Place the sections together with the rough surfaces inwards. Apply ArmaFlex adhesive to the outer edges.

Allow the adhesive to tack dry (fingernail test) then press the two sections together at one side to make a short seam.

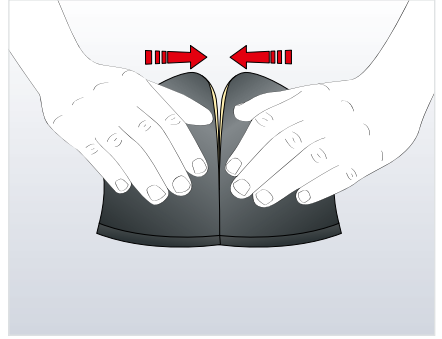
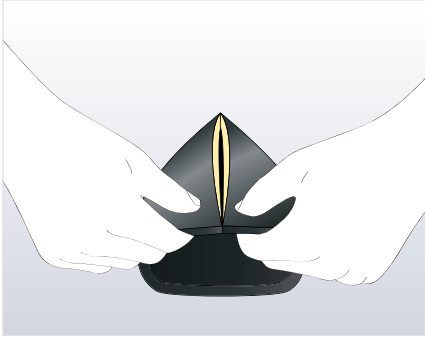

Next, press the opposite sides together, also making a short seam. Working towards the centre.

Press the remainder of the joint firmly together.

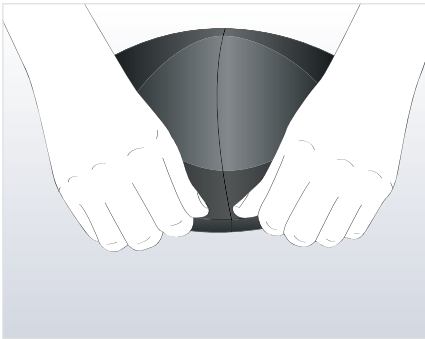

Turn the assembly over and press the seam firmly together from the inside, so that a good adhesive joint is achieved across the entire wall thickness.

Apply ArmaFlex adhesive to the inner joint edges.



To the video

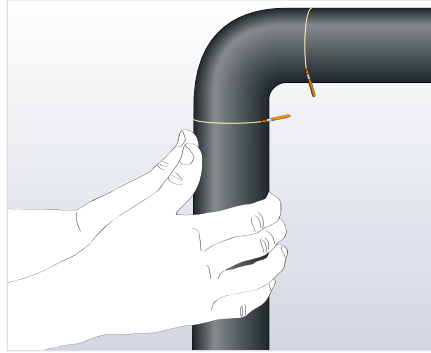
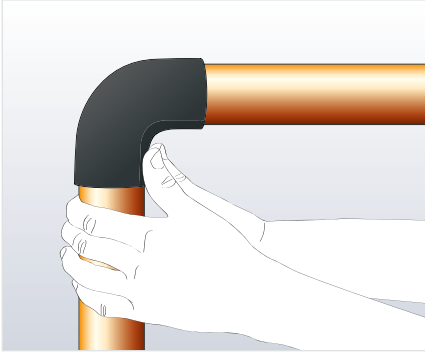

Place the insulation cover over the pipe bend. Allow the adhesive to tack dry, then press the joint faces firmly together.

Wet seal jointing details with adhesive, fitted under slight compression, to complete the bend.

### Valve insulation with ArmaFlex sheet

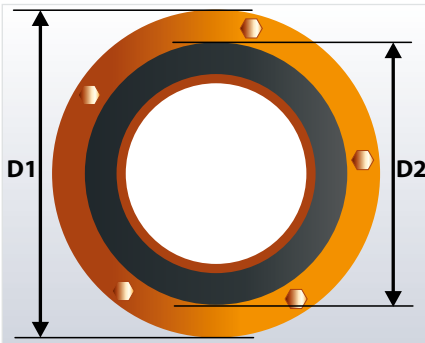

For greater stability, the valve body can be strengthened by covering with a pre-cut metal or plastic part.

Insulate the pipe up to the flange.

Determine

D1 = depth of flange ring

D2 = circumference of insulated pipe

Fabricate two end discs:

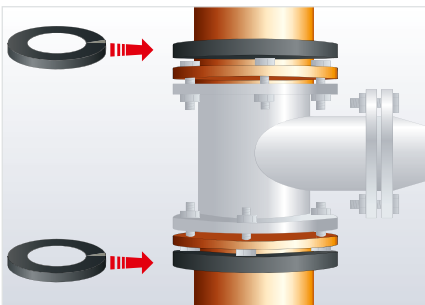

With the corresponding radius of D1 mark a circle on ArmaFlex sheet material, with the radius D2 mark the cutout. First cut out the whole disc, then the cutout. Cut the discs on one side and glue together again on the insulated pipe.

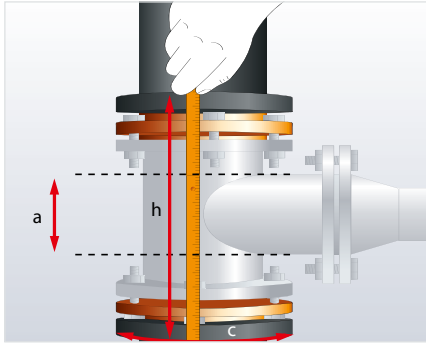

Fabricate the valve body

Measure

$h$  = height between the outer faces of the two rings.

$a$  = diameter of spindle neck

$c$  = circumference of the rings

**Important:** Always measure with a strip of ArmaFlex of the thickness to be used for the insulation. Do not stretch the strip.

Transfer height ( $h$ ), circumference ( $c$ ) and diameter of spindle neck ( $a$ ) to the ArmaFlex sheet and mark the cutouts for the spindle neck.

**Note:** Cutouts should always be made 5 mm less than measured.

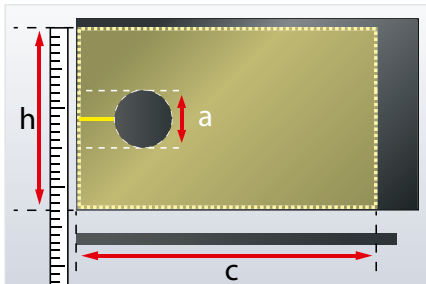

**Note:** For valve spindles without connecting flanges it is recommended that the cutouts are marked in the first quarter of the ArmaFlex sheet.

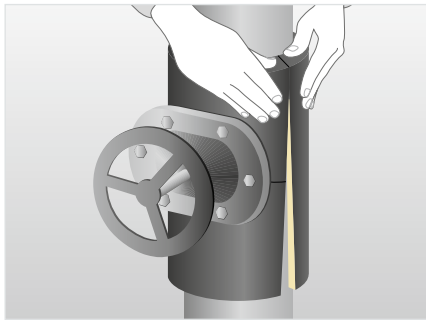

Cut the valve jacket and fit on the valve. Then apply a thin coat of ArmaFlex adhesive to all seams of the valve cover. Allow to tack dry (fingernail test), fit, then press together firmly.

**Note:** The valve body should always be insulated after the pipe.

To increase the security of the seams, pre-fabrication of the valve cover on the workbench is recommended based on accurate measurements.

## Insulating neck-T / pipe-T / spindle neck of valve with ArmaFlex sheet

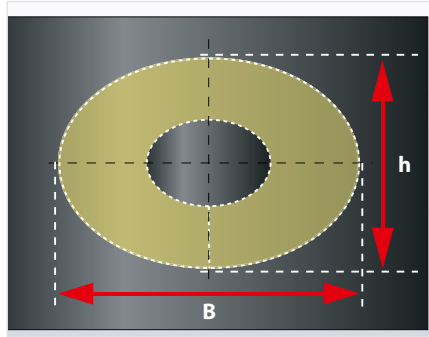
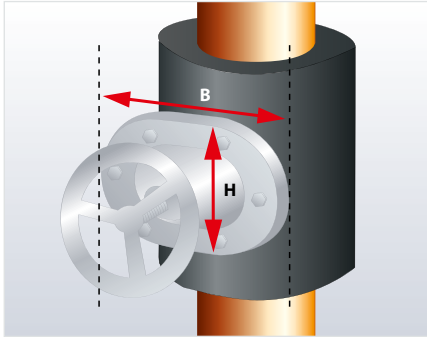

Measure the height of the spindle housing flange and its width, and fabricate an end disc.

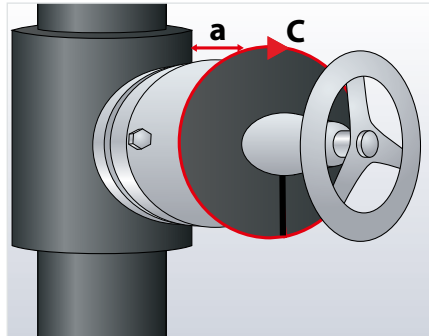
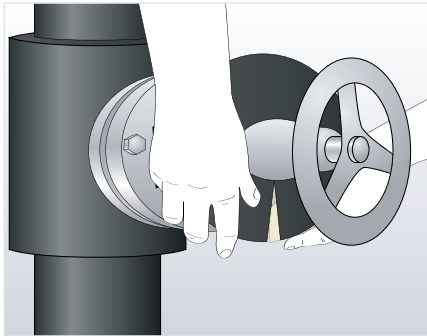

Cut through the disc on one side, apply adhesive to the cut edges, allow to tack dry. Re-join the end disc after placing it over the spindle neck. Measure the circumference of the end disc with a strip of ArmaFlex and transfer the measurement to the sheet material.

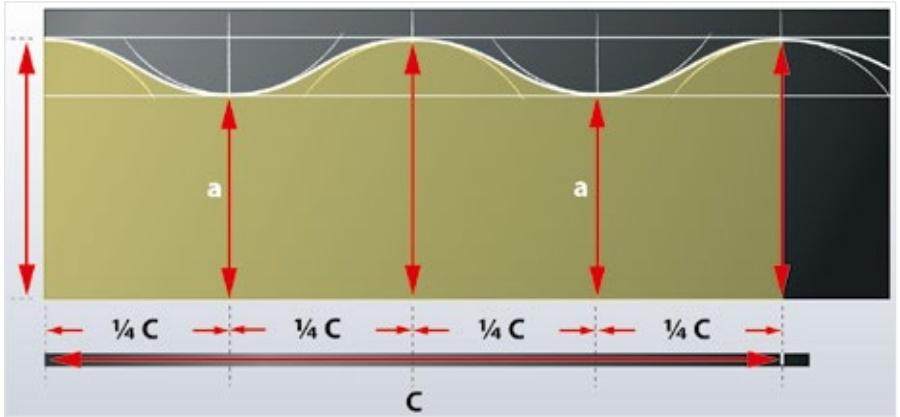

Dividing the circumference into four equal parts has resulted in five lines. Set the dividers to the radius of the insulated valve body and draw two circles at the top end point of each of the distances  $a$  (The second and fourth lines from the left.)

Using the same radius and starting from lines 1, 3 and 5, determine the tangential points of the first two circles by drawing three arcs.

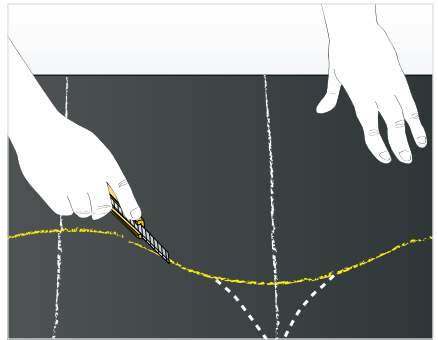
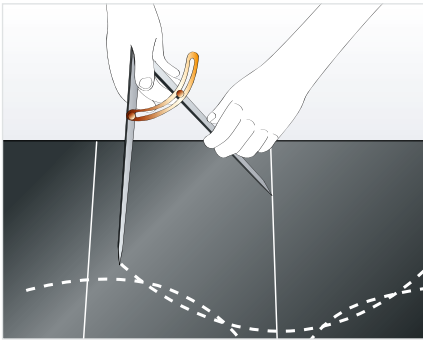

The resulting line above the tangential points of the five circles marks where the sheet rests against the side of the valve body. Cut the cover out along this line.

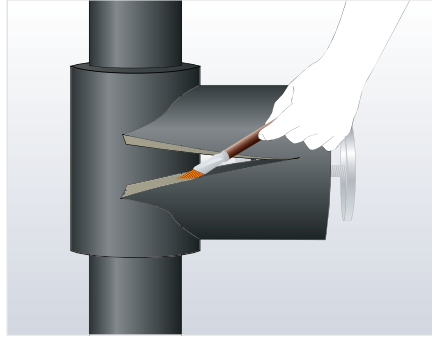
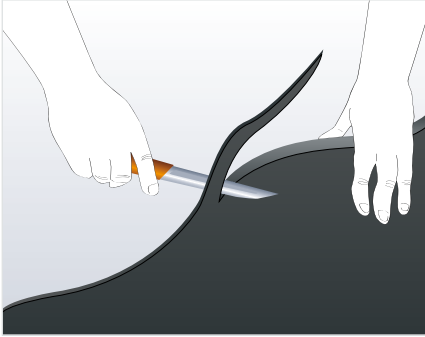

Chamfer away the inside surface at the highest point (where the sheet rests against the side of the valve body).  
Apply adhesive to the longitudinal seam, allow to tack dry, then seal round the spindle housing.

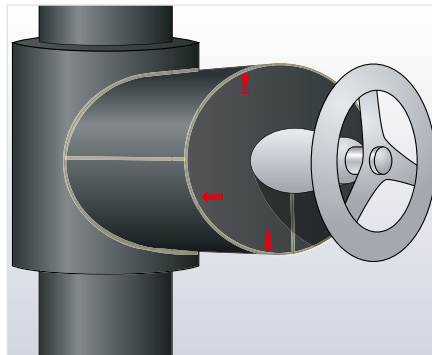
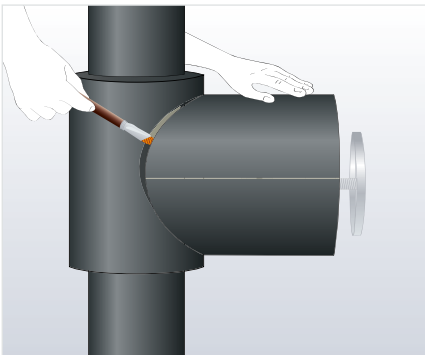

**Important:** Secure bonding in the area of the spindle neck penetration is essential.

**Note:** ArmaFlex tape may be applied to the spindle neck in the area of the penetration to provide additional protection.



To the video

## Insulating valves with D-box made of ArmaFlex sheet

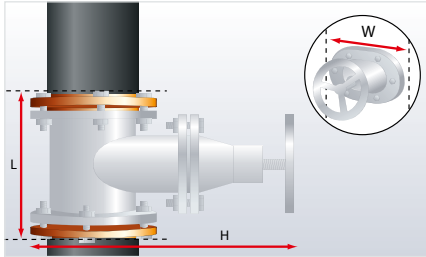

Establish the following measurements:

$L$  = length of valve + 2 x thickness of insulation

$H$  = height of valve + 2 x thickness of insulation

$W = \text{Ø (diameter)} + 10\text{mm}$

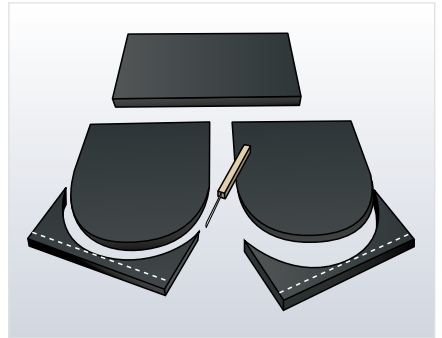
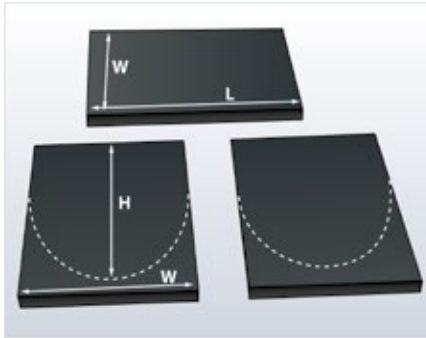

Mark out and fabricate 2 end panels and 1 top panel using the measurements taken in the previous step.  
Cut cleanly using a small sharp knife.

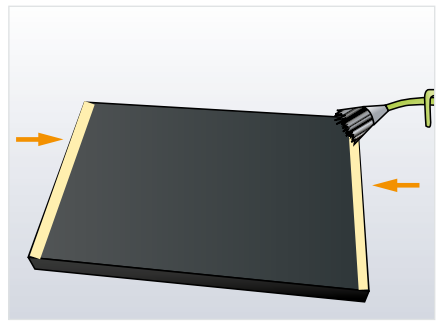
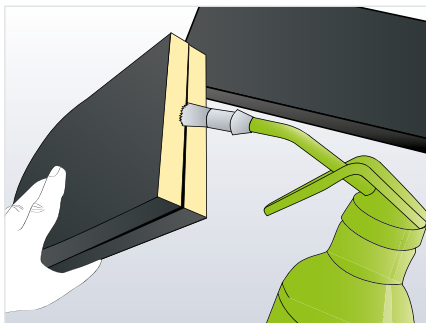

Apply ArmaFlex adhesive along the edges as indicated.

**Note:** The glue line must be as wide as the thickness of the ArmaFlex used.

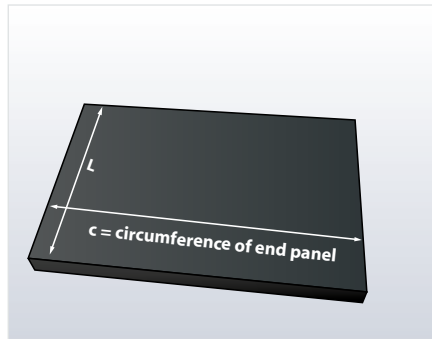
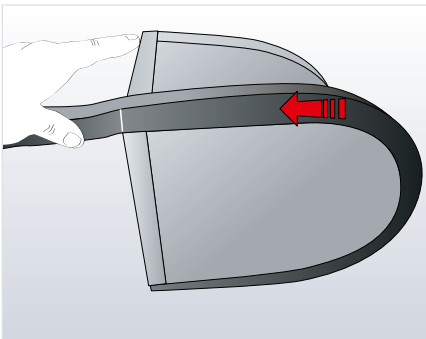
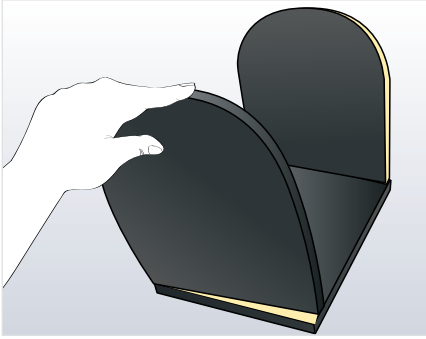

Glue the top edges of the end panels and the top panel edge.

Secure the end panels to the top panel making sure the edges are aligned.

Use a strip of ArmaFlex (used thickness) to determine the circumference around one end panel (including the top panel).

Mark measurement L and circumference and cut the body panel to size.

Apply ArmaFlex adhesive to the body panel end and the body panel edges as shown.

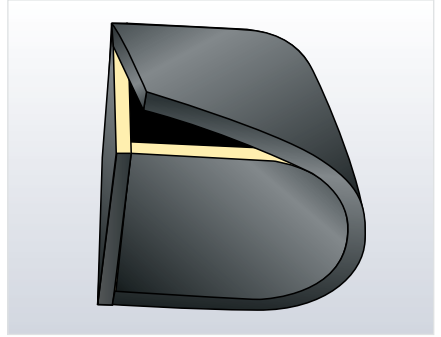
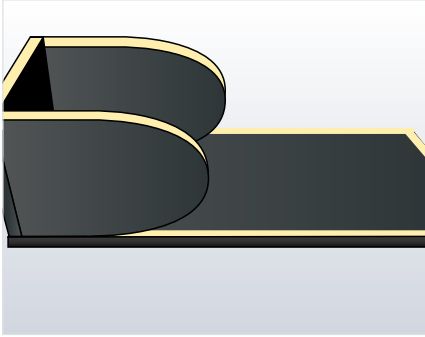

Gently roll the body panel edges around the end panels until the cover panel resembles a box.

Fix down the square 90° edge as shown. Ensure the edge is aligned and neat. Continue to secure all edges in this way.

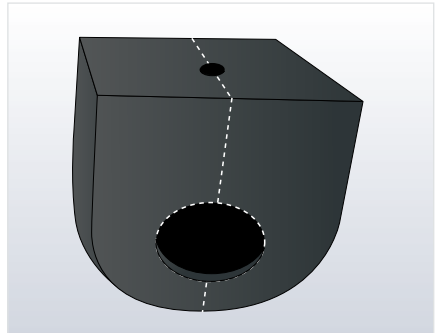
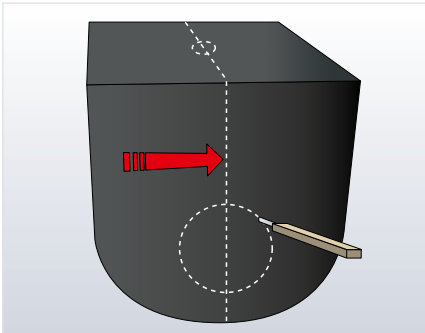

Cut holes for the insulated piping connections on each of the end panels and a final cutout for the valve spindle connection at the top. Split the box into two halves and fit around the valve. To finish, apply ArmaFlex adhesive to the seams, allow to tack dry and join the seams.

Vapour seal the connections (joints) to the linear insulated pipes using ArmaFlex adhesive.

**Important:** Secure bonding in the area of the spindle neck penetration is essential.

**Note:** ArmaFlex tape may be applied to the spindle neck in the area of the penetration to provide additional protection.

## Offset angle & pipework bend angle joints

The following illustrations show the various stages of work when insulating a mitre angle or bevel joint in a pipe. The procedure when insulating a right angle pipe joint is effectively the same.

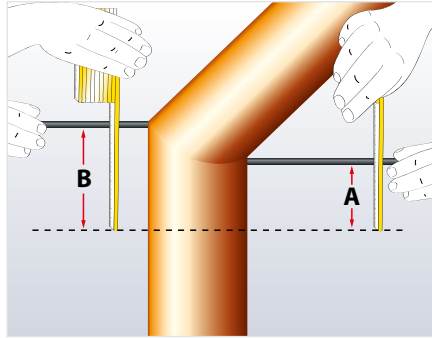
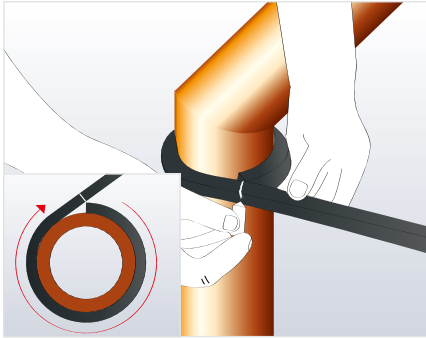

Determine the circumference of the pipe (C)

**Important:** Always measure with a strip of ArmaFlex of the thickness to be used for the insulation. Do not stretch the strip.

Measure the outer height (B) and the inner height (A) of the mitre joint.

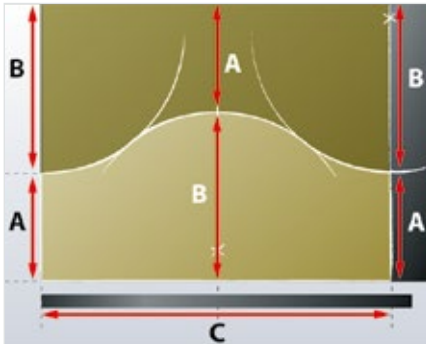

Transfer the circumference to the ArmaFlex sheet and mark the centre line.

Transfer the outer and inner height to the ArmaFlex sheet.

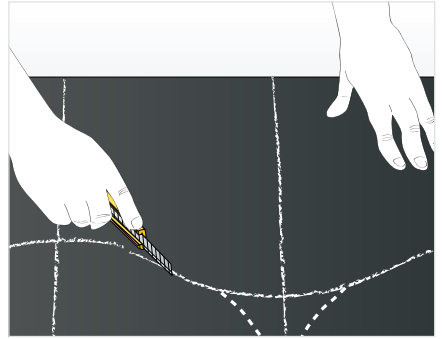
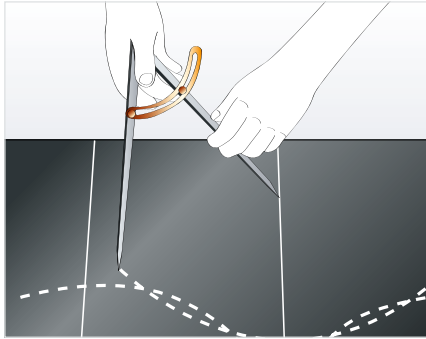

Using the radius of the pipe circumference draw an arc from the centre line and the opposite corners. The circles must only touch at one point (the tangential point). Cut out the fitting cover along the marking. When offset by 180° the top and bottom part form the two matching parts of the bevel joint.

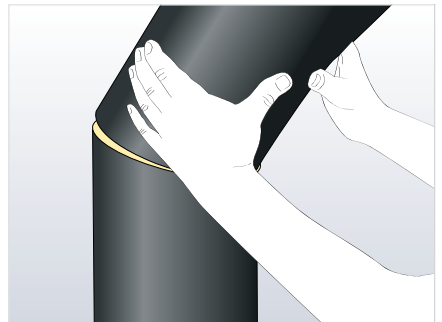
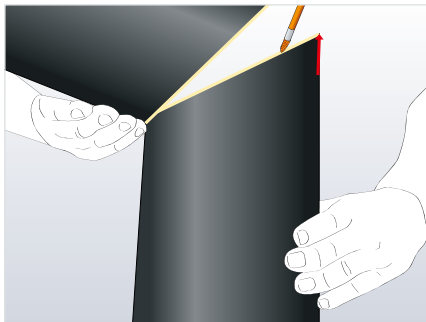

Apply ArmaFlex adhesive to the longitudinal seam, then to the connecting seam.

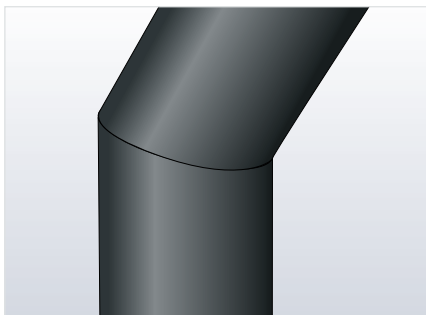

The insulation is now complete.

To the video



## Strainers, strainer valves & inclined seat valves

The work involved in insulating a strainer valve or an inclined seat valve is similar (some measurements need to be extended) except that an end disc may be required.

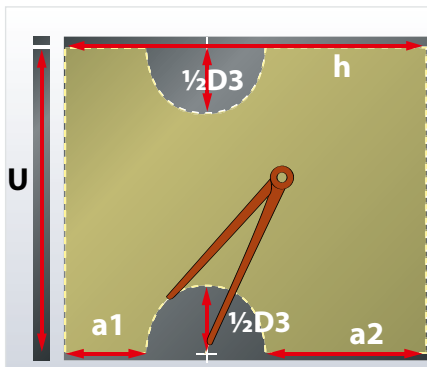
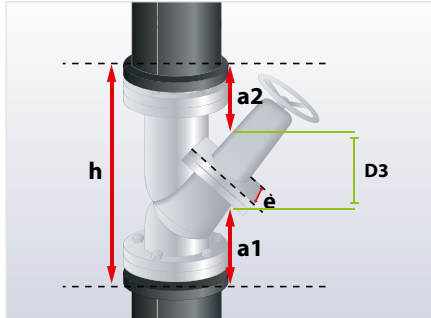
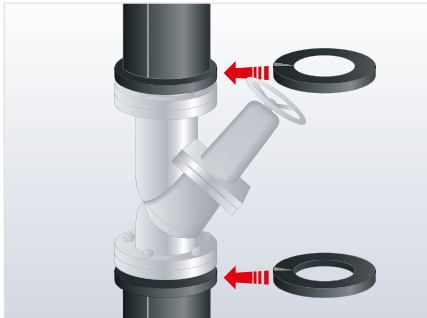
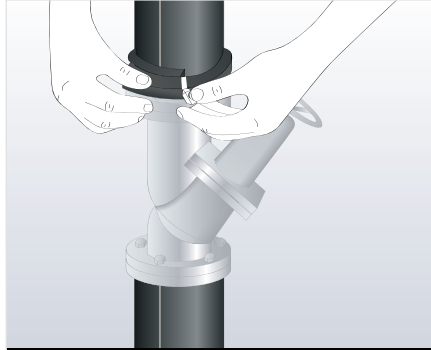
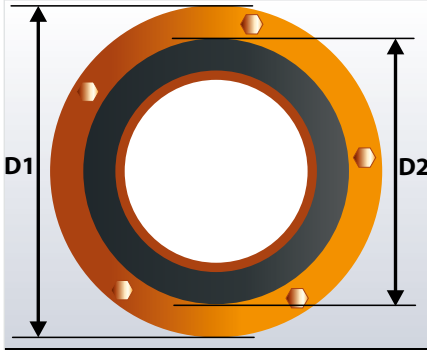

Insulate the pipe up to flange.

Determine

D1 = diameter of the flange ring

D2 = diameter of the insulated pipe

h = distance between the outer surfaces of the two ArmaFlex strips applied to the flanges or the end discs

U = circumference of the ArmaFlex strip or the end disc

a1 = distance from the lower flange to the spindle neck

a2 = distance from flange to spindle neck

D3 = diameter of the spindle neck

e = diameter of the strainer

With the radii of D1 and D2 transfer arcs to the ArmaFlex sheet, thus drawing two end discs. Cut the end discs out then cut them open on one side. Apply ArmaFlex adhesive to the ends of the end discs and glue together over the flanges.

**Note:** If the flange has the same diameter as the insulated pipe, it is not necessary to fabricate end discs. In this case, use a strip of ArmaFlex to double up on the pipe insulation towards the flange. Apply the ArmaFlex strip with the foamed skin upwards.

Next transfer the dimensions U, h, a1, a2 and D3 to a sheet of ArmaFlex and cut out the valve body.

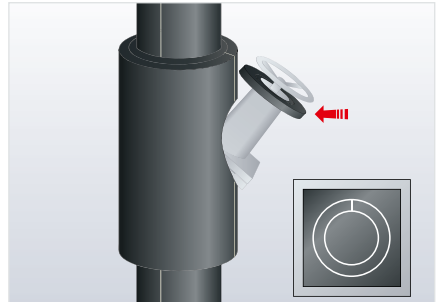
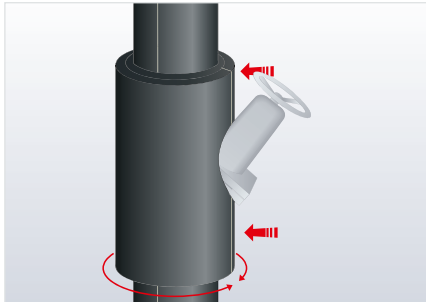

Apply a thin coat of ArmaFlex adhesive to the longitudinal seam, allow to tack dry, place the fitting cover around the valve body and press the seams together.

Then fabricate an ArmaFlex end disc whose an outer diameter is at least equal to the diameter of the valve housing and whose inner diameter is equal to the valve housing (valve spindle).

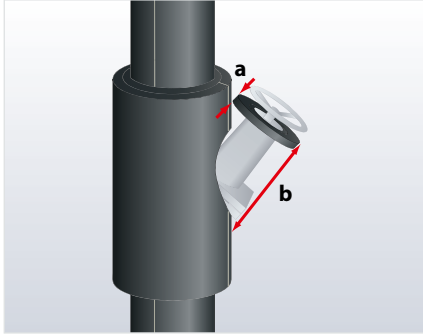

Determine

a = shortest distance between the Armaflex end disc and the insulated valve body

B = greatest distance between the Armaflex end disc and the insulated valve body

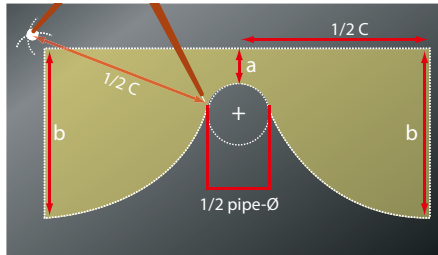
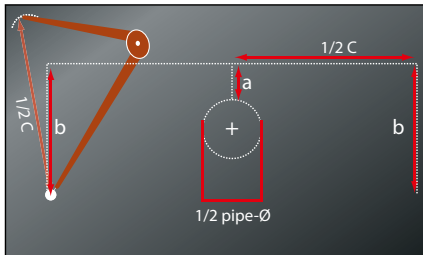

Determine the circumference of the end disc using a strip of ArmaFlex and cut out the ArmaFlex sheet accordingly. Draw in the centre line.

Mark the distance B on the outer boundary line and the distance a on the centre line. Determine the diameter of the insulated valve body. Draw an arc through the end point a with a quarter of this diameter.

Now position the dividers in such a way that an arc is drawn between point B and the circle tangent. (Set the radius of dividers at half of the circumference.)

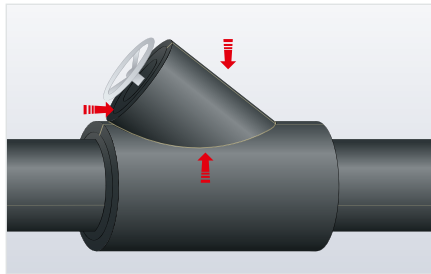
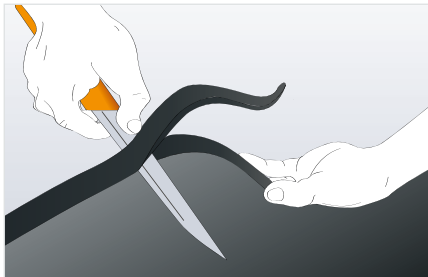

Cut the remaining section of sheet. Chamfer the sheet away where it is to touch the insulation around the strainer body. Apply a thin coat of ArmaFlex adhesive to the longitudinal seam and allow to tack dry. Sleeve the fitting cover over the spindle wheel and glue the pieces together tightly.

## Flange boxes

The following section shows the installation techniques for insulating flanges.

In chilled-water or refrigeration applications it is advisable to pack the gaps between the nuts with strips of ArmaFlex insulation.

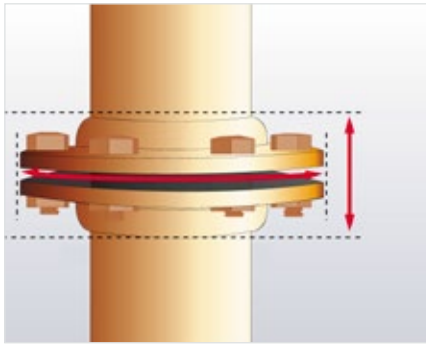

Using a pair of callipers, determine the diameter of the flange face. Add 10 mm to this measurement. Measure the length of the flange (incl. bolts) and add 2x the insulation thickness of the sheet used.

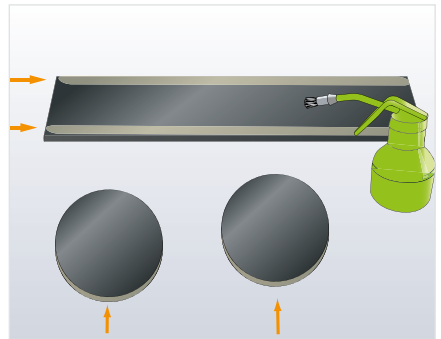
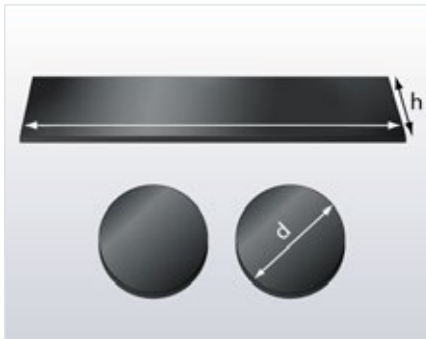

Transfer these measurements to a piece of ArmaFlex sheet. Mark two concentric circles with dividers. Repeat on a second piece of sheet. Cut out two ArmaFlex rings.

Determine the circumference of the disc.

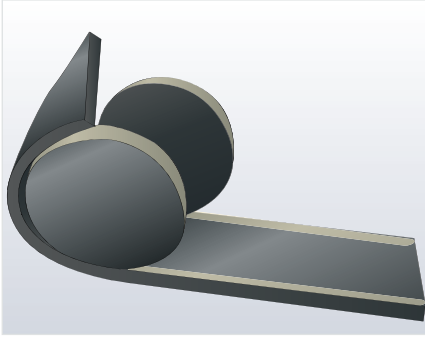

Roll the body panel up and around the end discs, do not stretch during application. Check alignment throughout.

Place the edge to the edge of the adjoining seam opposite.

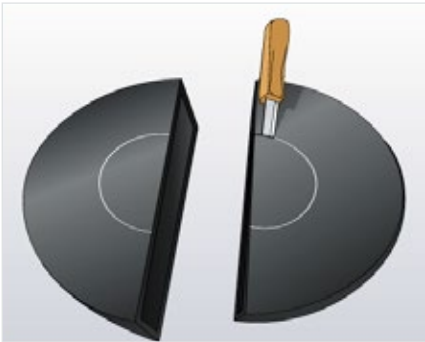

Using a small sharp knife cut out for the insulated pipe diameter.

To finish fit the two halves of the flange box around the flange and wet seal all seams and joints to the insulated pipe branch.



To the video

## Concentric reducers

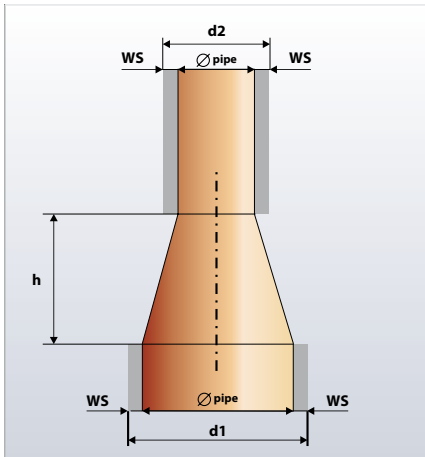

Determine the following measurements

$h$  = height of the reducer, including both welds

$d_1$  = diameter of larger pipe + 2 x insulation thickness

$d_2$  = diameter of smaller pipe + 2 x insulation thickness

Determine the circumferences by placing a strip of ArmaFlex sheet material in the thickness to be used round the larger diameter pipe. Do not stretch the strip.

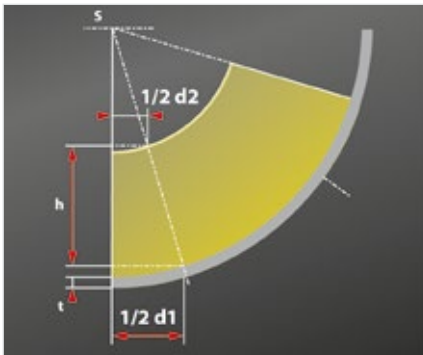

### Thickness of ArmaFlex sheet material

t	6 mm	10 mm	13 mm	16 mm	19 mm	25 mm	32 mm	50 mm
---	------	-------	-------	-------	-------	-------	-------	-------

Transfer the measurements determined onto the surface of the ArmaFlex sheet marked as shown in the picture. Minimise material waste by drawing the half-elevation on the edge of the ArmaFlex sheet.

Draw two arcs guided by the height ( $h$ ) around the  $S$  point. Mark the measured circumference on the larger arc. Draw a line connecting the point marked for the circumference with the  $S$  point.

Cut out the reducer piece with a sharp knife (yellow area indicates the cutting lines).

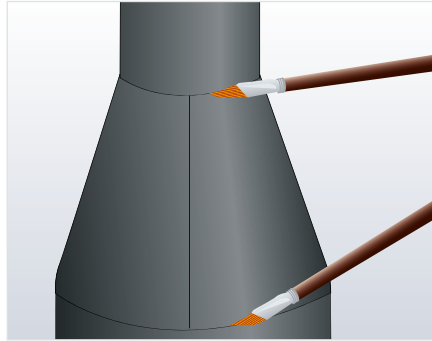
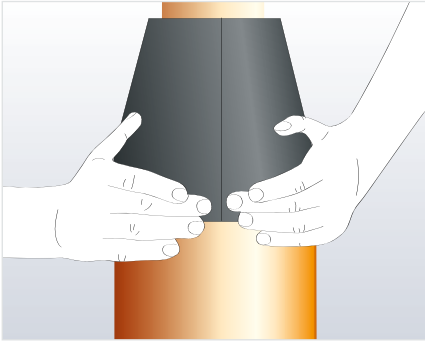

Apply a thin coat of adhesive to the edges to be joined, allow to tack dry. Press together firmly at one end, then at the other end and complete the joint.

Complete insulation by insulating the pipes on either side of the reducer and wet seal both butt joints.

## Excentric Reducer

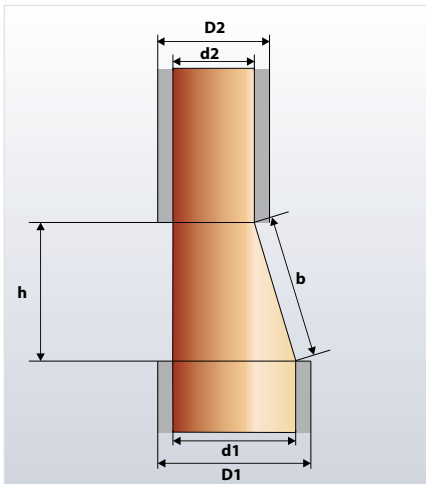

Determine the following measurements:

$h$  = height of the excentric reducer including both welds

$D1$  = diameter of the larger pipe + 2x insulation thickness

$D2$  = diameter of the smaller pipe + 2x insulation thickness

$b$  = true length of the reducer

Determine the circumference by placing a strip of ArmaFlex sheet material in the thickness to be used round the larger diameter pipe.

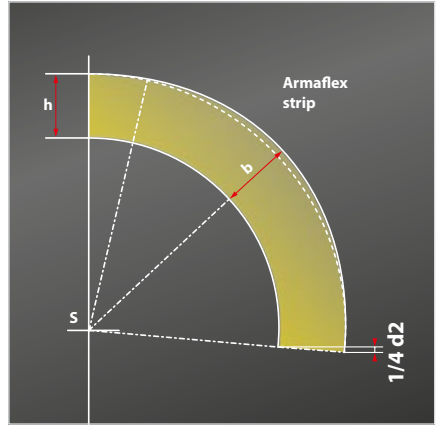
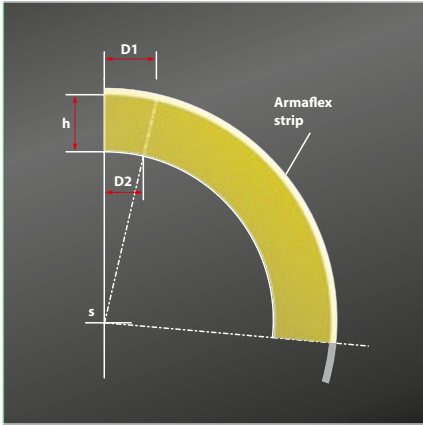

Transfer the measurement determined onto the surface of the ArmaFlex sheet material, as shown in the picture.

Modify the pattern as appropriate.

## Two-part bend made of ArmaFlex sheet with extension

In some cases flanges, valves etc. are located in close proximity to bends. In such situations it is practical to insulate this area as a single operation:

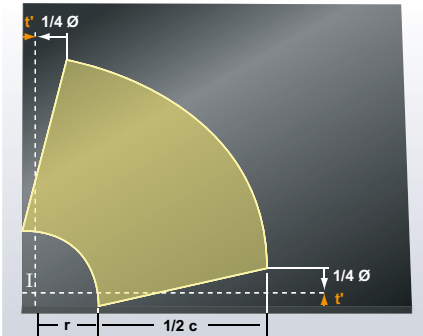

1. Fabricate a two-part bend (see "Two-part bend with ArmaFlex sheet" on page 32)

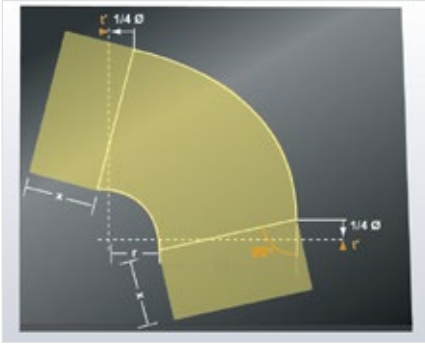

2. At both ends of the bend, mark the required extension “x” at a 90° angle.
3. Cut the first half-section of the extended elbow. Use the first half-section as a template to cut the second half-section of the elbow.
4. Place the sections together and apply ArmaFlex adhesive to the outer edges.
5. Allow the adhesive to tack dry and glue the pieces together (see “Two-part bend with ArmaFlex sheet” on page 32).

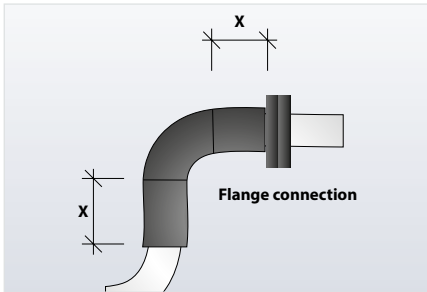

6. Place the insulation cover over the pipe bend. Allow the adhesive to tack dry then press the joint faces firmly together.

## Strainer valve insulation with ArmaFlex sheet

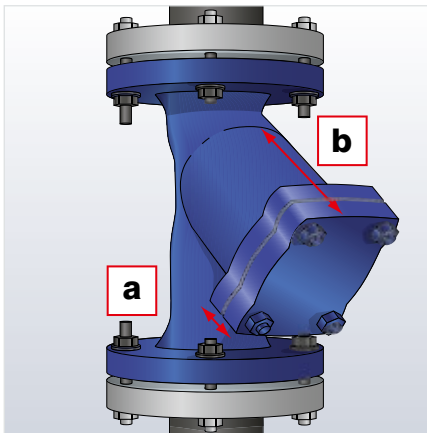

1. Insulate the incoming pipes up to the flange.
2. Measure the shortest distance “a” and the longest distances “b” of the end of the strainer to the uninsulated strainer valve body.
3. Determine the circumference of the removable cover of the strainer. Important: Always measure with a strip of ArmaFlex of the thickness to be used for the insulation. Do not stretch the strip.

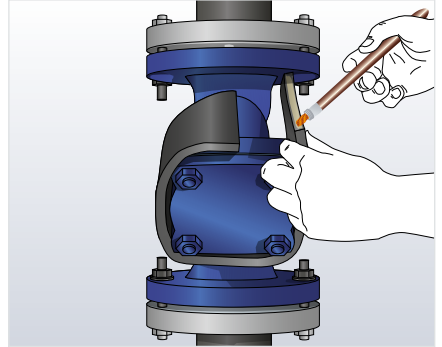
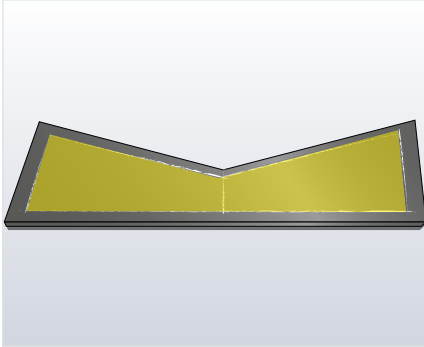

4. Transfer the circumference to ArmaFlex sheet and mark a centre line.
5. At each end mark the longest distance “b” from the end of the strainer to the uninsulated strainer valve body and at the centre line mark the shortest distance “a”.

**Note:** The strainer section may extend into the insulation of the strainer valve body and an additional length may be necessary so that the insulation of the strainer section juts out of the insulation of the strainer valve body.

6. Cut the piece out of the sheet material and attach the insulation to the strainer section using ArmaFlex adhesive.  
Attention: Do not glue to the edge of the removable strainer lid!
7. Using a pair of callipers determine the diameters of the:

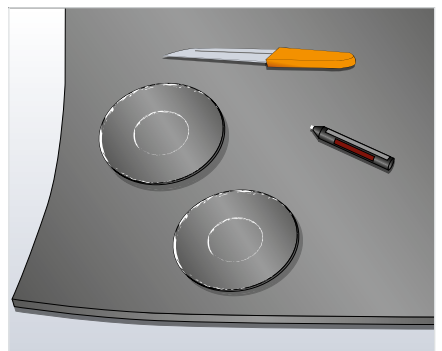
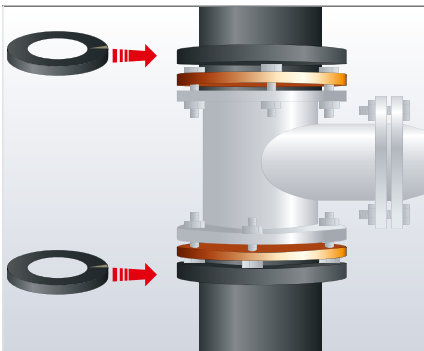

- insulated incoming pipes
- flanges of the strainer valve

8. Transfer these measurements to a piece of ArmaFlex sheet. Mark two concentric circles with dividers. Repeat on a second piece of sheet. Cut out two ArmaFlex rings and install on both flanges.
9. Measure the distance between the outer faces of the two ArmaFlex rings and the circumference of the disc by using a strip of ArmaFlex with the thickness to be used for the insulation.
10. Transfer the circumference and the height to the ArmaFlex.

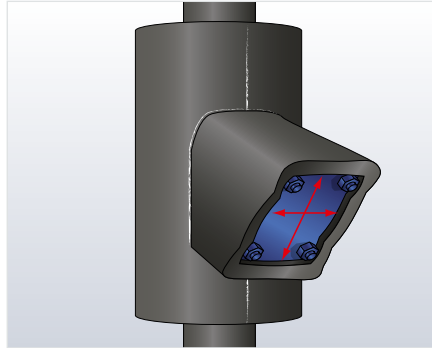
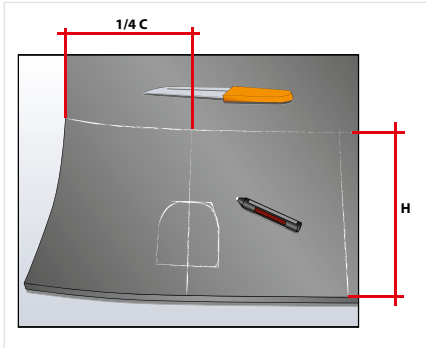

11. Mark a centre line and cut an outline for the strainer section. Cut the sheet and apply adhesive to the longitudinal seam. Attach the insulation to the strainer valve body using ArmaFlex adhesive.
12. Measure the height and the width of the strainer section including 2x insulation thickness, transfer to ArmaFlex sheet and cut out the disc for the end cover.
13. Determine the circumference of the disc. Always measure with a strip of ArmaFlex of the thickness to be used for the insulation. Measure the shortest and the longest distances from the end of the strainer to the insulated strainer valve body.
14. Transfer these measurements to ArmaFlex sheet as shown and connect the end-points with a divider.

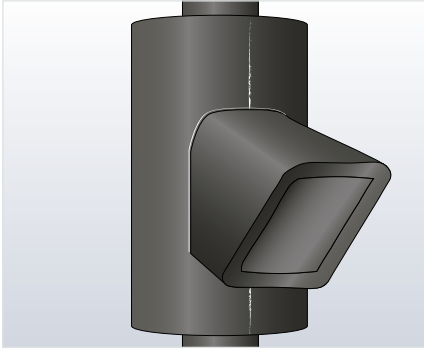

To the video



Cut the plotted shape and apply adhesive to all seams. Allow the adhesive to tack dry and roll the panel up around the end disc, do not stretch during application. Check alignment throughout.

15. Install strainer insulation and glue precisely to the strainer valve body.

**Note:** Although the strainer must be cleaned periodically, a removable cap is not recommended on cold applications.

## One-part T-piece with ArmaFlex sheet

1. Determine the pipe circumference “c” using a strip of ArmaFlex in the thickness which is also to be used for the insulation later.

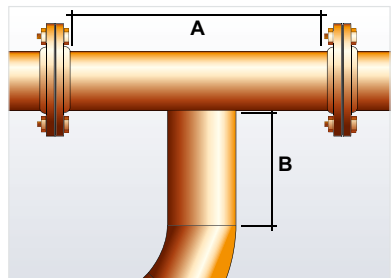
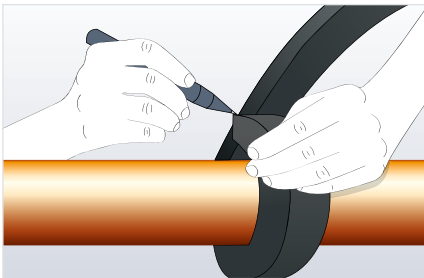

2. Measure the length A of the main pipe and the length B of the branch pipe.

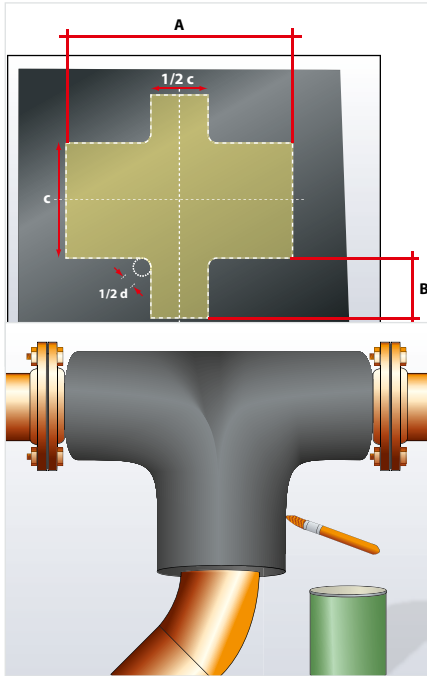

3. Draw horizontal and vertical reference lines on the ArmaFlex sheet material. Transfer the measurements determined as shown in the drawing.
4. To round off the corners, draw an arc with a radius equal to a quarter of the pipe diameter on all four corners and cut out the ... along the curves drawn.
5. Apply adhesive to all seams, allow to tack dry and then close around the T- piece.

To the video



## Insulating victaulic couplings with ArmaFlex sheet

1. Insulate pipes up to the coupling.

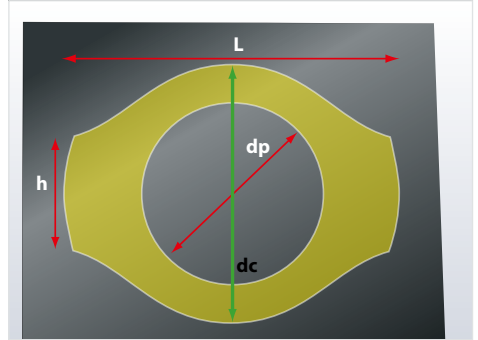
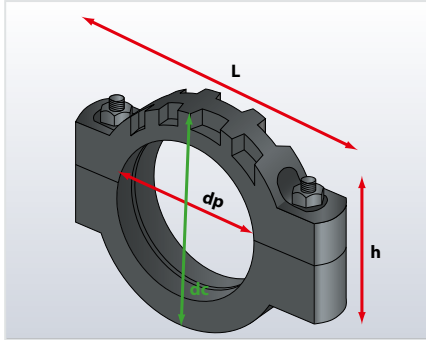

2. Determine  
 $dc = \text{diameter of coupling} + 2 \times \text{insulation thickness}$   
 $h = \text{height of screws} + 2 \times \text{insulation thickness}$   
 $L = \text{length of coupling}$
3. Using  $\frac{1}{2} dc$  (diameter coupling + 2 x insulation thickness) as a radius, transfer a circular arc to the ArmaFlex sheet and mark a horizontal centre line.
4. From the centre of the line, mark the width of the coupling.
5. At both ends, mark the height of the screws plus 2x insulation thickness at a  $90^\circ$  angle to the centre line.
6. Connect the four end-points and the circular arc with a tangent so that an oval-like disc is formed.
7. Determine the diameter of the insulated pipe and mark it on the ArmaFlex sheet.

8. Cut out this disc and use as a template to create a second identical disc.

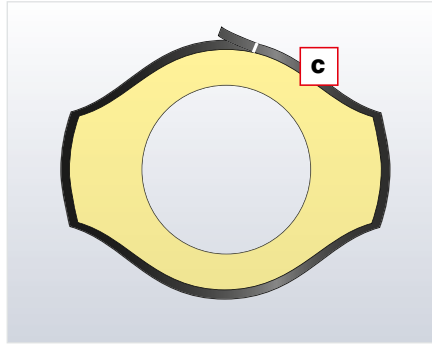
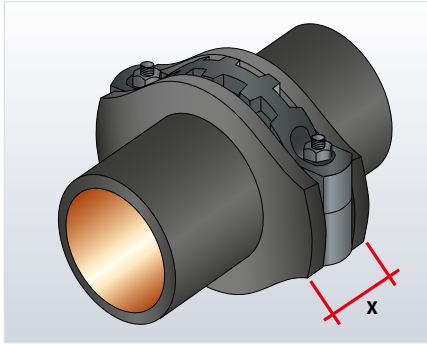

9. Glue both discs directly next to the coupling as shown.
10. Determine the circumference of the disc and measure the distance over the outer faces of the two discs.

Transfer these measurements to a sheet of ArmaFlex.

**Important:** Always measure with a strip of ArmaFlex of the thickness to be used for the insulation. Do not stretch the strip.

11. Cut this section and glue over the ArmaFlex discs around the coupling.

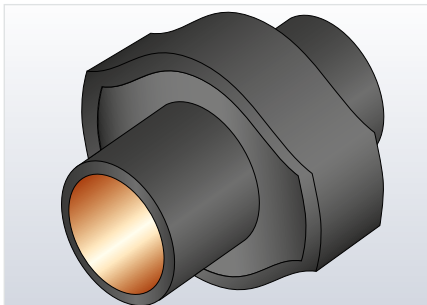

## Insulating pumps with ArmaFlex sheet

Various types of pumps are available. The following section offers general advice and procedures which can be applied and modified as required to insulate most pump configurations.

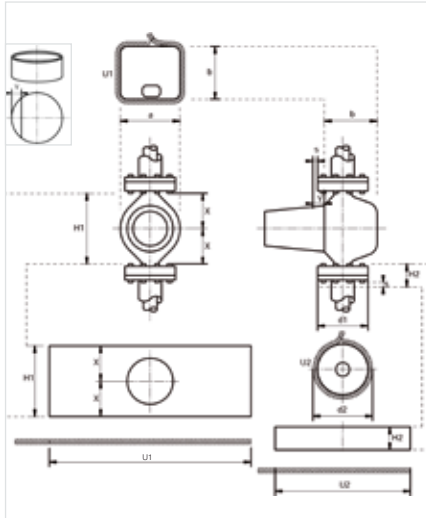

1. Insulate the incoming pipes up to the flange.
2. Cut to size two ArmaFlex discs including the cutouts according to the dimension of the pump body (a x b).
3. Determine the circumference of the disc (U1).

**Important:** Always measure with a strip of ArmaFlex of the thickness to be used for the insulation. Do not stretch the strip.

4. Cut out the section for the insulation of the pump body from an ArmaFlex sheet (U1 x H1).

5. Create the cutout for the motor pump. To provide a close-fitting cutout in the penetration area of the pump motor, it should be 5 mm smaller than measured.
6. Glue both discs to the section for the pump body. Place the insulation cover over the pump body and apply adhesive. Allow to tack dry then press the surfaces firmly together.

**Note:** In the area of the pump motor, apply self-adhesive ArmaFlex tape to the pump to ensure the insulation is attached securely.

- For the flattening fabricate two circular sections. Cut out discs with the dimension of flange diameter + 2 x insulation thickness. Mark the Y-dimension, cut the two circular sections and glue at the top and bottom of the pump cap.

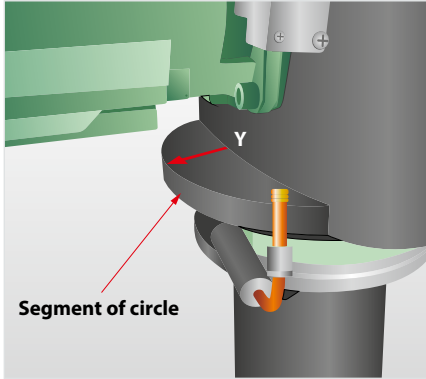

- Fabricate the flange boxes: determine the diameter of the flanges  $d_1$ , circumference  $U_2$ , the height  $H_2$  and the cut-outs for the insulated piping connections.
- Fit the flange boxes around the flange and wet seal all seams and joints.

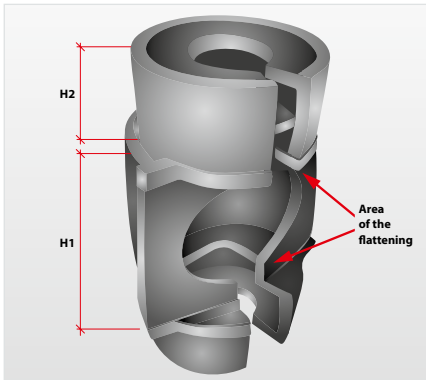

The picture shows a pump box with a straight front cover and a semi-circular shell.

## Installing ArmaFix insulated pipe supports

Where ArmaFlex is installed, the use of ArmaFix pipe supports is the preferred solution to prevent ice and condensation on cold installations. However, when ArmaFlex pipe supports are not selected, it is imperative to follow these instructions:

- Ensure that the ArmaFlex is fitted tight to the support with no air gaps and vapour-sealed with ArmaFlex adhesive.
- Install ArmaFlex self-adhesive tape to the butt joint where the ArmaFlex and the support meet. Ensure the surface of the butt joint is free from dust before installing the ArmaFlex tape.

ArmaFix pipe supports are sections of ArmaFlex with load bearing PET inserts and an aluminium outer shell cladding.

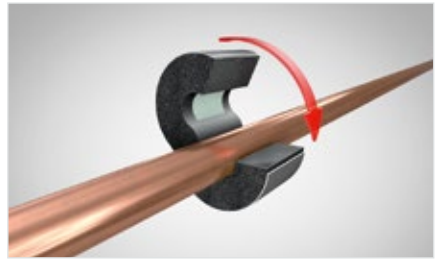
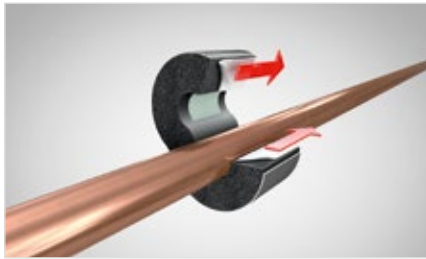

Install ArmaFix pipe support to the pipe, remove the white protective paper strip on both side. Close the seam applying firm pressure.

**Note:** Select the correctly dimensioned ArmaFix pipe support (min. insulation thickness of tube).



Install the brackets.

**Important:** Use only the PET segments to bear the load.

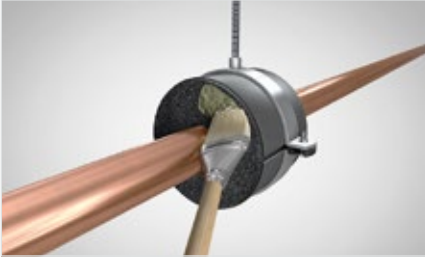

Install the ArmaFlex insulation on either side of the ArmaFix pipe support. Wet seal the butt joints with the ArmaFix pipe support using ArmaFlex adhesive. Note: Ensure that the pipe insulation is installed under slight compression.

## Insulating “over” pipe supports (encapsulating)

The insulation of standard brackets can be carried out using the following procedure: Note: When installing on cold lines, it is essential to raise concerns about the suitability of such systems before beginning work.

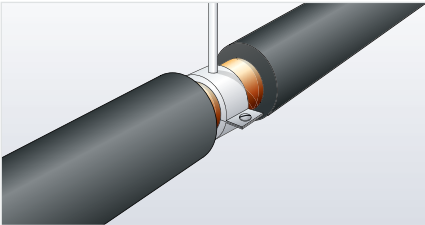

1. Install the ArmaFlex as close to the fixing bracket as possible. Seal the ends of the tube to the pipe with ArmaFlex adhesive.

**Note:** On cold lines, insulate the fixing bracket with a suitable ArmaFlex tube or with ArmaFlex self-adhesive tape.

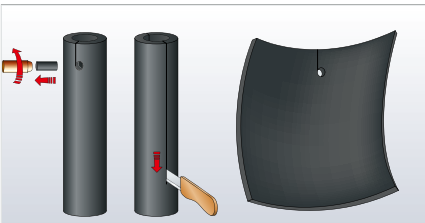

2. With a large off-cut of ArmaFlex tube, punch out a small hole to allow for the oil thread support of the bracket and slit with a small sharp knife along the flat face of the tube.

**Note:** For large pipe diameter the use of ArmaFlex sheet is recommended.

To the video

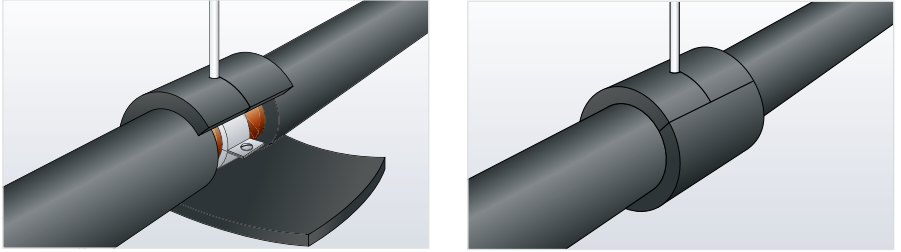

3. Place the ArmaFlex cover over the support area, mark and cut the true circumference of the cover.  
Fix and vapour seal all seams and joints in and around the attached insulation using ArmaFlex adhesive.

### Insulation of other pipe supports

ArmaFix pipe supports represent the best option to create a fully water-vapour-tight system and prevent condensation on cold applications.

Often, cold clamps made of PUR/PIR complete the pipe hanging systems.

In these cases it is important that a vapour-tight bond between the cold clamps and the ArmaFlex insulation is achieved.

This interface represents a thermal bridge where condensation may occur and adhesion at these points requires special attention:

1. Clean the surface of the clamp using ArmaFlex cleaner.
2. Apply ArmaFlex adhesive on the surfaces which are to be glued. Allow this first layer of ArmaFlex adhesive to dry.
3. Apply a second thin coat of adhesive evenly on both the surface of the clamp and the ArmaFlex adhesive joints. After the adhesive has cured, the joints should be pressed together briefly, but firmly.
4. When gluing both butt joints under pressure, wet seal around the joint, when the clamps have been glued in advance (please see above)
5. If necessary double the ArmaFlex thickness to the diameter of the PUR-support.
6. To secure the butt joints, apply an overlapping strip of ArmaFlex using all-over adhesive coverage.

**SCHEMATIC CROSS-SECTION OF A CONNECTION OF ARMAFLEX TUBES WITH A CLAMP MADE OF PU RIGID FOAM**

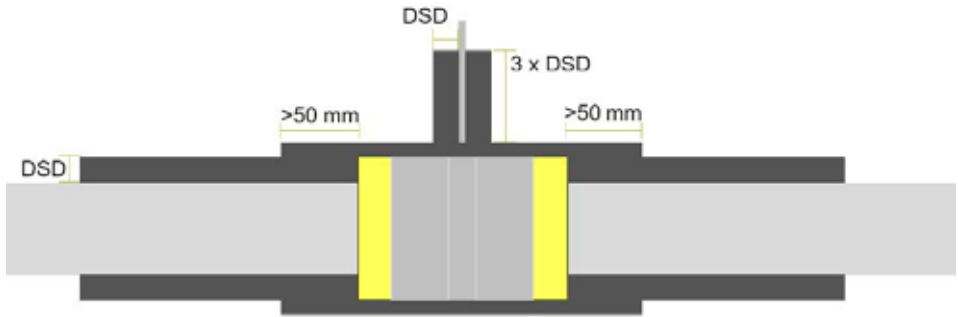

For further instructions, please ask your Armacell representative to send Technical Bulletin 15.

## Ducts

### Insulating rectangular ducts with ArmaFlex sheet

Measure surface dimensions and cut ArmaFlex sheet to size.

**Note:** Add 5 mm so that the material is fitted under compression.

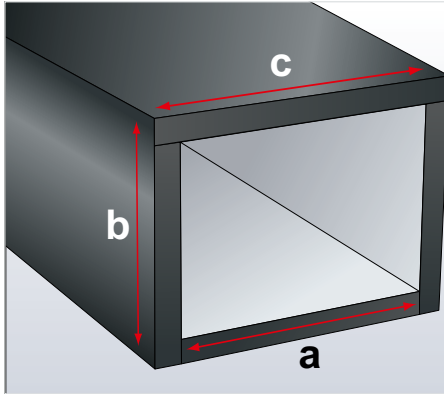

- a = width of duct + 5 mm
- b = height of duct + 5 mm + thickness of insulation
- c = width of duct + 5 mm + 2x thickness of insulation

Clean all surfaces using ArmaFlex cleaner to remove grease, oil, dirt etc. and cut sheets to size

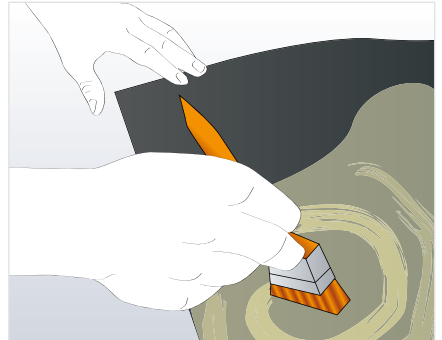
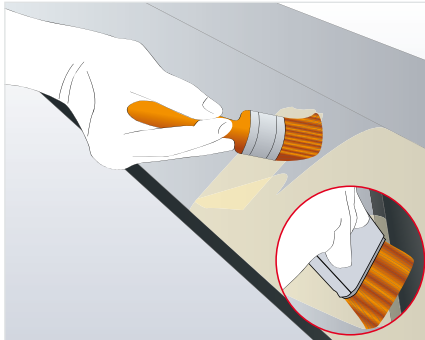

Spread a thin film of adhesive onto the metal surface and then onto the ArmaFlex sheet.

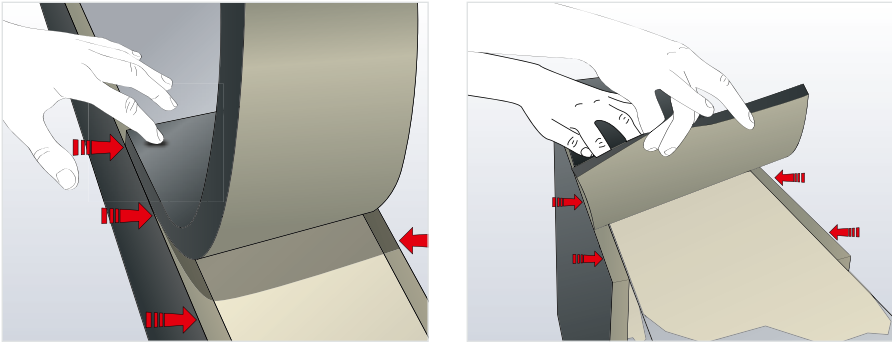

When the adhesive is tack dry (fingernail test) place ArmaFlex sheet in position and press firmly to achieve a good bond. Continue, applying ArmaFlex adhesive to both surfaces including the ArmaFlex edge, and allow to tack dry before pressing firmly into position.

**Note:** Remember to roll the sheet down into position along the insulated edges.

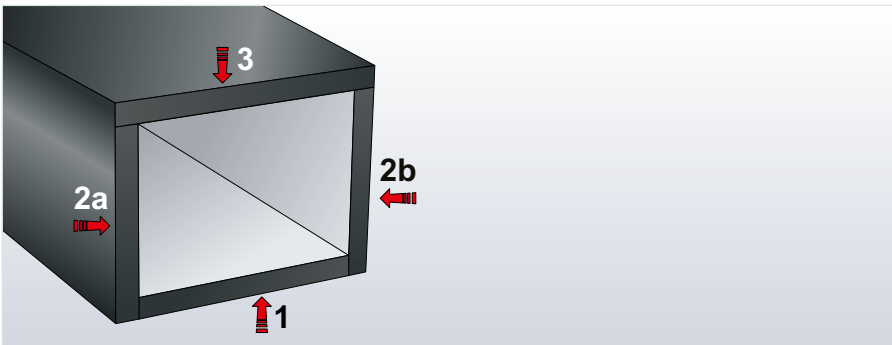

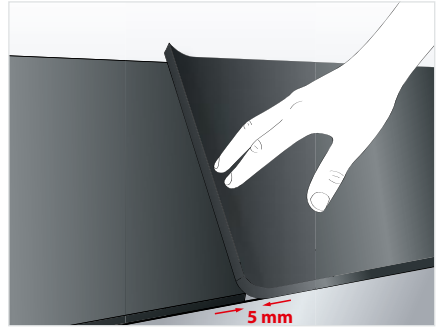
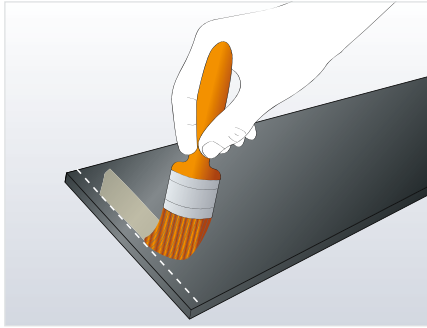

The cut sheets should be positioned so that there is a 5 -10 mm overlap (for compression). Do not apply adhesive to this area on either the ArmaFlex sheet or the duct surface. Where two sheets join, leave a 30 mm strip of both the sheet and the duct surface free of adhesive.

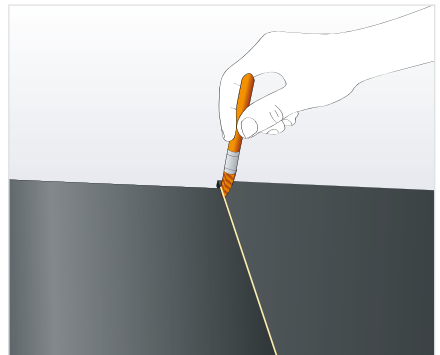
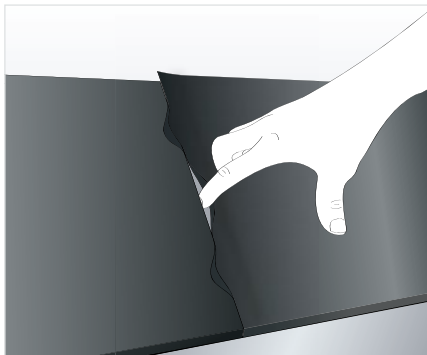

When pressed together, the material is under compression and not stretched.

Apply an additional wet seal along the butt joints.

## Insulating rectangular ducts with ArmaFlex self-adhesive sheet

Clean all surfaces using ArmaFlex cleaner to remove grease, oil, dirt etc. and cut sheets to size

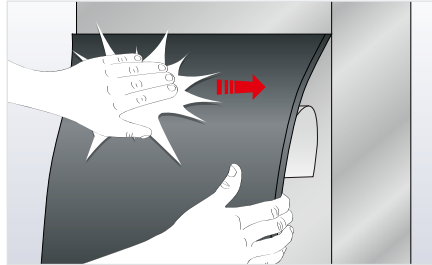
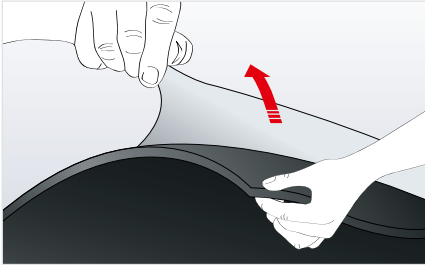

Peel back release paper 10 to 20 cm & line up sheet. Press firmly to activate adhesive.

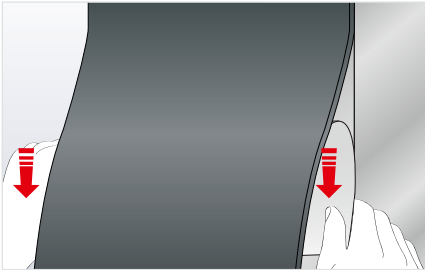

Align material and continue to line up correctly, pressing firmly whilst slowly removing release paper. At butt joints allow 5 mm overlap for compression

To allow the sheets to be overlapped, first re-stick an approximately 30-mm strip of the backing foil to the edge of the sheet.

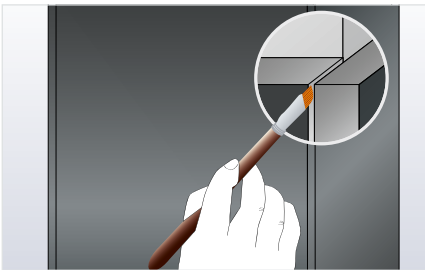

Wet seal the compressed butt joint.

To the video  
(also showing the  
insulation of duct  
flanges)



## Insulating duct brackets with ArmaFlex

### INSULATING DUCT BRACKETS USING ARMAFLEX TUBES

For a cost-effective solution with a high-end finish, ArmaFlex tube can be used to cover duct brackets.

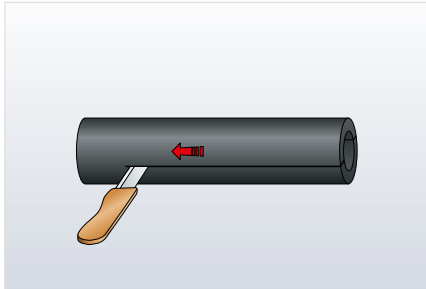

1. Use unsplit ArmaFlex tube in a thickness equal to the duct insulation. Split the tube into two equal halves using a sharp knife.
2. Measure the four insulated sides of the duct body.
3. Using a mitre box, or the ArmaFlex template, cut the ArmaFlex as shown with a 45° angle. From the throat measurement, determine the length of the fitting and cut an opposite 45° angle as shown.
4. Continue to cut the other 3 sides of the tube picture frame fitting.

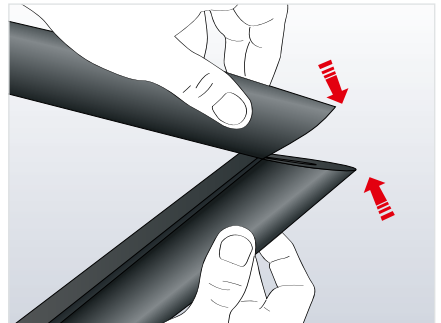
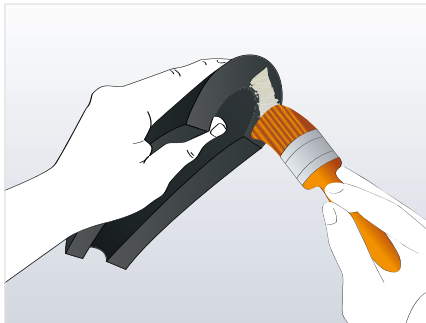

5. Using ArmaFlex adhesive, apply a thin even film with a brush to the three sets of 45° angles.

6. Allow the adhesive to tack dry and press the angles together, applying firm even pressure for a good bond.

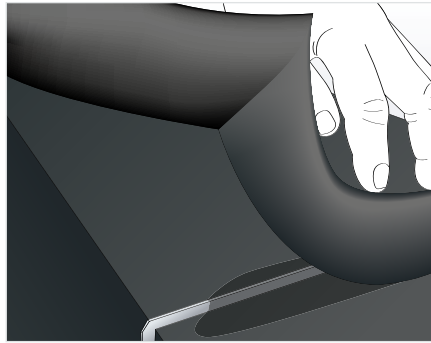
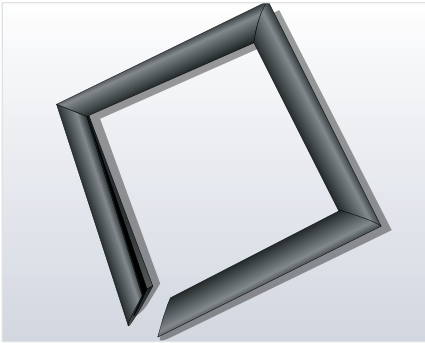

7. Place the picture frame of ArmaFlex tube material around the ducting, apply the adhesive to the final angle cuts and bond to complete.
8. To finish, wet seal around the picture frame fitting cover.

## INSULATING DUCT BRACKETS USING ARMAFLEX SHEET



Single strip method - Four single strips applied to the insulation.



Three-sided box method - Built up side strips with over-covering body strips.



Continuous single strip method - Complete single continuous strip.

In all these cases the fabricated ArmaFlex insulation bracket covers have the same thickness as the attached ductwork connections. For a continuous vapour-tight system, all insulation covers should be securely fixed and wet sealed with ArmaFlex adhesive.

## Insulating circular ducts with ArmaFlex sheet

For circular ducts proceed as described in the sections "Insulating large pipes with ArmaFlex sheets" and "Use of adhesive on pipes with outer diameter > 600 mm".

# Vessels and tanks

## Insulating vessels and tanks with ArmaFlex sheet

### DRAW UP A CUTTING SCHEDULE

Work out the most efficient way of covering the surfaces using ArmaFlex sheet (2 x 0.5 metre) or continuous roll (1m width and length 3 - 15 m depending on the thickness).

### ArmaFlex sheet layout for large vessels and tanks

**Note:** ensure that sheet joints are staggered.

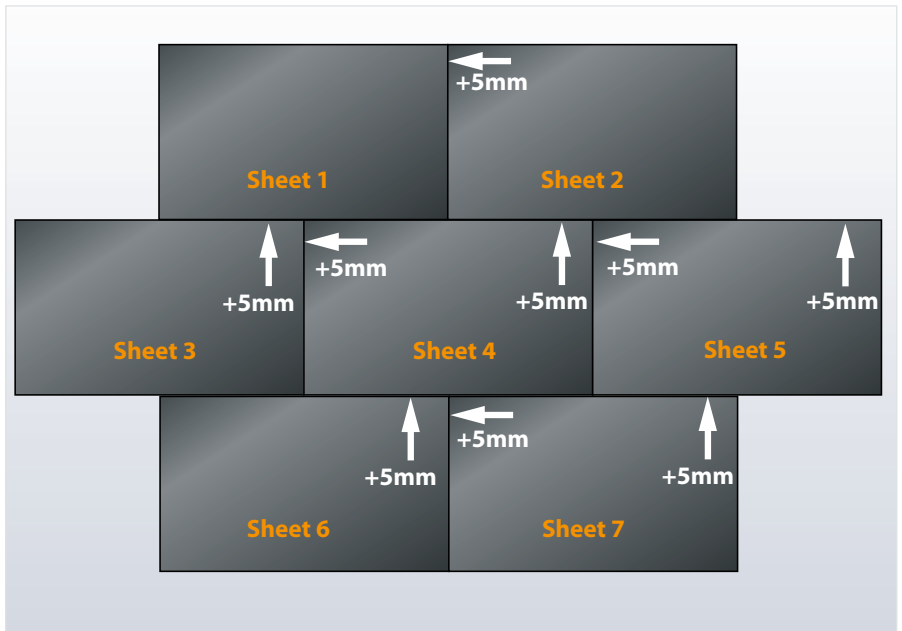

### COMPRESSION JOINTS

Provide an allowance of an additional 5 mm on all dimensions when cutting from ArmaFlex sheet or roll.

Always make compression joints. On curved surfaces, measure the circumference with a strip of ArmaFlex of the same thickness to be used for the insulation, including any surface finish. Do not stretch the strip.

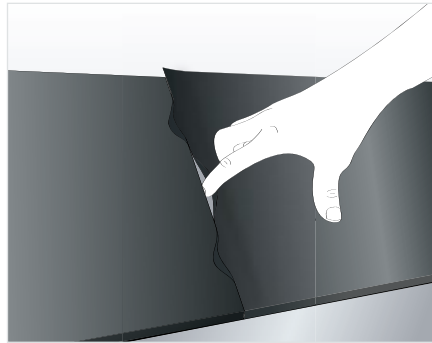
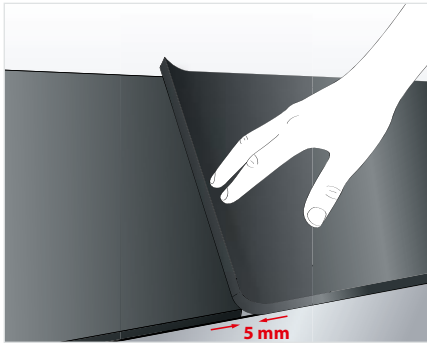

## ADHESION

Apply ArmaFlex adhesive first to the insulation before applying adhesive to the metal surface.

All seams are joined wet. Leave about 30 mm without an adhesive coating on the ArmaFlex surface. Attach the connecting sheet with adhesive and with 5 mm overlap. Then press in the overlapping butt joint to give additional compression.

Wet sealing of joints on flat surfaces:

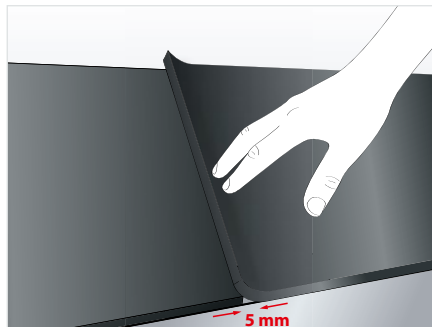
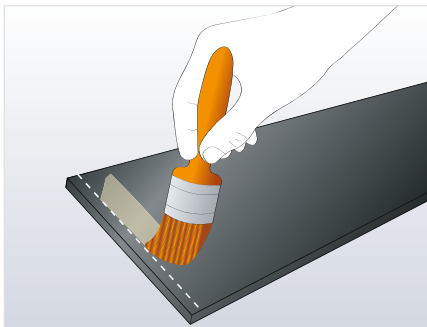

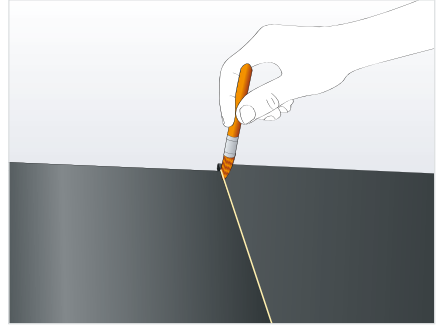
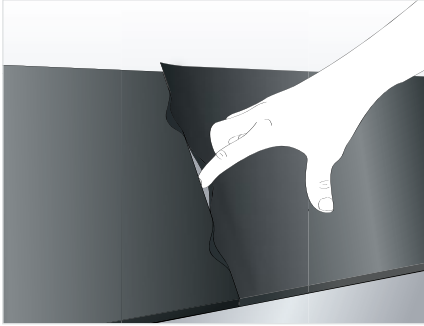

### **MULTI-LAYER APPLICATION**

Where multi-layer insulation is installed use ArmaFlex cleaner after 36 hours (see “Multi-layer insulation of pipework” on page 22) to remove any talc, chalk, dirt, grease and moisture from the surfaces to be joined. Stagger all seams and butt joints on the second layer relative to the first layer.

### **COMPLEX SHAPES**

Where complex shapes are to be insulated, the shape of the body is outlined with chalk and these chalk markings can be transferred directly to the ArmaFlex sheet by pressing the flexible material against the metal surface. Cut along the chalked line with a sharp knife to obtain a good fit for the ArmaFlex.

### **OUTDOOR INSTALLATIONS**

All ArmaFlex materials (except HT/ArmaFlex and NH/ArmaFlex Smart) used outdoors will require additional protection against UV radiation. We recommend the use of ArmaFinish 99 paint or one of the Arma-Chek Systems (see “Outdoor use of ArmaFlex” on page 13). HT/ArmaFlex and NH/ArmaFlex Smart insulation does not require painting when used outdoors.

## Insulating small ( $\varnothing < 1.5$ m) tanks and vessels using ArmaFlex sheet

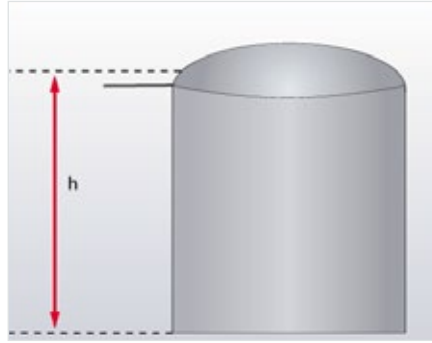
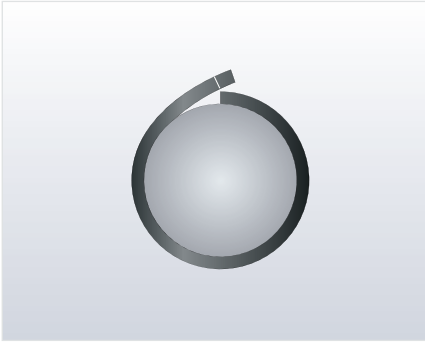

1. Determine the circumference of the tank.

**Important:** Always measure with a strip of ArmaFlex of the thickness to be used for the insulation.

**Warning:** Do not stretch the strip.

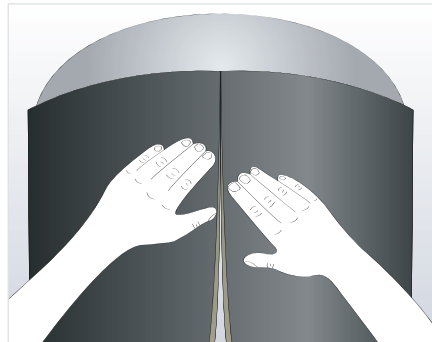
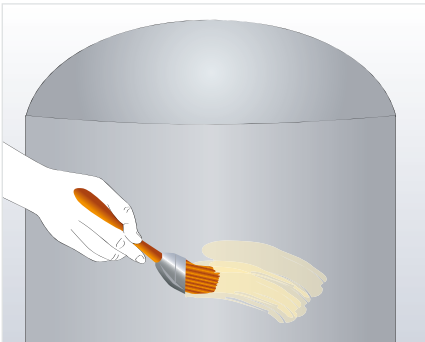

2. Transfer the circumference to the ArmaFlex sheet and cut to the required size. Spread a thin film of adhesive onto the ArmaFlex sheet and then onto the metal surface. When the adhesive is tack dry (fingernail test) place ArmaFlex sheet in position and press firmly to achieve a good bond. Depending on the size of the tank, allow the ArmaFlex sheet to overlap the weld joint in the region of the dome of the vessel head by approximately 10 to 20 cm.

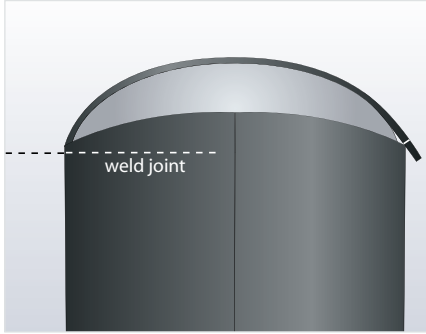

3. Determine the curve length of domed surface.

**Important:** Always measure with a strip of ArmaFlex of the thickness to be used for the insulation.

**Warning:** Do not stretch the strip.

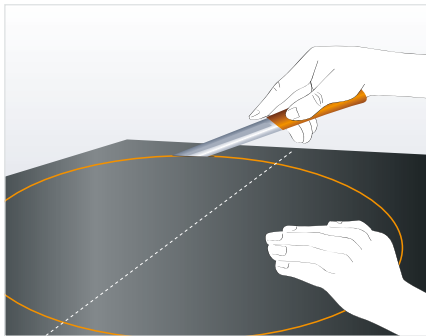

4. Using the curve length as the diameter, mark a complete disc on a piece of ArmaFlex sheet. If this disc is too large to fit on a single sheet of ArmaFlex first glue multiple sheets together.
5. Cut around the disc.
6. Spread a thin film of adhesive onto the back of the ArmaFlex sheet and then onto the metal surface.

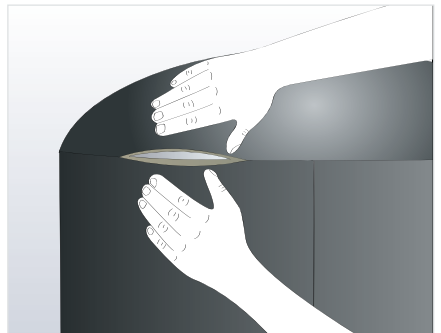
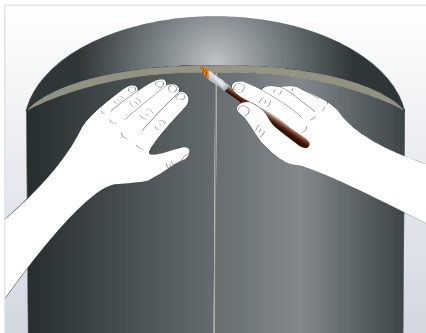

7. When the adhesive is tack dry (fingernail test) place ArmaFlex sheet in position onto the top of the tank and press firmly down from the centre, avoiding any slipping of the material, to achieve a good bond.
8. Apply an additional wet seal along the edges at the top of the tank.
9. After the adhesive has been given time to tack dry, press the edges of the seam firmly together.



To the video

## Key basic application procedures for large vessels $\varnothing > 1.5 \text{ m}$

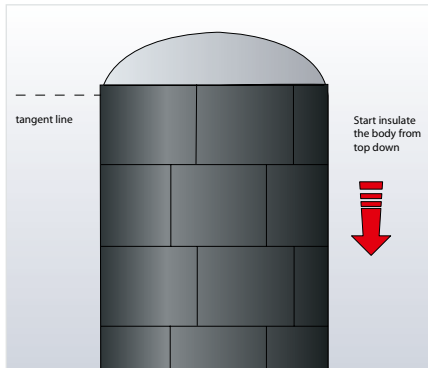

Install the ArmaFlex sheet panels from the domed end section of the vessel as shown. Use all-over adhesive coverage to both surfaces.

Continue to install the panels of ArmaFlex around this domed end section. Ensure the ArmaFlex sheet is fitted under compression. After the first ring of panels are installed, continue to apply other panels of ArmaFlex sheet around the body of the vessel as shown.

When the entire surface area of the vessel body is completed, insulate the dome ends as shown.



To determine the exact shape of the edge sheets, mark the edges of the ArmaFlex used to insulate the vessel body with white chalk.

For the edges of the domed end section, cut sheets roughly to size with an overlap of approx. 50 mm. Place sheets over the chalked edges and apply firm pressure and remove. The underside of the ArmaFlex sheet will show the impression of the required profile.

Cut the marked outline with a shape knife and install directly to the appropriate section with all-over adhesive coverage.

**Note:** Do not apply adhesive to the circular profile edges of the domed end. This is done last by wet sealing the jointing details as described below.

Continue to install the required insulation panels as required to complete the domed section.

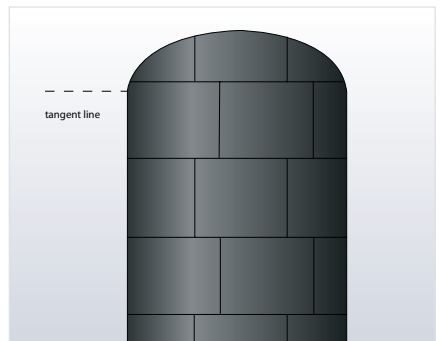
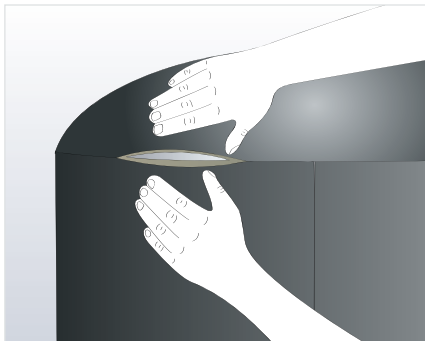

To finish, wet seal the domed panels to the main insulated body sections as shown in the section relating to vessels with diameters smaller than 1.5 m.

## Vessel insulation with metal jacket

### ArmaFix FLAT SUPPORT – INTEGRATED PROTECTION AGAINST MECHANICAL DAMAGE

When insulating a vessel head with ArmaFlex, the ArmaFix flat support can be integrated as a load-bearing substructure. It is used if the ArmaFlex insulation is to be clad with a metal jacket which will then be subject to mechanical compressive stress (e.g. if it will be trodden on in the course of inspections).

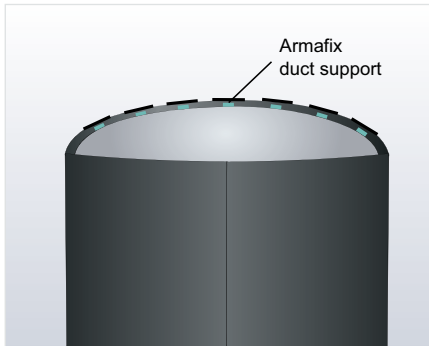

Cut the flat support strips to the required length following the arc of the vessel head. Then centre and glue in place applying the ArmaFlex adhesive all over both surfaces of the flat supports.

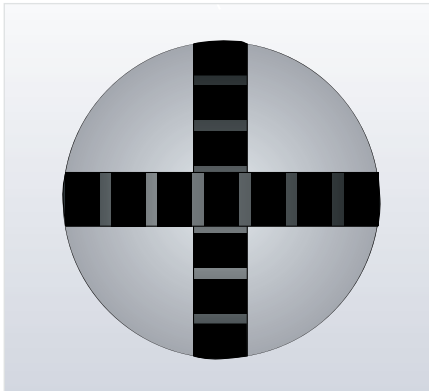

For small vessels (< 1000 mm  $\varnothing$ ) a crosswise arrangement is generally recommended. For large vessels, several flat support strips can be installed in a radial symmetric pattern. The arrangement can, however, be varied to suit individual requirements.

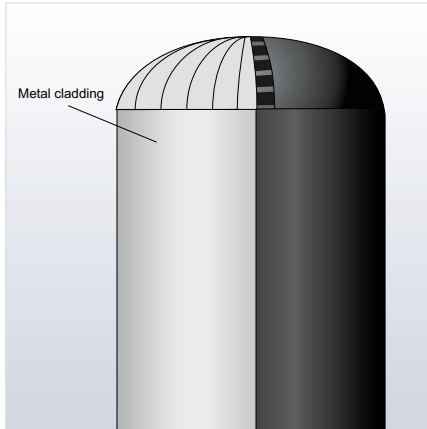

The remaining surfaces of the vessel head between the glued flat support strips must be fully insulated with ArmaFlex sheet material. The pieces should be cut at least 5 mm larger than the dimensions determined in order to guarantee that they are installed under compression. The picture also shows the final partial metal jacket clearly resting on the flat support system.

## Additional application advice

The following sections contain further detailed information for specific applications.

### ArmaFlex with additional metal cladding

Sometimes an additional metal cladding is needed to protect ArmaFlex against mechanical damage and, in outdoor applications, UV radiation.

If such cladding is used, it is necessary to bear in mind that the metal cladding may influence the insulation thickness required. In particular the altered surface emissivity will have an impact on the surface coefficient of heat transfer to be used in calculations.

It is considered best practice to install the metal cladding directly onto the ArmaFlex leaving no air gap. Since fixing screws will be directly inserted into the ArmaFlex, thermal bridges will be created and the insulation wall thickness may need to be increased to compensate for this.

Alternatively, the cladding can also be installed with an air gap (minimum 15 mm) by using strips of ArmaFlex as spacers. In addition, holes with a diameter of 10 mm should be drilled in the underside of the cladding at least every 300 mm.

**Note:** It is important to ensure that condensation does not occur within this air layer or on the surface of the aluminium cladding. Always pay careful attention to the changing surface coefficient of heat transfer as this can seriously impact upon the insulation thickness requirement.

### ArmaFlex installed in the soil

Pressure of soil backfilled on top of the ArmaFlex will cause compression of the material, which will have an impact on the insulation wall thickness.

It is recommended that ArmaFlex is protected against compression by sleeving the insulated pipe into a rigid soil or waste water drainage pipe.

1. Prevent compression of flexible cellular material due to contact with the outer protective pipe by selecting a drainpipe which is sufficiently larger than the outer diameter of the insulated pipe assembly to be inserted.

2. Ensure the outer protective pipe is fully supported, e. g. by having full contact with the surrounding soil, to prevent the drainpipe breaking. Joints and connections are particularly vulnerable.

## Installation of ArmaFlex insulation on plastic pipes

ArmaFlex insulation materials and ArmaFlex Adhesive 520, ArmaFlex 525, ArmaFlex 750 and HT625 are compatible with most plastic pipe materials which are used for industrial and building service equipment. On pipes made of PVC-C, PE-Xa and PE-HD plastics, ArmaFlex can simply be installed in the same way as on metal pipes.

However, when bonding ArmaFlex to polypropylene (PP) pipes, it is necessary to bear in mind that the adhesion of the material is not optimal. Therefore, to improve the bond, Armacell recommends first roughening the plastic where the partition bonding is to be carried out.

When ArmaFlex is glued to ABS pipes, solvent from the ArmaFlex adhesive may be trapped. During the aging process of the ABS plastic, this can lead to hair cracks in the pipes. Direct partition bonds should therefore not be used on ABS pipes (except ArmaFlex ECO550 and ArmaFlex Ultima ECO550). However, it is possible to first apply self-adhesive ArmaFlex Tape where the partition is to be created and then carry out partition bonding. In contrast, this is not necessary when the longitudinal seams are glued. Here it can be assumed that if the work is carried out correctly, the solvent present in the applied adhesive will have evaporated before the insulation is glued together.

### Compatibility of ArmaFlex and ArmaFlex adhesive with plastic pipes

Plastic pipe	Compatibility	Remarks
PVC-C	yes	-
PE-Xa	yes	-
PE-HD	yes	-
PP	yes	To improve bonding - e.g. where partition bonds are to be carried out - first roughen the plastic
ABS	yes	In the case of partition bonding, first apply self-adhesive ArmaFlex Tape where the partition is to be created, then carry out partition bonding. Note: For Durapipe ABS pipes at medium temperatures greater than 30 °C the use of HT/ArmaFlex or NH/ArmaFlex should be considered.

## References

In addition to this manual, Armacell provides the following documents, free of charge. Please ask our Customer Service Center.

### **INSULATION OF STAINLESS STEEL WITH ARMAFLEX**

### **CORROSION PROTECTION IN THERMAL AND REFRIGERATION INSULATION ON TECHNICAL OPERATING SYSTEMS**

### **ARMAFLEX COLD WORK APPLICATION GUIDANCE**

Insulating cold lines with temperatures between  $-50\text{ }^{\circ}\text{C}$  to  $-196\text{ }^{\circ}\text{C}$ .

### **GLUING ARMAFLEX ONTO CELLULAR GLASS**

Installation advice when installing ArmaFlex directly onto a cellular glass surface.

### **OTHER APPLICATION GUIDES**

- Application Guide for Arma-Chek products
- Special Application Advice for HT/ArmaFlex
- Application of ArmaFlex DuoSolar VA
- Application guide for ArmaSound Industrial Systems
- Application videos
- ArmaFlex EC0550 Application Manual

## Calculation tools

### **ARMAWIN**

Armawin is the technical calculation program to determine insulation thicknesses required to prevent surface condensation and limit energy losses.

It also allows users to calculate U-values, heat flows and temperature changes for pipes, ducts and tanks.

### **keytec. ISO 15665**

Determine the right ArmaSound Industrial Systems

## ArmaFlex products

### **AF/ARMAFLEX**

AF/ArmaFlex is a reliable flexible insulation material with a long term performance in condensation control. This is achieved thanks to the unique combination of extremely low thermal conductivity and a high water vapour diffusion resistance. The additional advantages are a longer life-time expectancy and higher energy efficiency of the insulated installation. This results in additional energy cost savings during the service life of the equipment. Due to the unique microcell structure, the new AF/ArmaFlex has more stability, making it even easier to install. Your advantage: the quicker and easier installation saves even more time and money.

### **AF/ARMAFLEX EVO**

AF/ArmaFlex Evo is the insulation material for higher fire safety. With a B/B<sub>L</sub>-s2, d0 fire class and 50% lower smoke development, it makes a significant contribution to the safety of buildings. The usual processing quality is of course also given with this product.

### **SH/ARMAFLEX**

SH/ArmaFlex is a flexible elastomeric insulation material which optimises the performance of heating and plumbing installations. The supervised technical properties and new microcell structure offer multiple benefits

### **HT/ARMAFLEX**

Naturally UV-resistant, closed-cell, EPDM rubber-based ArmaFlex insulation material capable of operating at line temperatures up to 150 °C.

### **NH/ARMAFLEX**

Halogen-free, closed-cell, nitrile rubber-based ArmaFlex insulation material with a low smoke toxicity rating. Achieves a number of maritime fire performance certificates.

### **NH/ARMAFLEX SMART**

The halogen-free, closed-cell insulating material for use in buildings provides additional safety due to its low smoke toxicity. The usual ArmaFlex quality is also guaranteed with this product.

**ARMAFLEX ULTIMA**

Flexible elastomeric foam on the basis of a patented synthetic rubber composition with improved fire-retardant properties, low smoke generation and a closed-cell material structure. For use in HVAC, refrigeration and process equipment applications.

**ARMAFLEX DUOSOLAR**

Parallel stainless-steel or copper pipes pre-insulated with naturally UV-resistant, closed-cell, EPDM rubber-based ArmaFlex insulation. Insulation comes with a tough black covering pre-applied. Designed to withstand the temperatures associated with solar hot-water systems.

**ARMAFIX PIPE SUPPORT**

ArmaFlex sections with load bearing PET inserts and an aluminium outer cladding to prevent excessive material compression.

**ARMAFLEX ACCESSORIES**

Armafinish 99 paint for visual impact and to prevent damage from UV exposure when ArmaFlex is used outside.

All data and technical information are based on results achieved under the specific conditions defined according to the testing standards referenced. Despite taking every precaution to ensure that said data and technical information are up to date, Armacell does not make any representation or warranty, express or implied, as to the accuracy, content or completeness of said data and technical information. Armacell also does not assume any liability towards any person resulting from the use of said data or technical information. Armacell reserves the right to revoke, modify or amend this document at any moment. It is the customer's responsibility to verify if the product is suitable for the intended application. The responsibility for professional and correct installation and compliance with relevant building regulations lies with the customer. This document does not constitute nor is part of a legal offer to sell or to contract. At Armacell, your trust means everything to us, so we want to let you know your rights and make it easier for you to understand what information we collect and why we collect it. If you would like to find out about our processing of your data, please visit our [Data Protection Policy](#).

© Armacell, 2025. All rights reserved. Trademarks followed by ® or TM are trademarks of the Armacell Group.  
ArmaFlex Application Manual | Manual | 012025 | EMEA | EN MASTER

## ABOUT ARMACELL

---

As the inventors of flexible foam for equipment insulation and a leading provider of engineered foams, Armacell develops innovative and safe thermal, acoustic and mechanical solutions that create sustainable value for its customers. Armacell's products significantly contribute to global energy efficiency making a difference around the world every day. With 3,300 employees and 25 production plants in 19 countries, the company operates two main businesses, Advanced Insulation and Engineered Foams. Armacell focuses on insulation materials for technical equipment, high-performance foams for acoustic and lightweight applications, recycled PET products, next-generation aerogel technology and passive fire protection systems.

For product information, please visit:  
[www.armacell.com](http://www.armacell.com)