



EDITION 2025

K-FLEX® APPLICATION MANUAL



K-FLEX® APPLICATION MANUAL

INDEX

Introduction	Pg. 3
Insulation of pipes (up to 125mm)	Pg. 7
Insulation of pipes (with standard or self adhesive tubes)	Pg. 8
Insulation of elbows (up to 125mm)	Pg. 9
Insulation of "T-fittings" (up to 125mm)	Pg. 13
Insulation of valves (up to 125mm)	Pg. 15
Insulation of reducer (up to 125mm)	Pg. 16
Insulation with pipe supports	Pg. 17
Insulation of end caps	Pg. 17
Insulation of pipes (over 125mm)	Pg. 19
Insulation of elbows (over 125mm)	Pg. 21
Insulation of "T-fittings" (over 125mm)	Pg. 23
Insulation of reducer (over 125mm)	Pg. 25
Insulation of flanges	Pg. 26
Insulation of valves (over 125mm)	Pg. 28
Insulation of tanks	Pg. 34
Insulation of ducts	Pg. 36
Insulation with PVC foil	Pg. 37
Insulation with ALU	Pg. 39
Insulation with K-FONIK	Pg. 42
Insulation with K-ROCK	Pg. 44
Insulation with PU	Pg. 46

Insulating piping for cooling, heating or air-conditioning systems requires a methodical approach, as well as the right tools to do the job properly.

K-FLEX® products are backed up by a comprehensive range of accessories specifically designed to help the installer.

This manual contains a wealth of information and practical tips, along with clear, step-by-step, illustrated instructions to ensure you get the best results quickly and easily.

GUIDE TO SYMBOLS



A **blue arrow**: indicates parts or sections to be glued.



Green lines and arrows: indicate a dimension to be measured.



A **red line with an arrow**: indicates the direction for measuring or fitting.

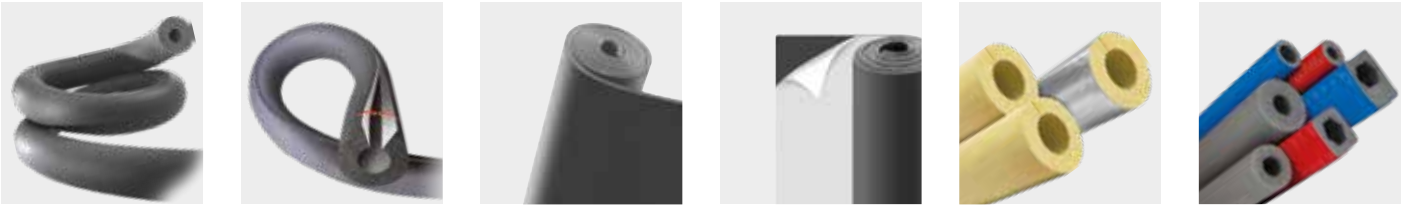

K-FLEX® produces flexible elastomeric foam, polyethylene and mineral wool insulating pipes and sheets.

Self-adhesive versions are also available.

A variety of product types, from tubing to flat sheeting, is available with specific technical characteristics for individual applications. Whenever applied outdoors K-FLEX® products must be covered or clad for UV and weather protection (e.g. Aluminum, steel, K-FLEX® AL CLAD, K-FLEX® IC CLAD or K-FLEX® IN CLAD)

Where the tubing has to be cut for applications purposes, its thermal insulating characteristics are maintained using the proper K-FLEX® glue.

With large diameter pipes or conduits, insulation is carried out using elastomeric sheets cut to size.

For technical information on K-FLEX® products and details of sizes available, please refer to the individual data sheets which are available from K-FLEX® Technical Dept.

K-FLEX® recommends that fitting has to be carried out to the highest possible standards to optimise the insulation effectiveness.

ACCESSORIES

K-FLEX® ADHESIVES



K-FLEX® provides different types of adhesive: K-414 for the most common civil application K-420 recommended for high performance insulation in both civil and oil&gas project K-425 recommended for high temperature insulation with SOLAR HT insulation product



K90 ELBOWS and "TEES"

A useful accessories pre-cut in the thickness and diameter required.

K-FLEX® THINNER



It is recommended that surfaces to be insulated should first be cleaned with K-FLEX® thinner, which is suitable for use with K-FLEX® glue. The glue will adhere perfectly to surfaces cleaned with the proprietary thinner. K-FLEX® thinner can also be used to clean tools (brush, spatula, etc.).



K-FLEX® INSULATED PIPE SUPPORTS

Specifically designed to ensure that thickness of the insulating material is absolutely correct, especially in the fixing points.

K-FLEX® FINISH



K-FLEX® finish is an acrylic paint that can be diluted in water to protect insulation both indoors and outdoors. The paint is environmentally safe and odorless, making it particularly suitable for use in confined spaces. It gives a professional, durable finish. It dries rapidly, and provides excellent coverage. When used as a primer, subsequent layers of white paint retain their color even in dark surroundings. Colors are fade resistant.



K-FLEX® ADHESIVE INSULATING TAPE

Special, 3mm thick, selfadhesive, 5 cm wide insulating tape for covering gaps or sealing insulated sections.

K-FLEX® GLUE DISPENSER



K-FLEX® GLUE DISPENSER

It facilitates the gluing of the surface avoiding the continuous dipping of the brush in the can. The controlled flow of the adhesive allows proper and regular quantity on the surface to glue.

USING PRODUCTS AND ACCESSORIES

CLEANING SURFACES

The surfaces to be glued must be perfectly clean and free of grease (use K-FLEX® thinner). Ensure that the surface of the K-FLEX® insulating material is also clean, otherwise it will not stick properly.

COATED SURFACES

Where surfaces have previously been painted, ensure that the K-FLEX® glue is compatible and will adhere to the paint. Do not use K-FLEX® glue on surfaces that have been treated with products containing asphalt, bitumen or linseed oil. Use only chrome-zinc rust inhibitors and removers.

USING THE GLUE

Preparation and storage: Before use, stir the K-FLEX® glue thoroughly.

To store the glue, close the lid tightly to prevent the solvents evaporating.

If the glue should become too hard (eg. when stored in contact with the air), dilute with K-FLEX® thinner. At low ambient temperature, don't dilute but heat it up to approx 20°C.

Method of application: When using a large quantity (eg. a tin of 2.6 litres), pour a small amount out into a separate container and top off when necessary. When applying K-FLEX® insulation to metallic or other surfaces, the glue must first be applied to the insulating material, then to the corresponding surface.

Conditions for use: Do not apply to systems that are in use.

Do not use in sunlight. Weather protect where is possible.

The insulation should be left to dry for 36 hours before turning the system back on.

The ideal working temperature of the glue is +20° C.

Do not use K-FLEX® glue at temperatures below +5° C as drying times are excessive.

At temperatures above +30° C, the glue dries very rapidly.

Dilute K-FLEX® glue using K-FLEX® Thinner only.

In case of spray application, dilute K-FLEX® glue up to max 5%.

HARDENING TIME : 36 hours

STORAGE : in cool conditions, away from cold and heat

SHELF LIFE : one year

QUANTITIES USED : with insulation sheets, approx 7m2 per liter

Note: K-FLEX® products are always tested and certified in combination with K-FLEX® adhesives and must be installed accordingly. The appropriate K-FLEX® adhesives for each type of insulation material can be found in our catalogues.

When using third-party products in conjunction with K-FLEX® materials, compatibility cannot be guaranteed.

CHOOSING K-FLEX® INSULATING MATERIAL

Before starting, choose the right type of K-FLEX® insulation for the parts to be lagged. Use the thicknesses and sizes which are most suitable for the individual parts of the installation. Don't forget - your K-FLEX® dealer can give expert advice.

USING K-FLEX® INSULATION MATERIAL

Insulating tubing that is oval or flattened (eg. the larger cross-sections) should be cut along the flattened surface

USING REFRIGERATION PLANTS AND AIR -CONDITIONING SYSTEMS

- Treat steel surfaces with rust inhibitor prior to applying insulation.

The paint should be left for a minimum of 24 hours to dry.

- Take special care over glueing critical areas such as curved sections, flanging and support brackets. Ensure that the ends of the insulating material are always firmly attached to the piping.

- Do not apply insulation where parts are too close together, as this will result in the insulation becoming squashed and losing some of its properties.

When carrying out particularly complicated installations on nickel steel, refer to our Technical Office.

TOOLS

A selection of good tools is essential for carrying out jobs to the highest standards.

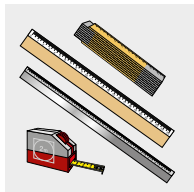

RIGID AND FLEXIBLE TAPE MEASURE
for measuring and tracing lines to cut.

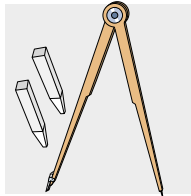

CHALK AND COMPASS
to draw reference lines for measurements and cuts.

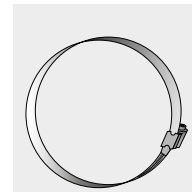

METAL BAND
to help cut insulating sheets at the end of large diameter pipes.

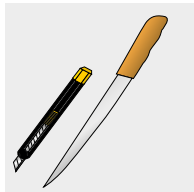

CUTTERS AND KNIVES
use both long and short bladed knives, with spare blades.

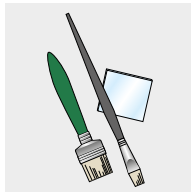

BRUSHES (VARIOUS) AND FLEXIBLE SPATULA
for spreading glue and painting.

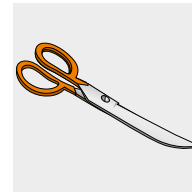

SCISSORS
to facilitate cutting insulating material.

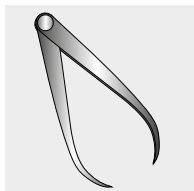

CALLIPER
for measuring the external diameter of surfaces to be insulated.

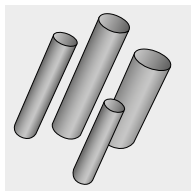

CIRCULAR PUNCHES
with a cutting edge to make holes in the insulation in a range of sizes.

PROCESSING OVERVIEW OF K-FLEX® SHEETS ON PIPES

K-FLEX® ST AND K-FLEX® ST PLUS SHEETS	OUTER DIAMETER DN			
	▼ DN 80 ▼	▼ DN 100 ▼	▼ DN 125 ▼	▼ DN 150 ▼
10 mm	•	•	•	•
13 mm	•	•	•	•
16 mm	•	•	•	•
19 mm	•	•	•	•
25 mm		•	•	•
32 mm			•	•
50 mm				•

• = possible application field of the sheet

K-FLEX® ST PLUS tubes have an increasing insulation thickness. If these tubes will be replaced by sheets, there is a possibility that the insulation thickness will not be sufficient.

K-FLEX® ECO, K-FLEX® S2 AND K-FLEX® SOLAR HT SHEETS	OUTER DIAMETER DN			
	▼ DN 80 ▼	▼ DN 100 ▼	▼ DN 125 ▼	▼ DN 150 ▼
6 mm	•	•	•	•
10 mm	•	•	•	•
13 mm	•	•	•	•
19 mm	•*	•*	•	•
25 mm			•	•
32 mm				•

• = possible application field of the sheet
*not for K-FLEX® S2

Please pay attention:

The temperature of the material has a major impact on the pressure during processing. High tensile stress must be avoided with K-FLEX® S2 products.

PRATICAL TIPS

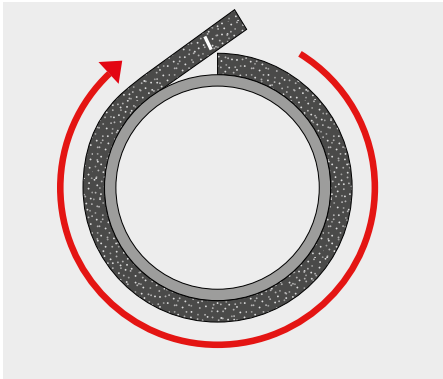

Many tasks encountered when insulating a system are repetitive. We have attempted to provide examples which can help bring optimum results straight away, saving time and effort.

MEASURING A CIRCUMFERENCE

The measurement is obtained by using a strip of K-FLEX® of the same thickness to be used as the insulation. This gives you the measurement of the circumference, including the thickness of the insulating material itself. Do not stretch the strip when encircling the pipe, as this will alter the measurement. Mark the strip with chalk where the two edges overlap.

GLUEING THE EDGES OF A TUBE CUT ALONG ITS LENGTH

To glue the edges, wrap the tube around a larger diameter pipe so that the edges do not overlap and apply the glue. Then slide the tubing over the pipe to be insulated, taking care to avoid the edges sticking before the tube is in place.

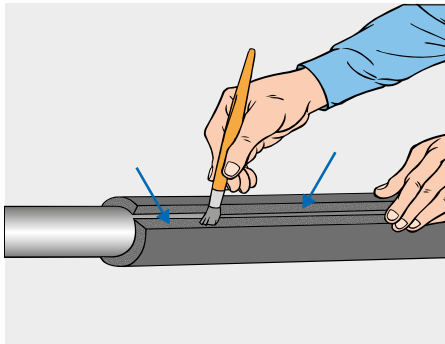

After spreading the glue, ensure that it has dried properly before attempting to stick the edges together. The best test is by touching the surface with your finger: if K-FLEX® glue no longer sticks to your finger forming threads, it is ready to be positioned.

USING OFF-CUTS



Off-cuts from K-FLEX® tubes and sheets can be re-used when filling in gaps, or where smaller quantities of material are required.

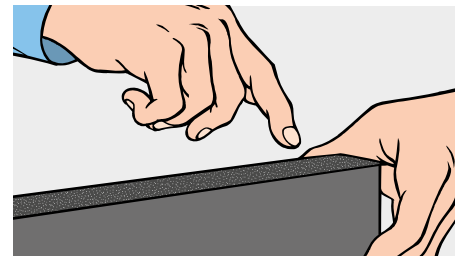
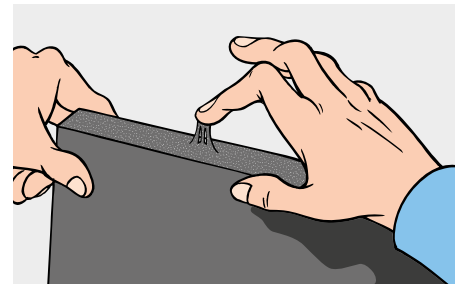

If the tube is not very long, or is not very thick, it can be rolled up and glued. This way, the tube can be quickly and easily applied to the pipe.

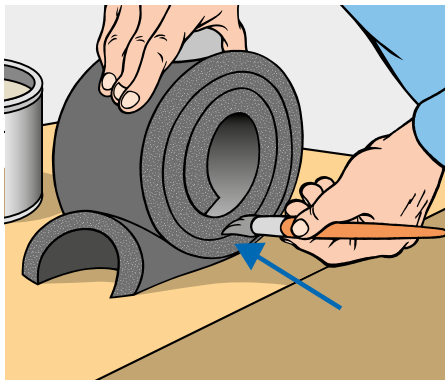

When attaching the two surfaces, press them together firmly with your fingers, starting at the far ends, then the centre and lastly along the intermediate points to avoid an irregular joint.

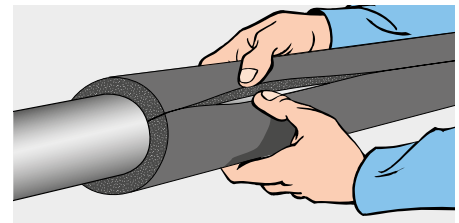

GLUEING THE EDGES OF A K-FLEX® SHEET

When insulating large diameter pipes, sheeting should be cut to fit and both edges glued. For the best results, a thin, even layer of K-FLEX® glue should be applied using a brush with short, hard bristles.

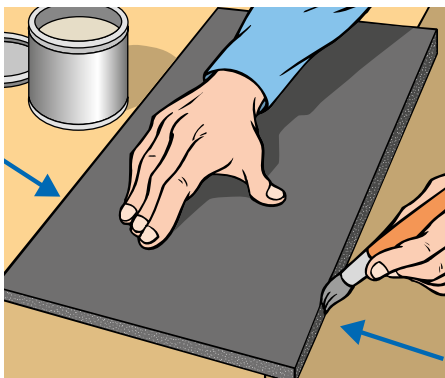

Use a straight-edged spatula to spread the glue over larger areas. If the whole of the surface is to be insulated, first apply the glue to the K-FLEX® sheet, then to the surface it is to be stuck to. When the glue has dried sufficiently, apply the sheet to the surface.



INSULATING PIPES UP TO 125 MM IN DIAMETER

Around 80% of piping used in civilian buildings can be insulated before fitting. This simplifies the task and saves time, taking advantage of the wide range of applications offered by an elastomeric product like K-FLEX®.

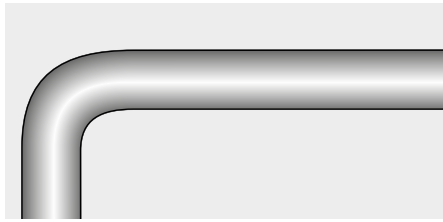

Bring the edges of the tubing to be glued together and press tightly.

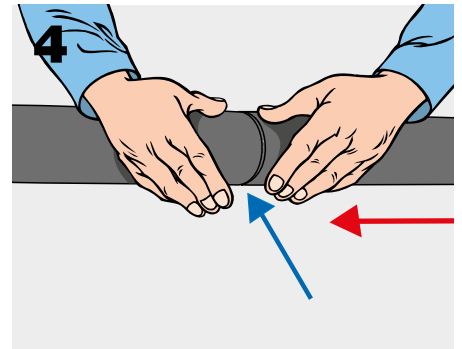

PIPES TO BE FITTED

Slide the K-FLEX® tube directly over the pipe from one end. Do not force the tube while fitting as this will deform the material. Instead push it smoothly without exercising undue pressure.

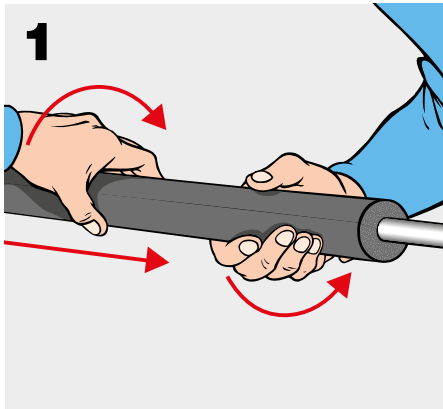

If the underlying pipe has to be brazed, free an area 25/30 cms long between the part to be soldered and the edge of the tubing. Once the pipe has cooled, the insulation can be completed.

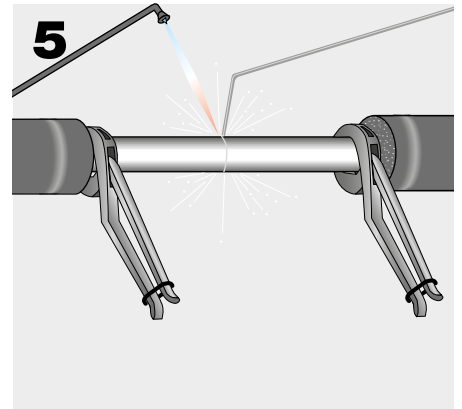

When a section of tubing has been positioned satisfactorily, stick at least one extremity to the pipe with K-FLEX® glue.

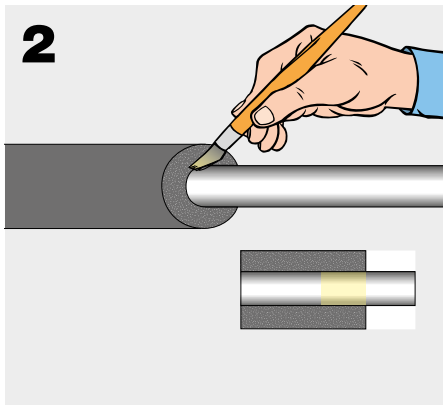

Test for strength around critical stress points in the pipes, such as elbow joints, branches or stopcocks, before proceeding to glue the tubing around them.

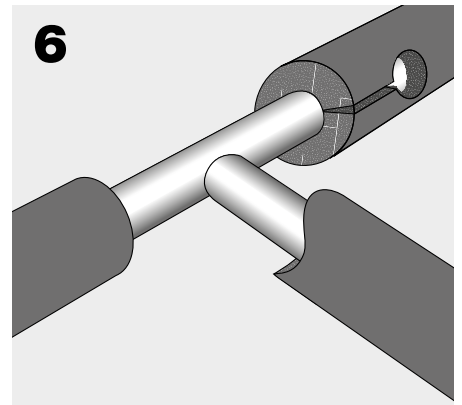

Apply glue to the edge of the tubing already in place and the edge of the next section of tubing to be positioned.

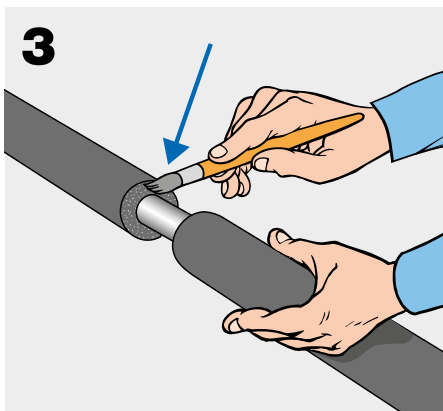

FITTED PIPES

If the piping has already been installed, the K-FLEX® tubing must be cut along its length to fit it.

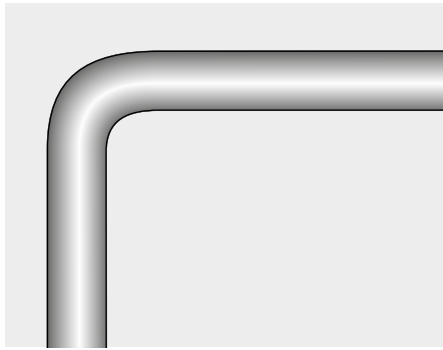

Use only the sharpest knife for cutting - this makes the subsequent glueing far easier.

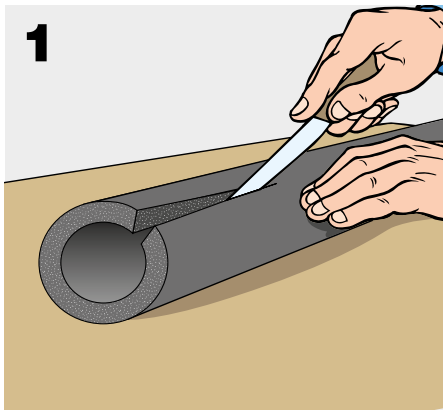

Position the tube so that the edges are separated, and apply an even layer of K-FLEX® glue.

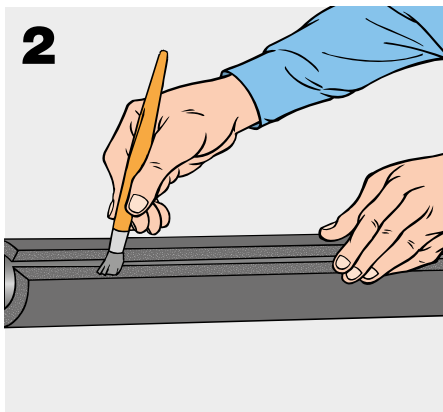

Once the glue has dried, reseal the tube, pressing the edges firmly together.

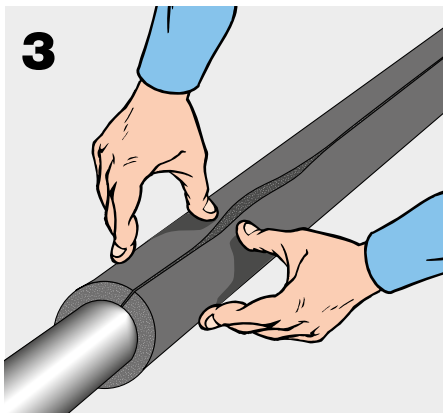

When making a joint between two lengths of tubing, cut the insert a little longer than necessary (a couple of millimetres). If the insert is not long enough, the insulating properties in that area will be reduced.

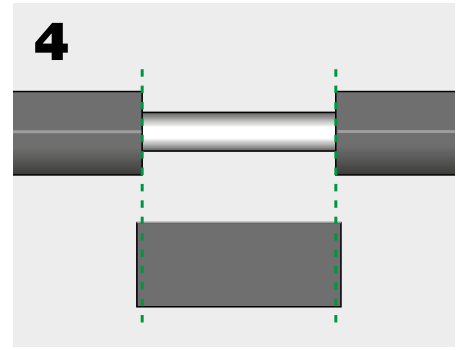

Cut the insert along its length and glue into place.

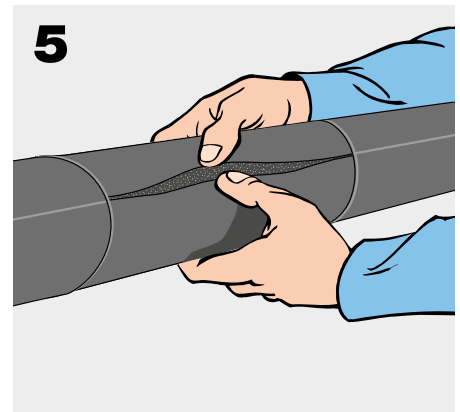

SELF-ADHESIVE INSULATION TUBING

Flexible K-FLEX® tubing for insulating fitted pipes.

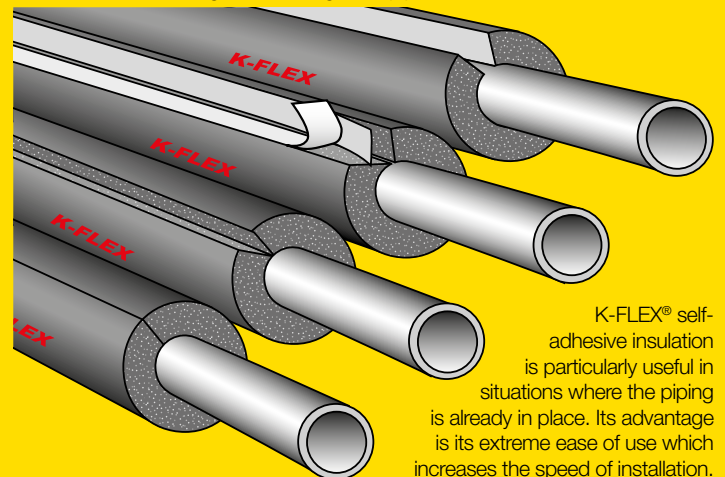

K-FLEX® self-adhesive insulation is particularly useful in situations where the piping is already in place. Its advantage is its extreme ease of use which increases the speed of installation. K-FLEX® self-adhesive tubing can even be attached to bends in pipes with little effort. Carefully read the installation suggestions that follow.

90° ELBOW FITTINGS

An elbow is a pipe with a 90° bend, either curved or fitted. The attachment points themselves may present a different diameter to the pipes either side.

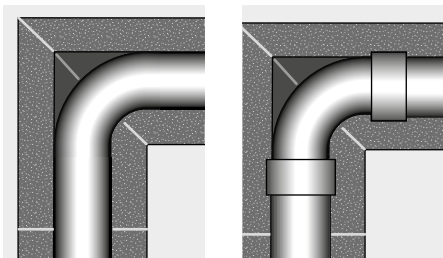

... then glue the two sections..



INSULATING AN ELBOW FITTING with tubes of the same diameter

Cut a K-FLEX® tube to the right length to cover the elbow. Cut it in the middle at an angle of 45°. Use the K-FLEX® cutting board as a template for the angle of the cut. A long-bladed knife is required.

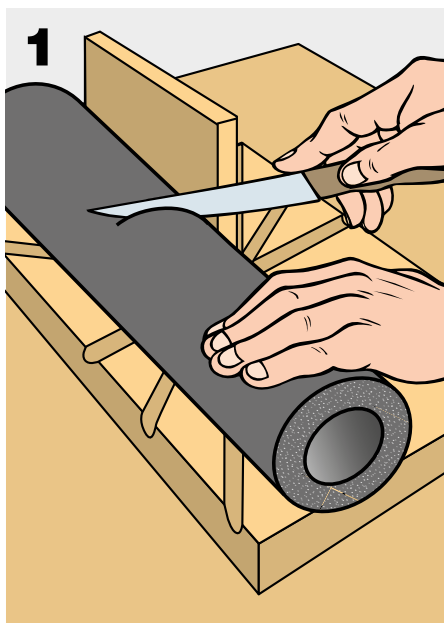

After letting the glue dry, cut the rightangled section along its length on the inside.

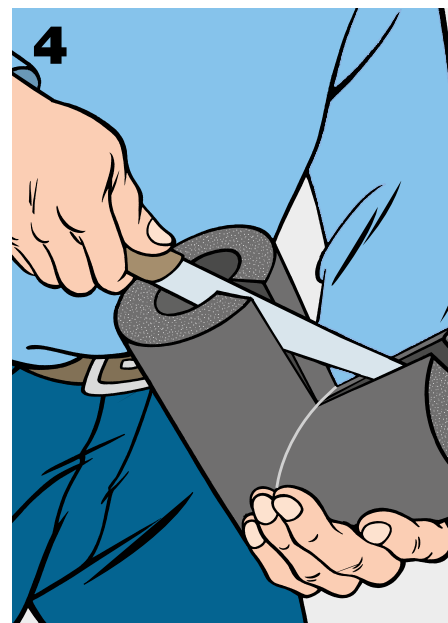

Twist one of the pieces of tube until you form a 90° angle...

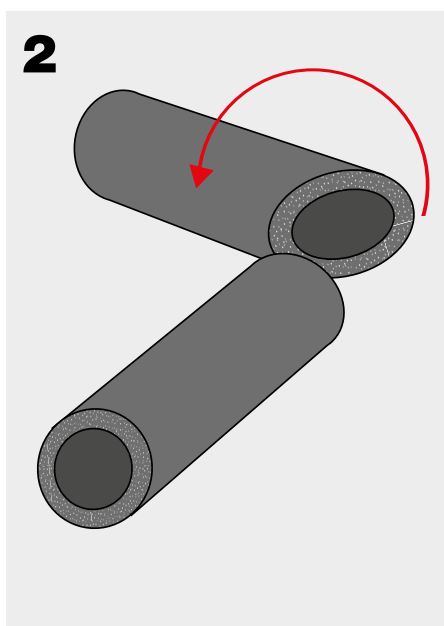

Position it on the pipe and glue the two edges.

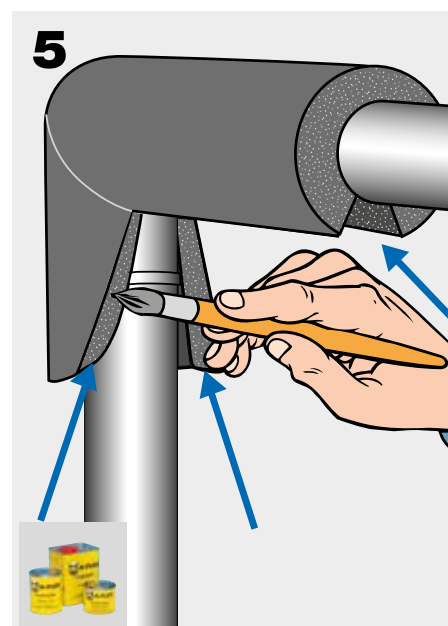

Press the edges together to seal.

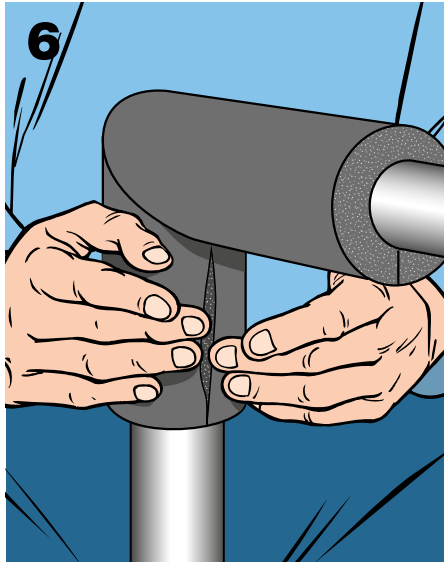

Carefully glue the edges of the elbow section to the straight tubes to be positioned either side.

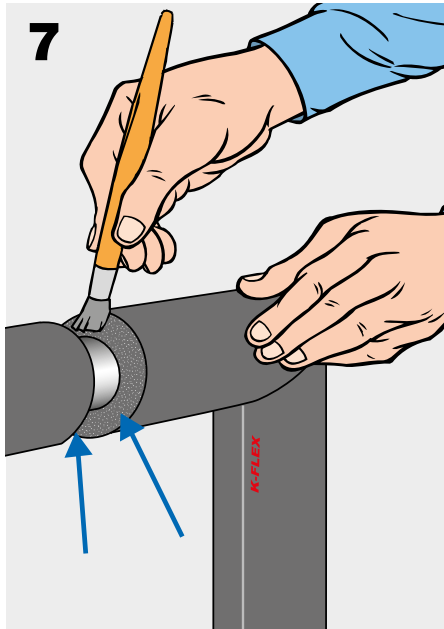

If the straight sections have already been glued into place, the right-angled section will have to be accurately measured to fit.

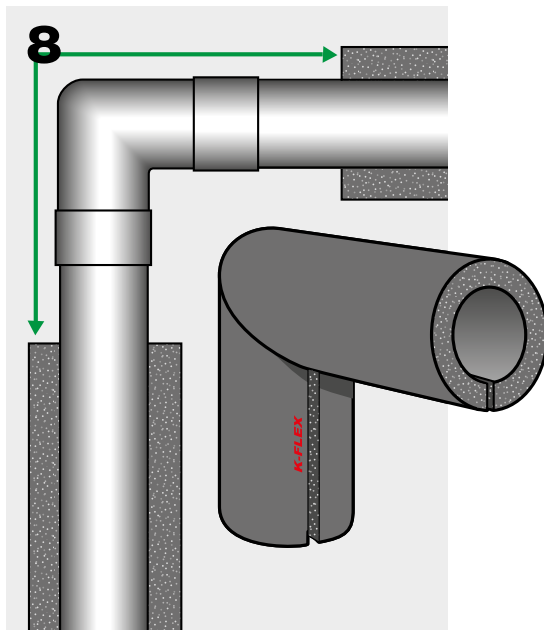

INSULATING AN ELBOW with tubing of different diameters

Should the elbow fitting be substantially different in size to the pipes either side, the latter should be insulated first. The angle of the cut. A long-bladed knife is required.

Then find a section of tubing with an internal diameter that is the same as the external diameter of the smaller ones either side...

... and cut the right-angled joint so that it overlaps the ends. (see illustration).

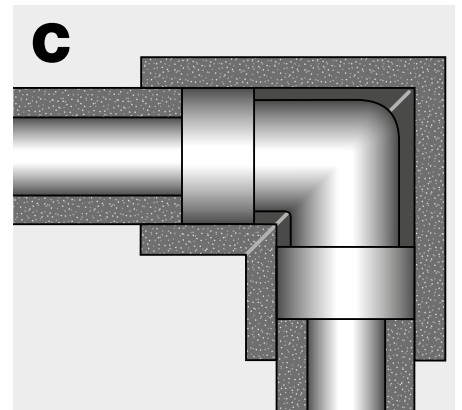
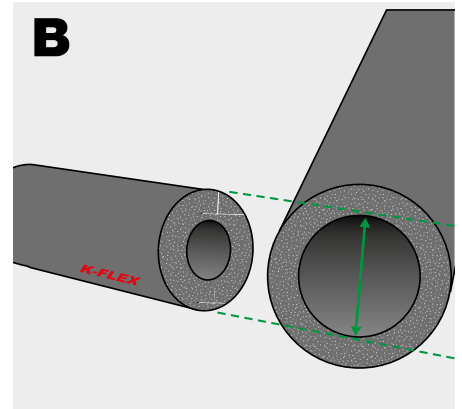
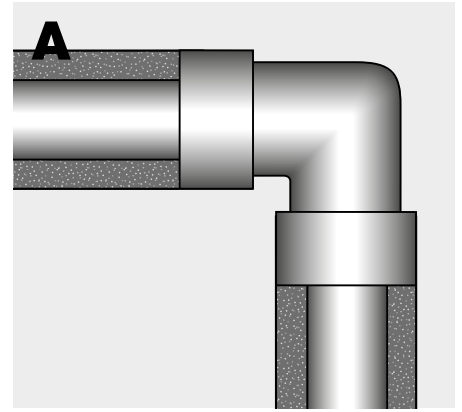

SEGMENTED INSULATION OF AN ELBOW FITTING with tubing of the same diameter

An elbow can also be insulated using jointed sections of tubing. This requires two angled cuts to be made.

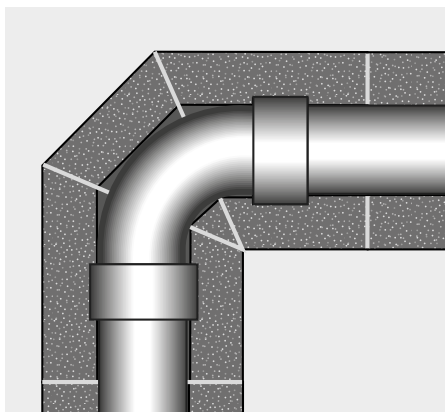

Cut a piece of K-FLEX® tubing to the right length to cover the elbow.

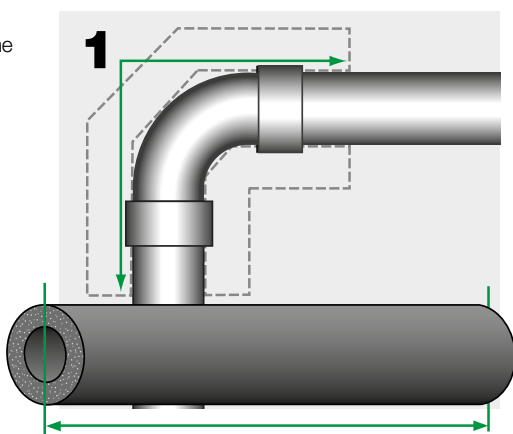

Calculate the tube's external diameter and trace two parallel lines this far apart in the middle. Draw a line between the two to mark the centre line. Then make two marks (C and D) either side of the centre line one centimeter from it, and draw two lines running A to C, and B to D (see diagram).

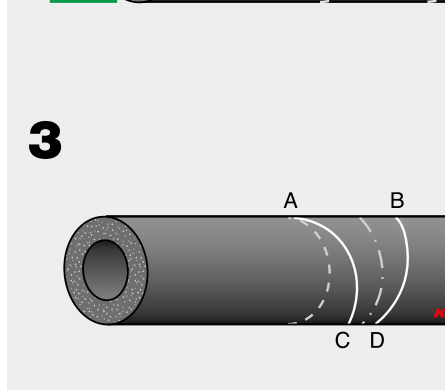
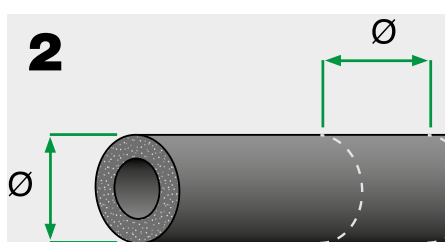

Cut along lines AC and BD.

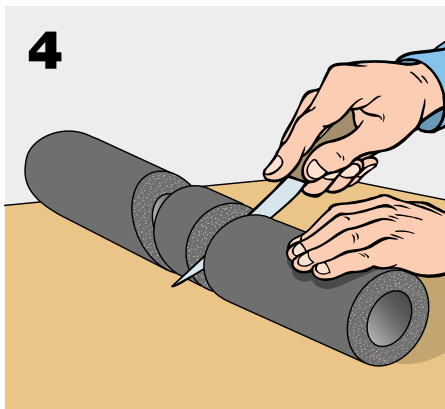

Rotate the two ends to obtain a 90° angle section.

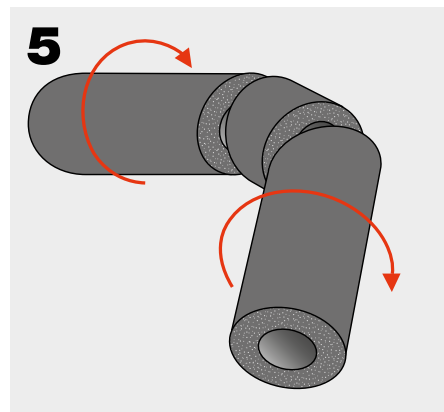

Glue the three sections together.

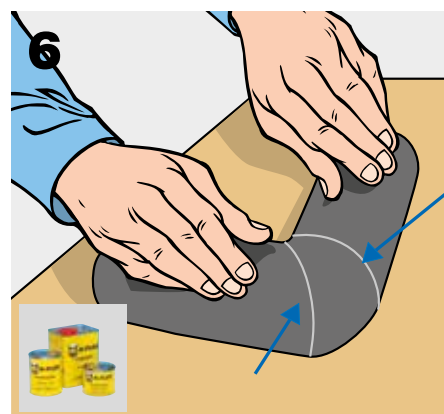

Cut the segmented elbow section along its length on the inside surface only.



Slide the elbow section over the pipe and carefully glue the edges together.

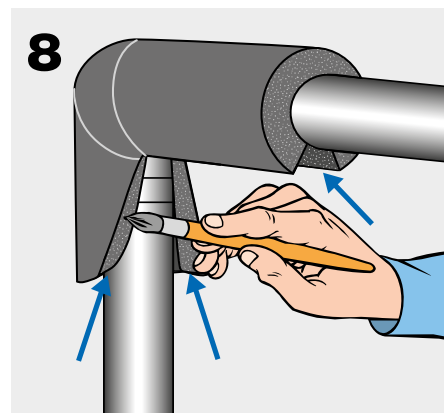

After completing this stage, fix the elbow section to the tubing either side with K-FLEX® glue.

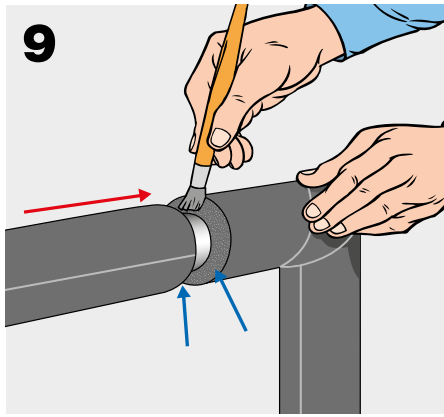

If the adjacent tubes are already in place, the length of the elbow section will have to be accurately measured.

Cut the length of tube required a little longer than it should be and trim it if necessary.

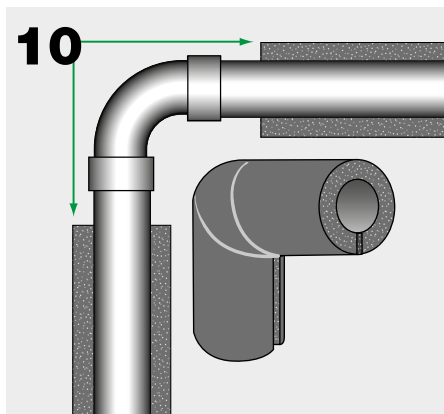

SEGMENTED INSULATION OF AN ELBOW FITTING with tubing of different diameters

If the pipes either side of the elbow are smaller in diameter, first insulate the straight pipe sections.

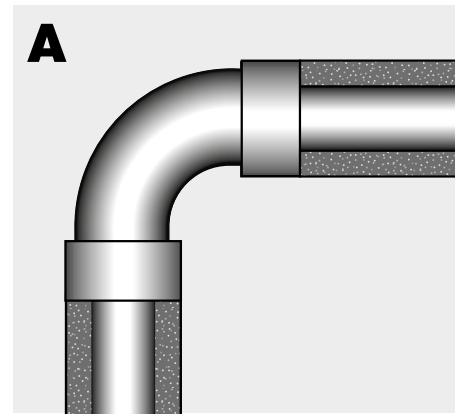

Then find a tube with an internal diameter the same as the external diameter of the neighbouring insulation.

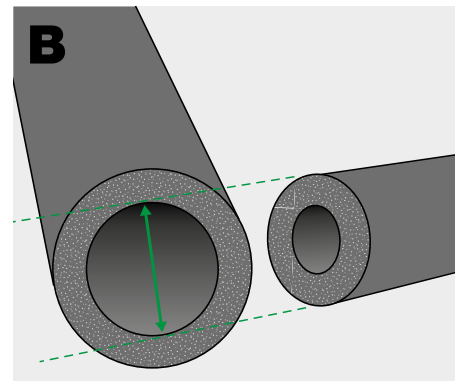

In this way, the segmented elbow section will overlap the edges of the insulation either side.

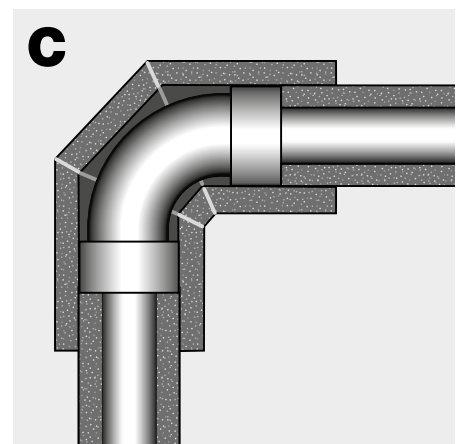

“T-FITTINGS”

The T-fitting can be insulated with or without the tubing either side having been applied. The latter is the simplest method, and is thus the one illustrated here. There are two methods of insulating a T-fitting: by dovetailing two tubes with a 90° cut-out, or by punching a circular hole smaller in diameter, first insulate the straight pipe sections.

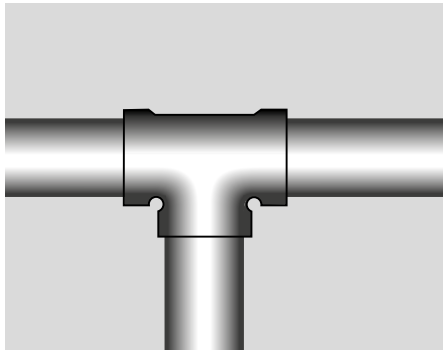

Glue the cut edges and stick them together in the shape of a “T”.

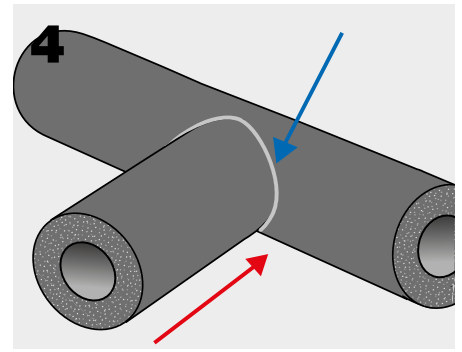

INSULATING A T-FITTING with a 90° cut-out

Cut a section of K-FLEX® tubing into a third and two-thirds of its original length respectively. The overall length should obviously be sufficient to cover the three pipes leading from the fitting.

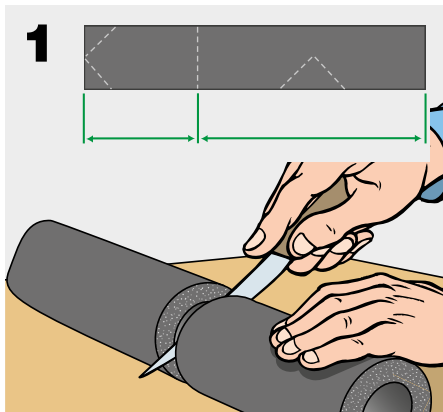

Cut the lower half of the “T” along its entire length so that it fits snugly over the T-junction. Then once more apply a layer of K-FLEX® glue to the edges.



Using the K-FLEX® cutting board, cut the end of the shorter tube twice at an angle of 45°.

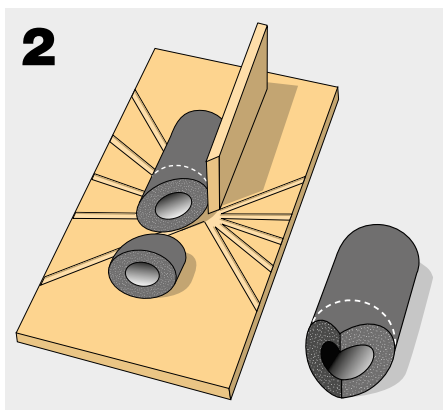

Stick the insulation to the T-junction. Then the three straight tube sections can be attached and glued together.

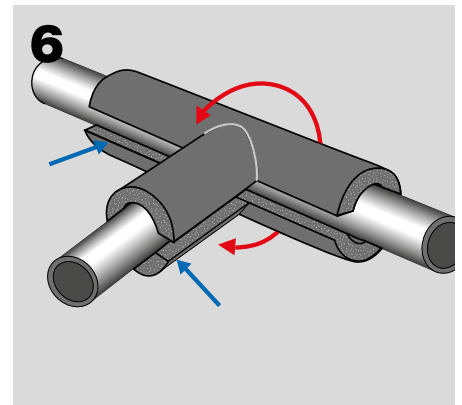

Taking the second, longer segment, make two 45° cuts in the middle. The cut-away section should have the same cross-section as the outside of the tube so that the two sections (see 2) dovetail perfectly.

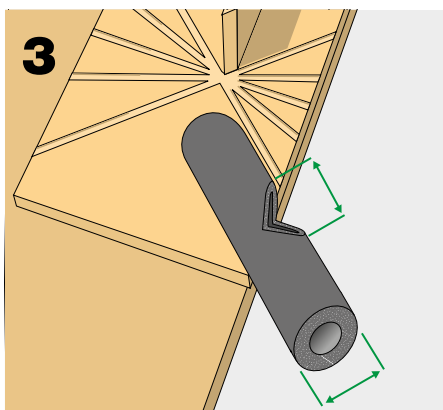

Where the adjacent pipes are smaller in diameter than the T-junction, these can be insulated before the T-junction itself.

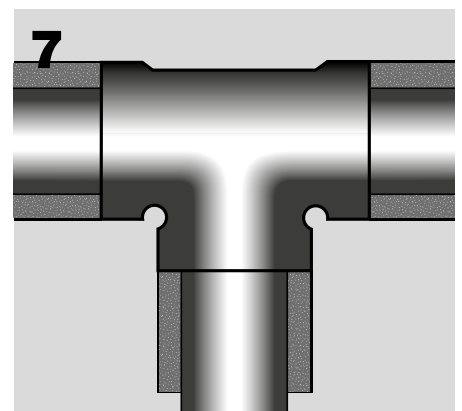

Make a T-section joint as before (see pages 24-25), using, however, a tube with an internal cross-section the same as the external diameter of the neighbouring tubes.

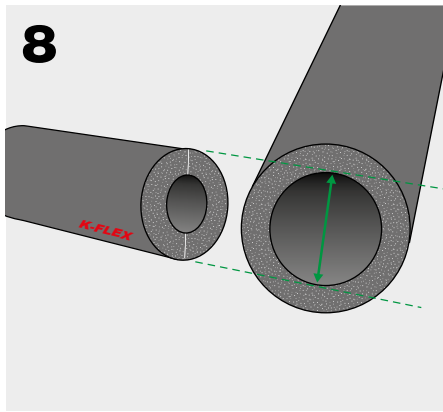

INSULATING A T-FITTING with a round insert

Using a punch or metal tube with a cutting edge of the same diameter as the tubing, make a hole in the insulating tubing at the point where the "T" is to be formed.

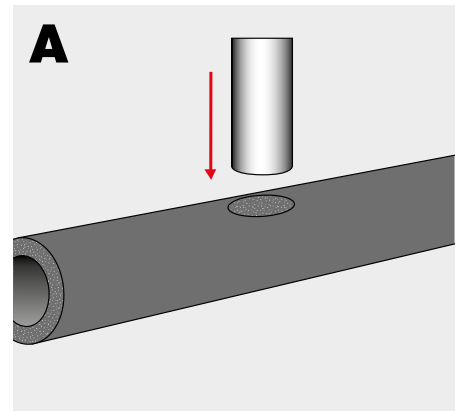

Apply the joint which should overlap the edges of the other insulating tubes. Carefully glue and stick the edges and those surfaces in contact with the other tubes.

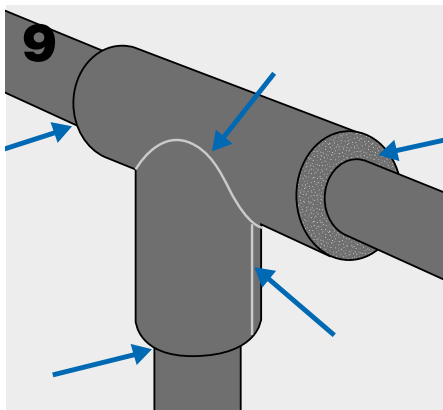

Cut the tube along its length and slide it onto the pipe so that the hole is positioned around the third pipe. Then stick the edges back together.

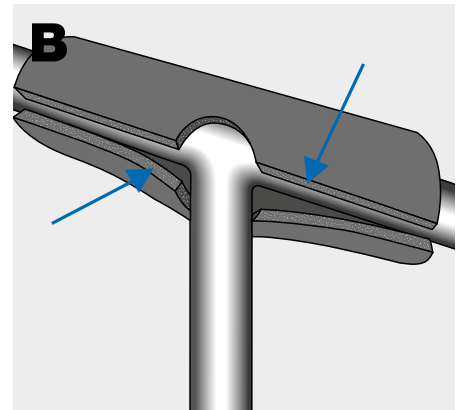

The joint for the lower branch is created by cutting a U-shaped section from a second piece of tubing.

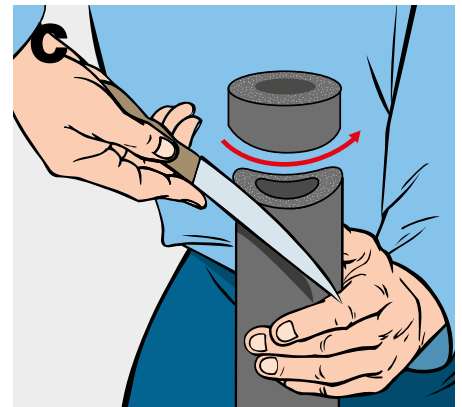

Align the lower tube so that it fits the hole in the upper section snugly and glue the whole together.

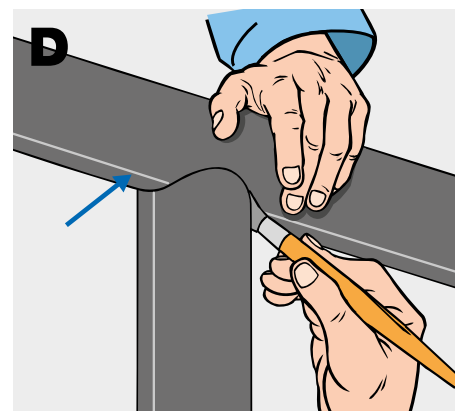

VALVES

These can be insulated in a number of ways, depending on the type of valve.

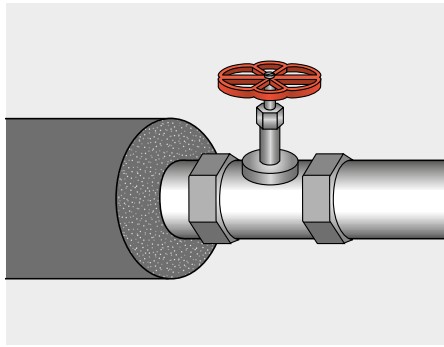

Small valve stem

From the edge of the K-FLEX pipe, make a cut long enough to house the valve and punch a hole to fit the stem.

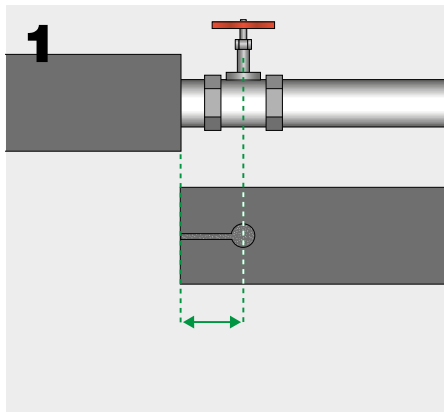

Fit the tube snugly round the valve and glue the edges together with K-FLEX® glue. Then attach the edges of the insulating tubing to the next section.

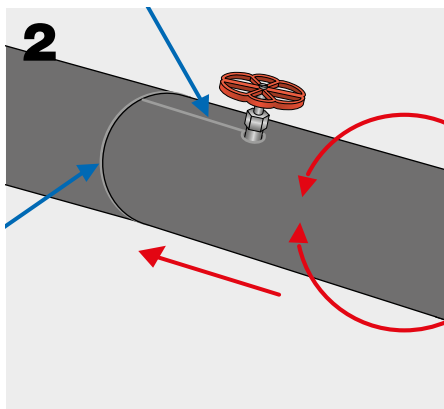

Large diameter valve stem

Insulate the pipe right up to the valve on both sides. Wrap K-FLEX® self-adhesive insulating tape around the base of the valve.

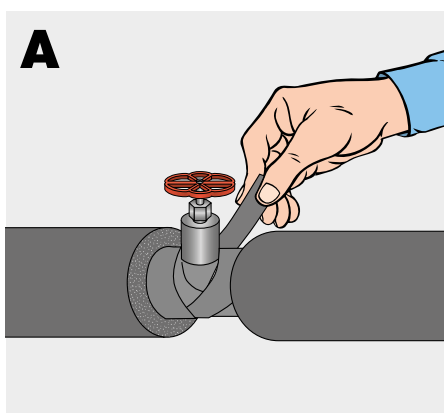

Cut a section of K-FLEX® tubing as long as the circumference of the tubing already in place, and cut it along its length.

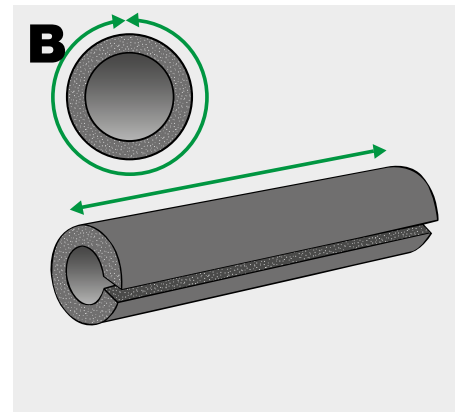

Flatten the tube out and make a longitudinal cut with a hole punched at its end to take the valve housing.

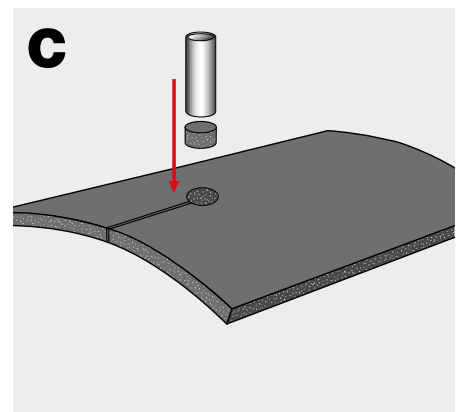

Position this around the valve so that the sleeve overlaps the ends of the two underlying tubes.

If necessary, remove the valve if this gets in the way.

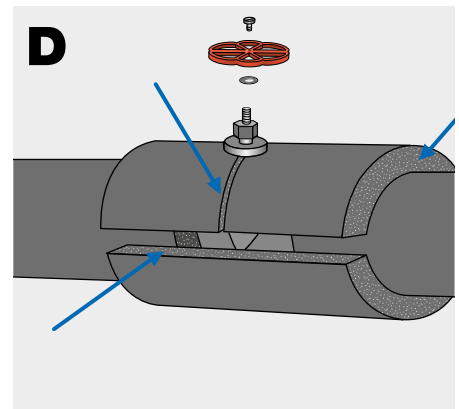

Glue and stick the sleeve's edges. If necessary, the stem of the valve can also be insulated by applying a ring-shaped section from one of the off-cuts.

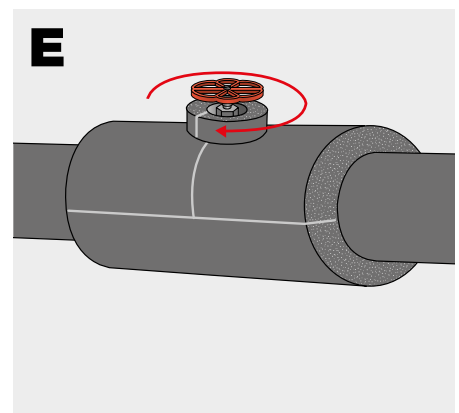

SPECIAL APPLICATIONS

INSULATING A REDUCER

When insulating a reducer that connects two pipes of different diameters, leave sufficient space between the sections of insulating tubing either side of it.

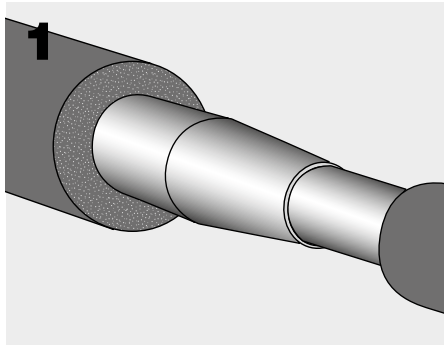

Take a piece of K-FLEX® the same diameter as the larger of the two pipes, and cut it slightly longer than the space left between the two sections of tubing already in place.

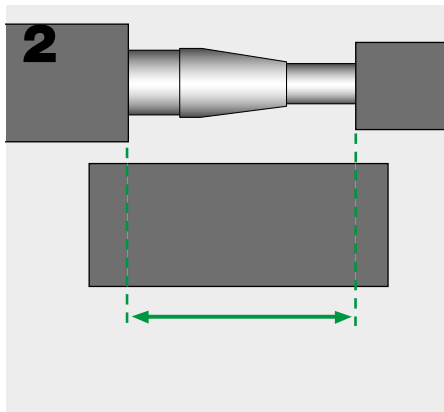

At one end, cut out two equally-sized wedges opposite each other to create a reduction in circumference that will fit the smaller tube.

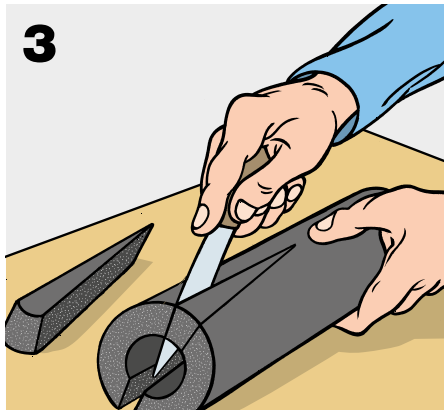

Glue the edges of the cut-outs together so that the diameter of the tubing reduces.

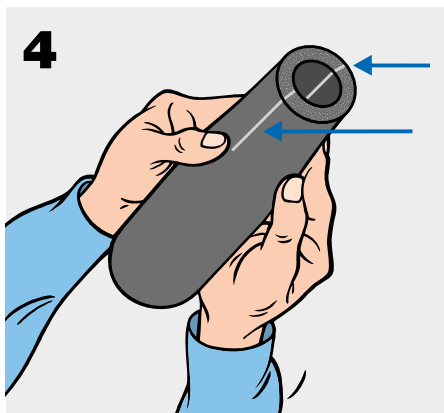

Trim the smaller end to the length at which its diameter matches that of the smaller tube.

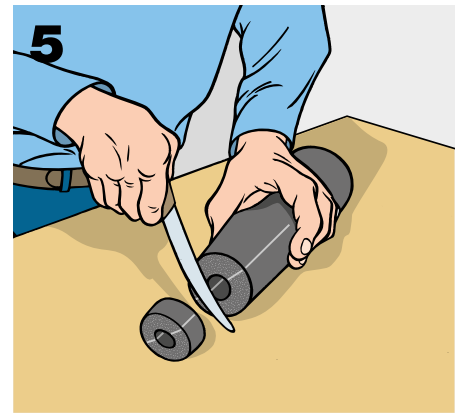

Shorten the other end, too, so that the coupling can be inserted neatly into the space left between the two existing sections.

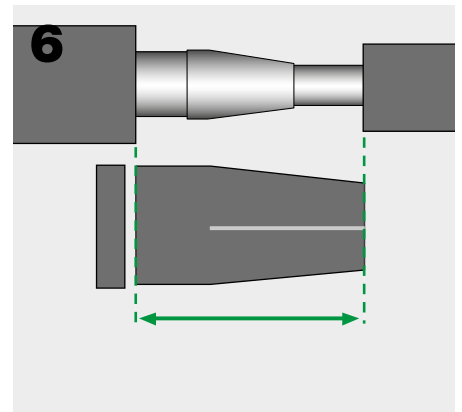

Cut the coupling along its length to install it on the pipe.

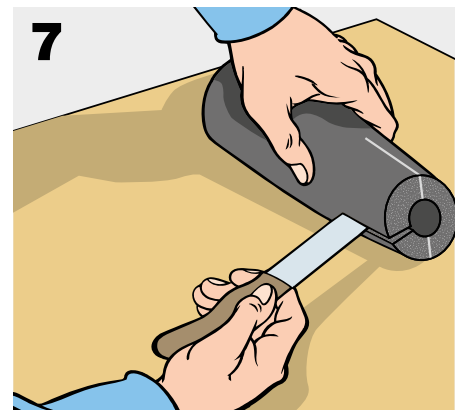

After positioning it on the pipe, glue the edges of the lengthwise cut with K-FLEX® glue and bond the edges of the sleeving to the other two sections of tubing.

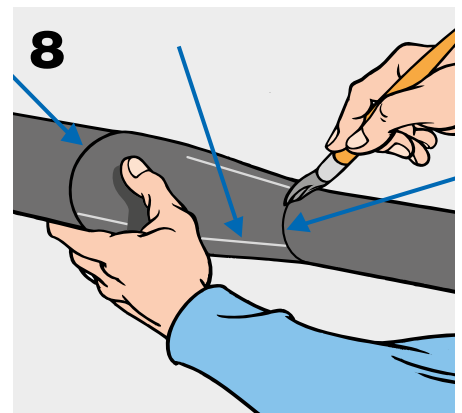

INSULATION FOR PIPE SUPPORT

To grant perfect insulation continuity through areas interested by suspension devices K-FLEX® suggest to installers the use of a specific support designed for the function with a wide range of diameters in order to allow easy and efficient installation.

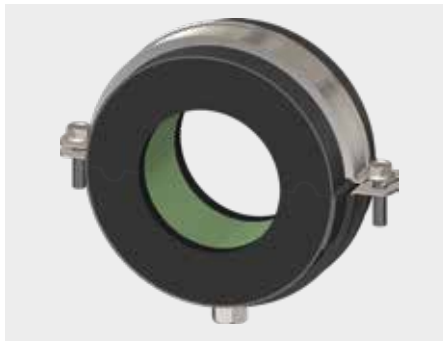

1



Open the two halves of the support and place it around the pipe in correspondence with the suspension point.

2



Glue support edges with K-FLEX® glue and join the two halves on the pipes.

3

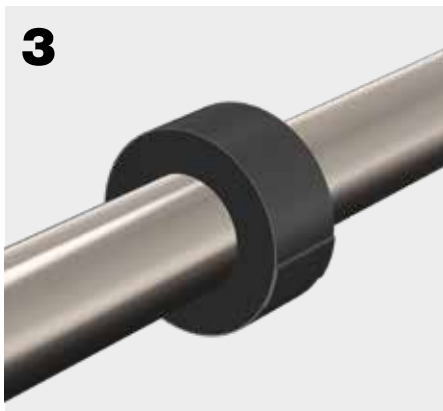

Seal the support by overlapping the self adhesive band.

Fix clamp to suspension system.

4



Join after gluing the edges of K-FLEX® pipes with the support.

5



END CAPS

Using the correct size punch, make a plug from a spare piece of K-FLEX® sheeting. Glue all the facing surfaces and insert in the open end of the insulating tube.

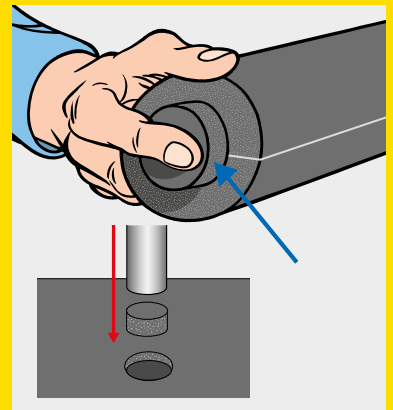

INSULATING "Y" BRANCHES

a) Cut a section of K-FLEX® tubing to the right length.

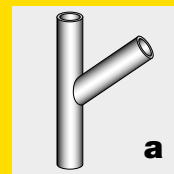

b) Use a punch to pierce a hole at the angle required.

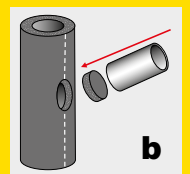

c) Cut the tube along its length, position it on the "Y" branch and glue the edges together with K-FLEX® glue.

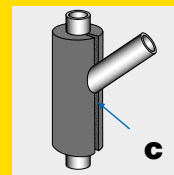

d) Using a second piece of tubing, cut out a U-shaped indent at the correct angle and cut the tube along one side to attach it to the branch.

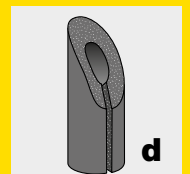

e) Fit the tubing on the "Y" branch and glue it in place with K-FLEX® glue.

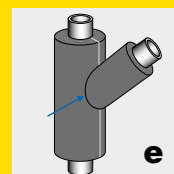

SEGMENTED CURVES

When it is not possible to slide the tubing around bends in the piping, a segmented curve can be made.

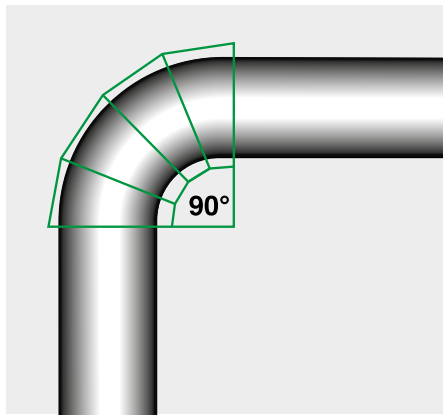

Take a section of tubing of the correct diameter and cut it either three or five times at the same angle at 90° to each other. Use the K-FLEX® cutting board to ensure accurate results.

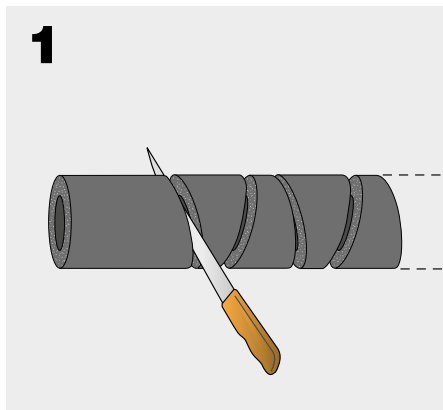

Twist every other segment thus obtained through 180° and assemble them together to get a curved section.

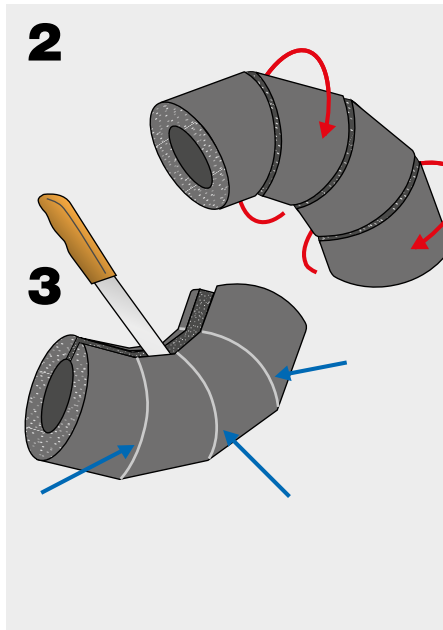

After sticking all the sections together with K-FLEX® glue to complete the bend, make a lengthwise cut in the lower half so that it can be fixed onto the piping.

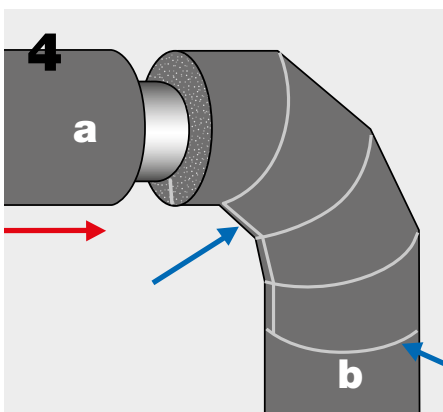

Position the insulating tubing over the bend in the pipe and bond the edges of the lengthwise cut with K-FLEX® glue. The side sections (a-b) must be positioned so that they match the extremities of the tubing on either side.

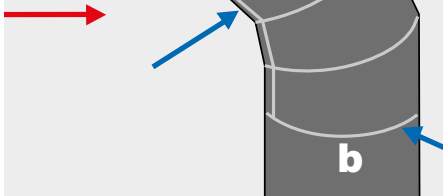

ELBOW FITTINGS (over 90°)

This is a joint created by welding two sections of pipe at an angle over 90°.

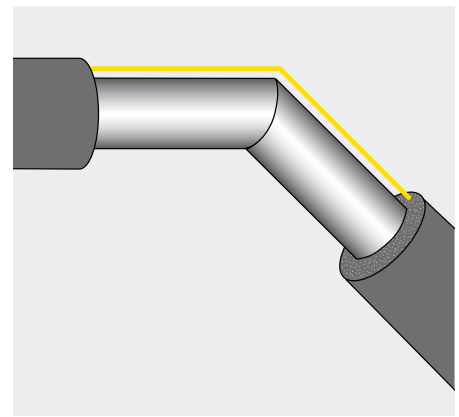

1) The adjacent tubes would normally already be in place when calculating the length of tubing necessary to complete the insulation of the joint. We recommend cutting the central section slightly longer than strictly necessary so that it can be trimmed down to size when fitting. Measure the radius of the external circumference and draw two parallel lines that far apart in the middle. Draw a line at an angle between points A and B.

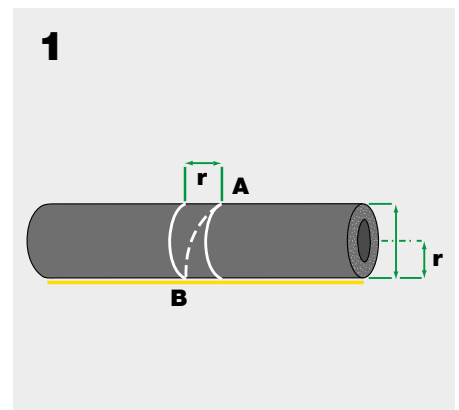

2) Cut along this line and rotate one of the sections until the required angle is obtained. Glue the two parts together with K-FLEX® glue.

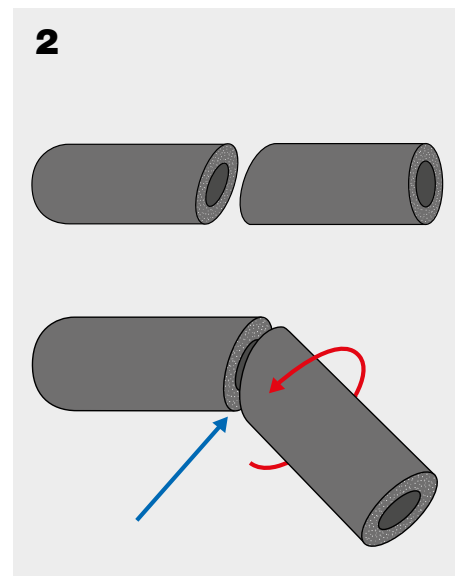

3) Cut along the inner surface of the joint.

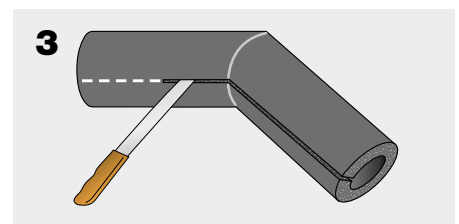

4) Trim the joint to fit between the two adjacent tubes and then glue all the edges together.

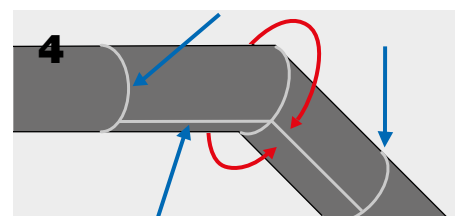

INSULATING PIPING OVER 125 MM IN DIAMETER

INSULATING A STRAIGHT PIPE

Wrap a strip of K-FLEX® of the same thickness as that to be used around the pipe to be insulated and measure the exact length required.

Mark out the length required on a K-FLEX® sheet.

Cut carefully along the line.

To ensure accurate results, use a metal ruler.

Apply an even layer of K-FLEX® glue along each edge and allow to dry.

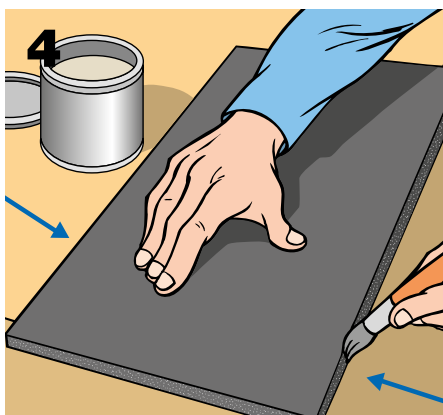
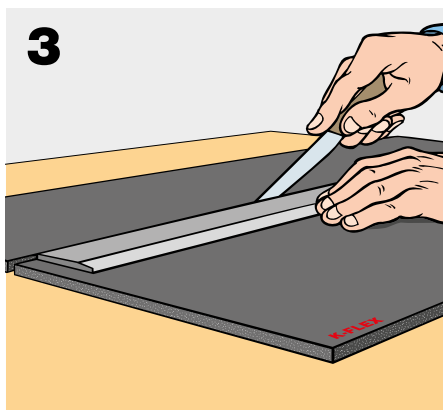
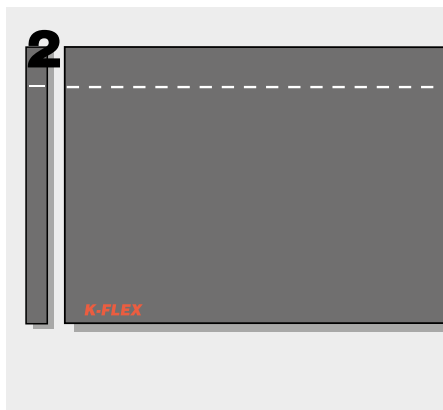
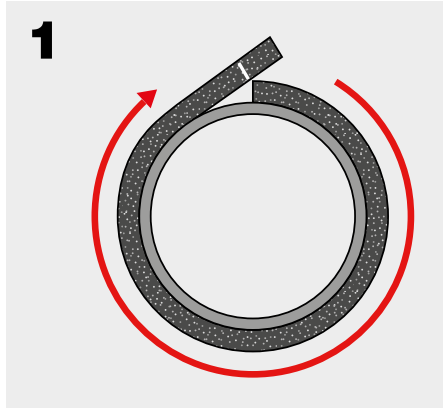

Wrap the insulation sheet around the pipe and press the glued edges together starting at the ends, then the center and then working along the rest of the length.

Glue the insulating sheeting to the subsequent sections along the length of the pipe.

If the tubing thus created is not correctly lined up, push one against the other slipping the brush in the gap and twist until they are aligned.

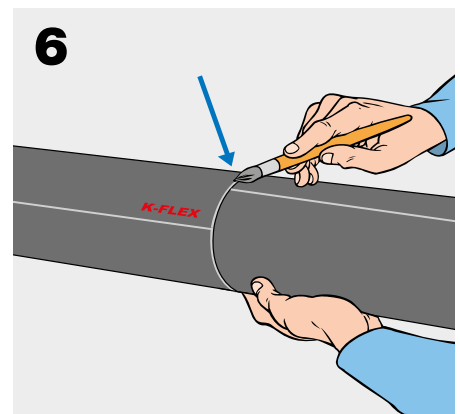
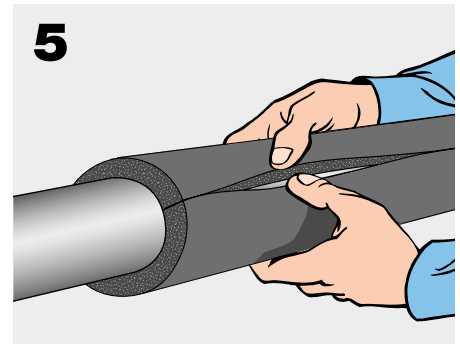

MULTY-LAYER INSULATION

If it is necessary to apply more than one layer of K-FLEX®, one sheet can be stuck on top of another.

Contact our Technical Office if you have to insulate piping transporting fluids below -40° C.

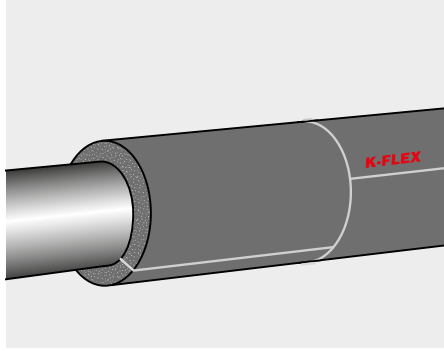

Clean the surface of the first layer of insulation.

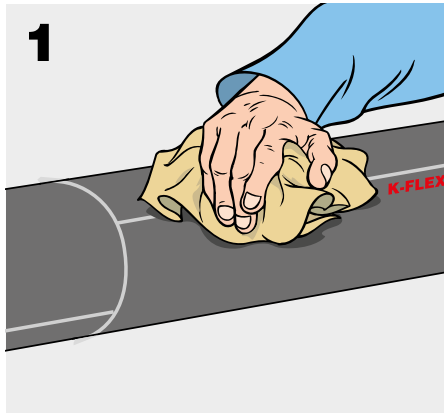

Measure the overall diameter with the first sheet in place.

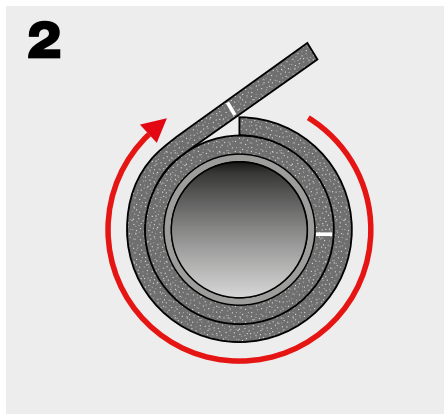

Cut out the second sheet to the size required.

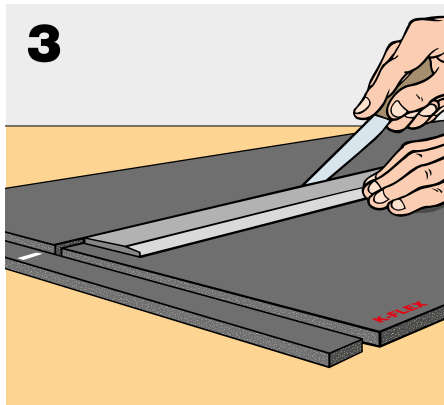

Glue the edges of the sheet to be fitted. Do not stick the two layers together, as the individual sheets may be subject to different degrees of expansion or contraction when the plant is operational.

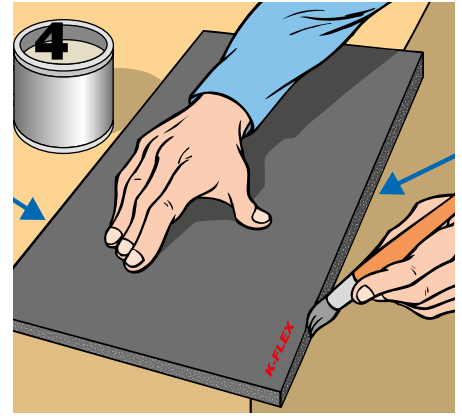

Wrap the insulation sheet around the tubing, ensuring that the seam does not overlap that of the underlying insulation.

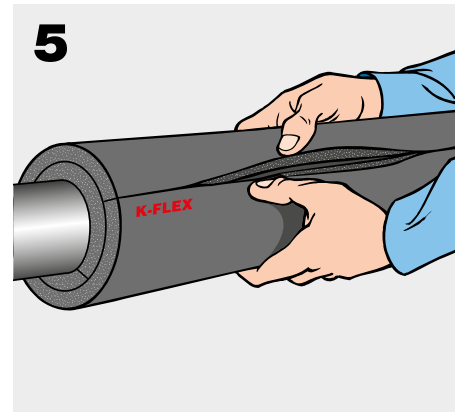

Adjacent sections of insulation should be glued at their respective ends.

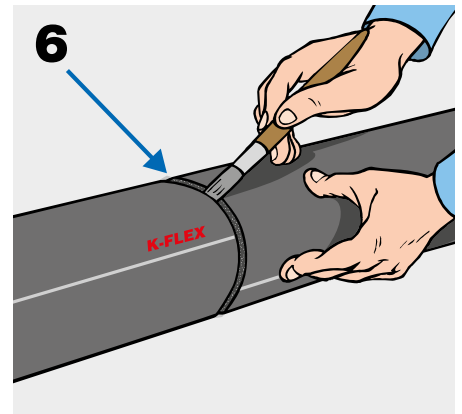

When installing the second layer, make sure that the seams do not overlap those underneath (see diagram). This ensures that, when the plant is operational, maximum insulating properties are maintained as the materials expand or contract.

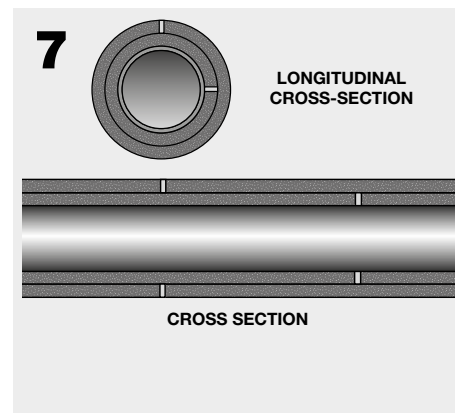

ELBOWS

To insulate an elbow in a large-diameter pipe, calculate its radius and mark it out on a K-FLEX® sheet.

For diameters over 500mm, "fishtails" elbow drawing is suggested.

First of all, measure the internal radius of the curve using a ruler and a rule lying perpendicular to it, as shown in the diagram.

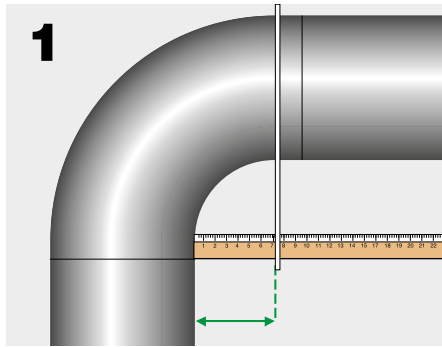

Using a compass, mark the out-line of the internal radius on the K-FLEX® sheeting, using the corner of the square marked out on the insulating material as the axis.

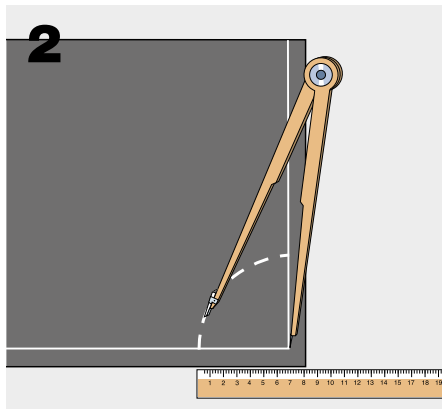

Measure the exact circumference of the pipe using a strip of K-FLEX® of the correct thickness (do not stretch the strip).

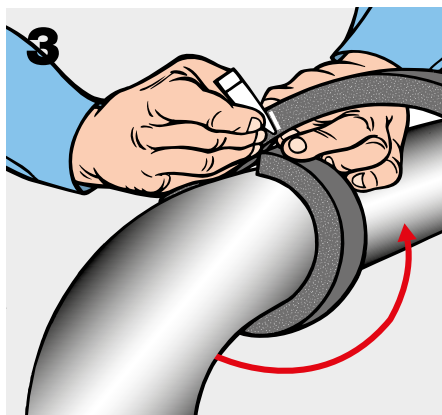

Divide the circumference by two, and mark the middle of the strip accordingly.

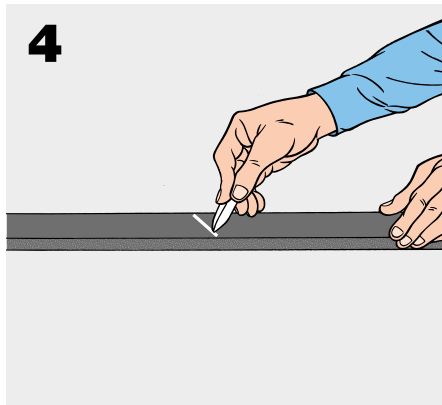

Add the outer radius to the measurement of the inner radius and, using the same axis, draw a semicircle onto the sheet with the compass.

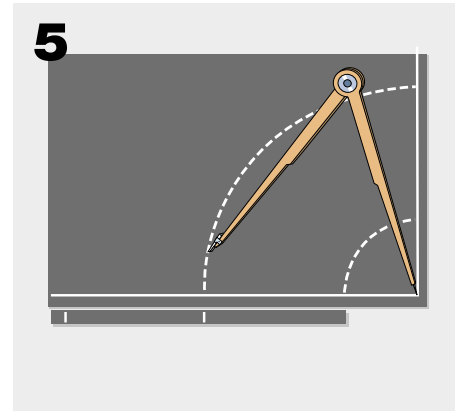

Cut the sheeting accurately along the arc of the circle.



If imperfections are found along the cut edges, smooth them slightly to assure a more precise match.

Place the section obtained on the reverse side of another sheet and use it as a template to cut out a second, mirror image section.

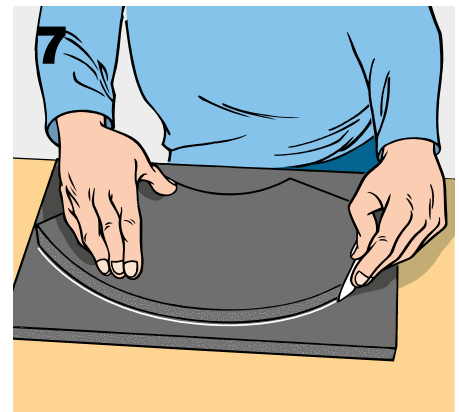

Holding the two sections together with the smooth surface on the outside, apply glue to the outer edges.

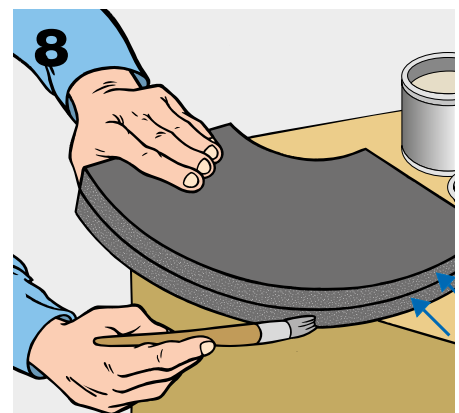

Allow the glue to dry and stick the edges together, starting from the two extremities.

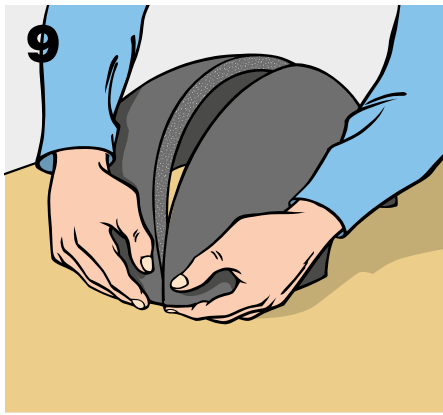

Apply pressure in the center, too.

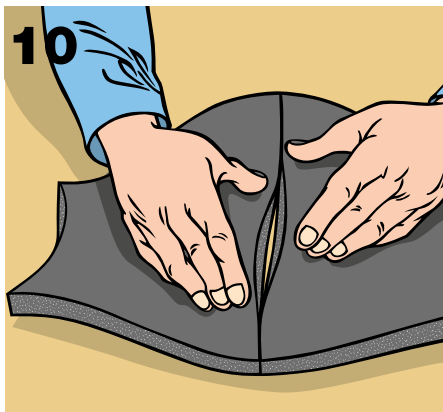

Make sure that the two sections have bonded securely on the inside as well, pressing with your fingers along the joint.



Next spread the glue along the inside edges and leave to dry.

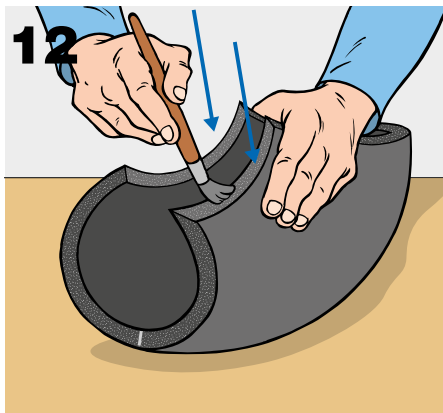

Wrap the K-FLEX® insulation around the pipe and press the edges tightly together.

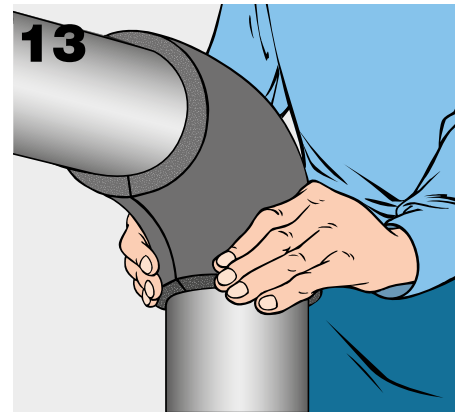

Use the metal band as a guide to trim the extremities ...

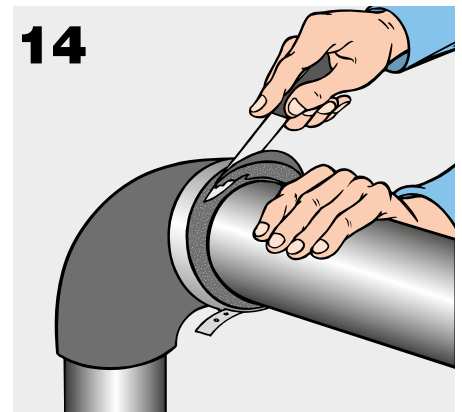

... so that they butt precisely up against the tubing to be fitted either side.

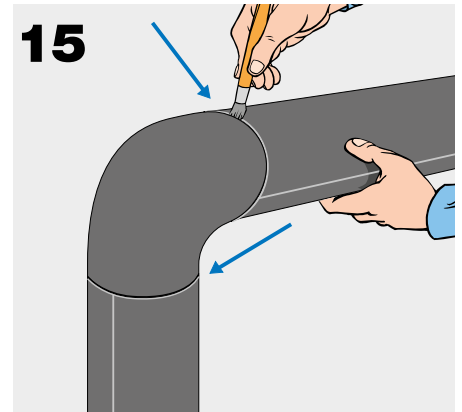

INSULATING 90° BENDS WITH K 90

K-FLEX® produces prefabricated bends in K-FLEX®, K 90 bends, in various thicknesses and diameters in order to save labor time and eliminate waste material.

K 90 bends are mechanically modeled on computerized schemes and their precision gives an excellent fit.

Measure the diameter of the piping to be insulated and choose the appropriate K 90 bend at a K-FLEX® retailer's.

Some examples of product correspondence:

Ø	THICKNESS 19	THICKNESS 25
48	19 x 48	25 x 48
114	19 x 114	25 x 114

Application is extremely easy. Use K-FLEX® glue inside edges of the K 90 bend. Two pieces elbow is showed as installation example. A segmented elbow may be provided instead of the two pieces one.

Position the K 90 piece on the bend to be lagged.

Bond the glued edges together by applying pressure.

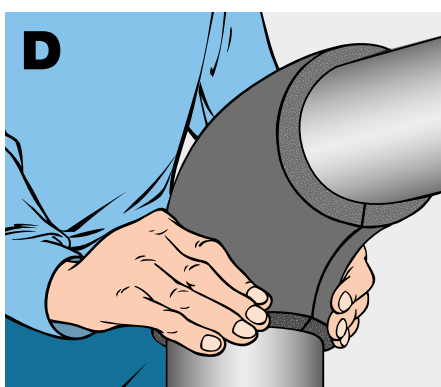
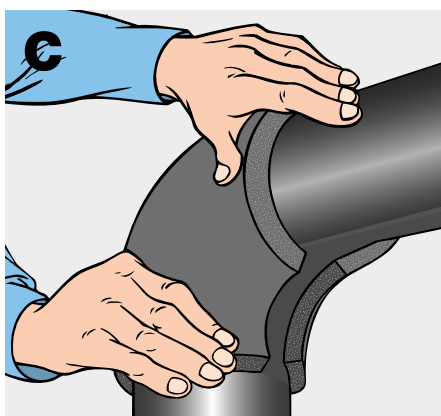
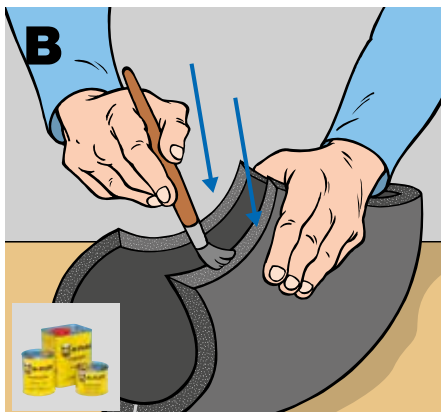
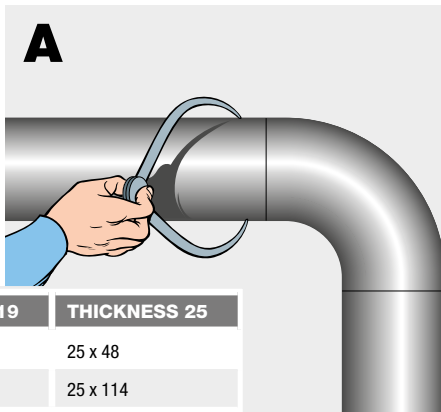

“T” FITTINGS

Take the measurements for the shape of the T-fitting.

Mark the measurements on the sheet and trace the shape of the through-section. The radius of the semi-circle corresponds to that on the piping.

Cut along the outline and glue the matching edges.

Position the through-section shape on the piping and join the glued edges.

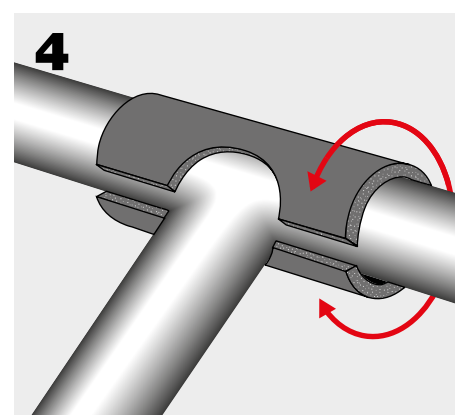
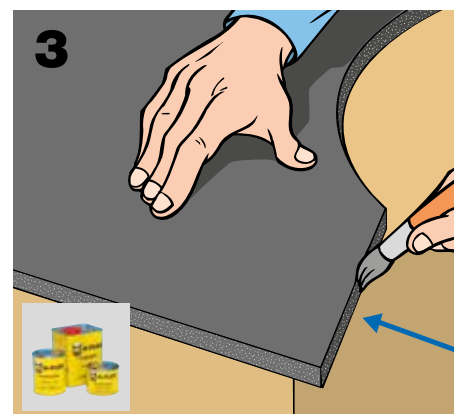
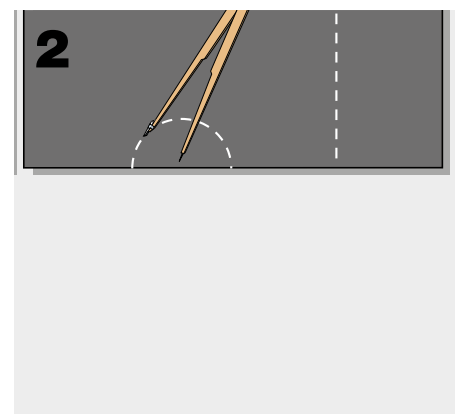
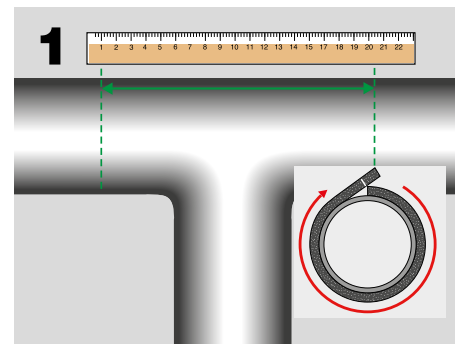

On another section of sheeting, trace the shape of the coupling arm, leaving enough overlap for the next section (a).

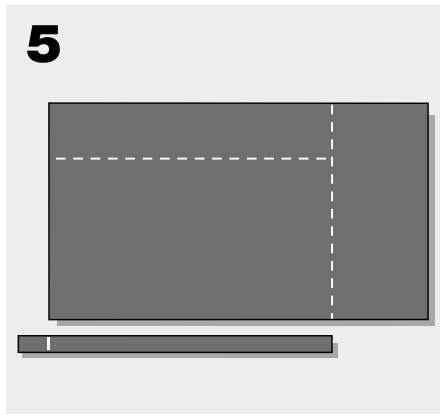

Take the measurements of the coupling arm section by resting the cut sheeting on it as a basis for measuring.

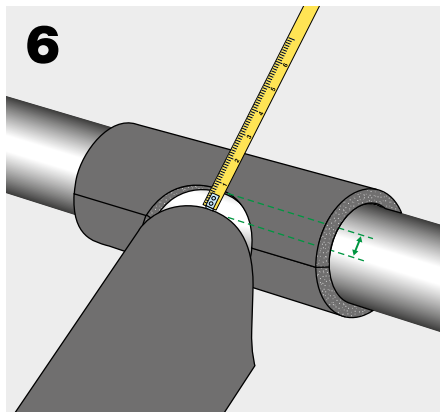

Mark the measurements of the section on the overlap of the previous tracing and draw the circles which define the section's elbows.

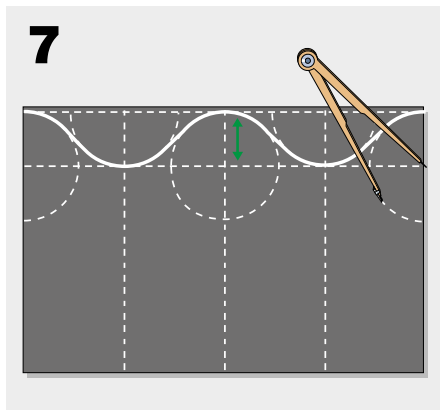

Cut along the final outline and glue the matching edges. Chamfer the edges of the upper, convex curves, towards the K-FLEX®'s inner surface.

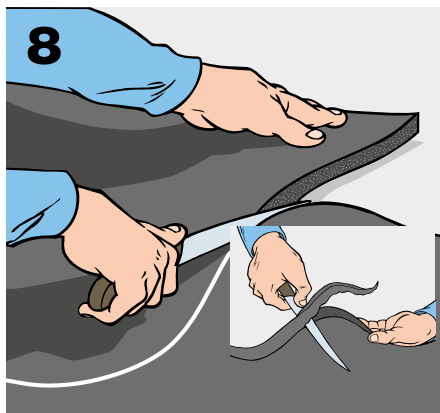

Position the prepared section on the coupling arm joining the parts of the T-fitting. Glue the chamfered curves to the throughsection.

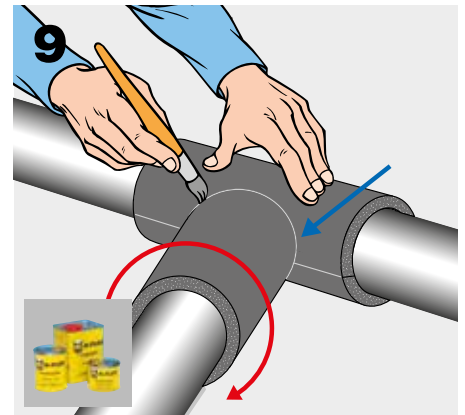

INSULATING T-FITTINGS WITH K 90

K-FLEX® produces prefabricated T-fittings in K-FLEX®, "T" K 90, in various thicknesses and diameters to simplify their application with considerable saving of time and material. Thanks to the precise production methods, the "T" K 90 give the installer excellent results.

Some examples of product correspondence:

Ø	THICKNESS 19	THICKNESS 25
48	13 x 48	19 x 48
89	13 x 89	19 x 89



Position the correct size "T" on the cross piping, after applying K-FLEX® glue to the inner edges to be bonded.

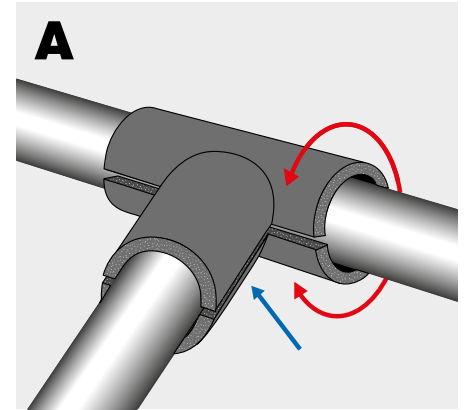

Join the glued edges by applying pressure.

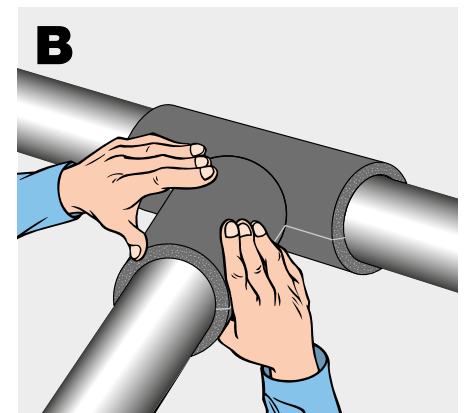

REDUCERS

To insulate a reducers section that connects pipes of different diameters, take measurements and mark them out on a K-FLEX® sheet. Measure the height of the collar section, including the welded joints.

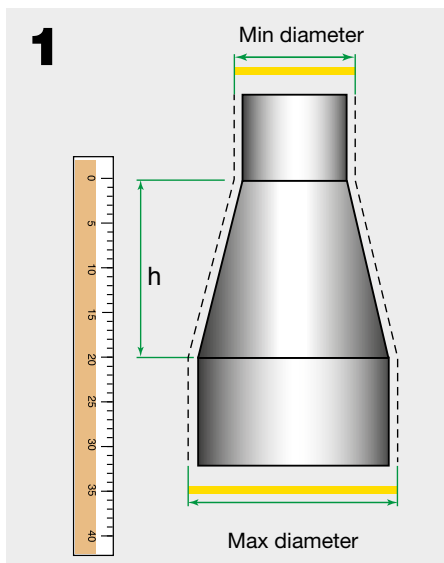

Use the calliper to measure the maximum and minimum pipe crosssections and add twice the thickness of the K-FLEX® to each measurement (see figure 1).

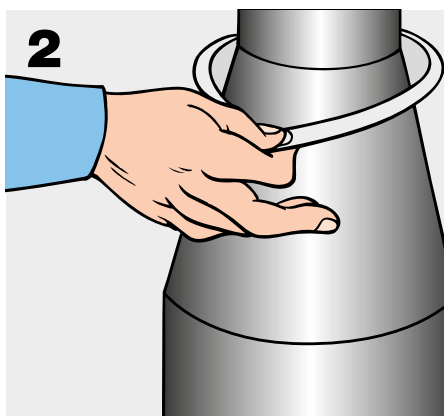

Carry over all the measurements (maximum diameter, minimum diameter, height) onto the sheet. Draw two lines from the ends of the measurements until they converge on a center point.

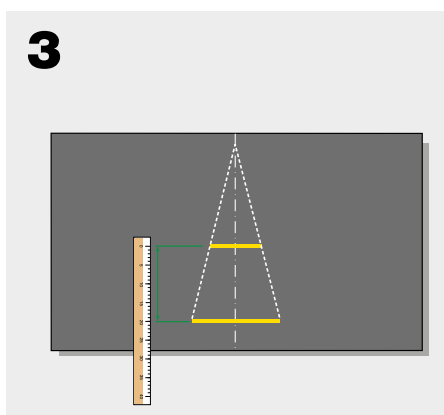

Using the compass, measure the distance between the point of intersection and the two diameters and draw two arcs.

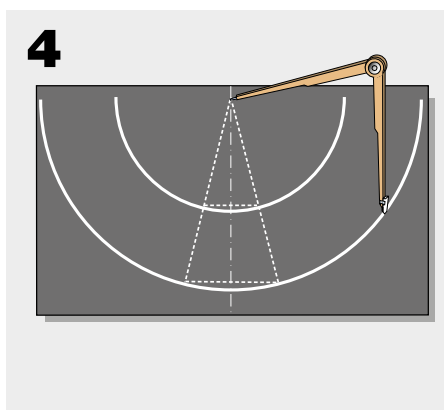

Measure the circumference of the widest pipe using a strip of K-FLEX® of the same thickness as the sheet.

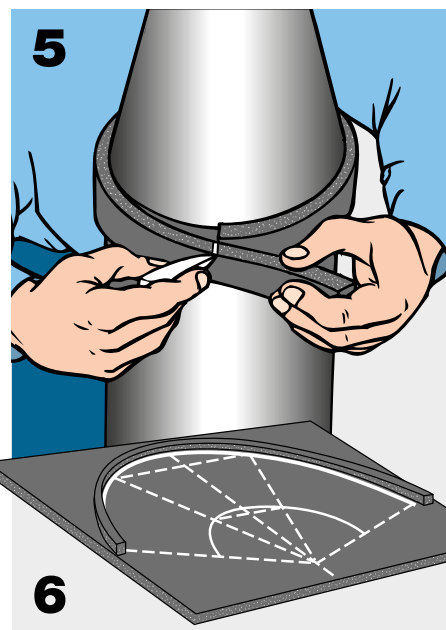

Mark the center of the circumference on the strip, and line it up on the larger of the two arcs. Draw two lines from the ends of the strip to the center of convergence.

Carefully cut out.

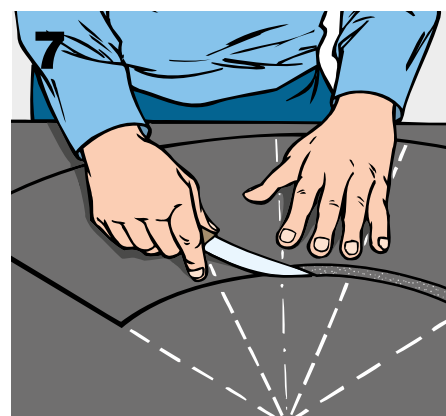

Glue the edges and, after they have dried, fit the insulation to the collar. Press the two edges together starting at the far ends.

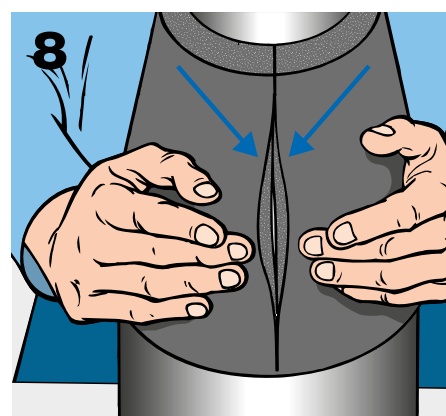

Glue the upper and lower edges and attach the other K-FLEX® sections.

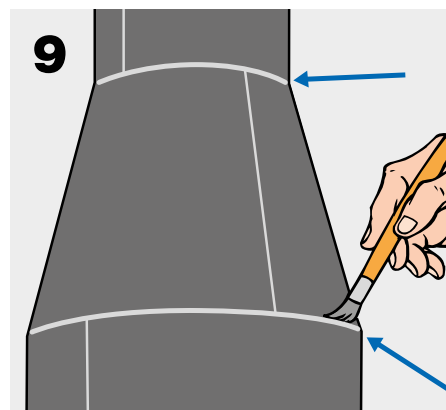

FLANGES

Insulating a flange is reasonably simple, but requires the K-FLEX® sheeting to be accurately cut into two rings.

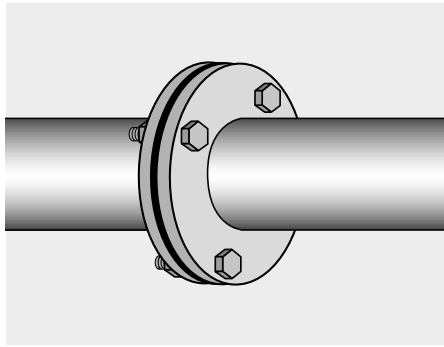

Firstly, insulate the pipes as far as the flange on either side.

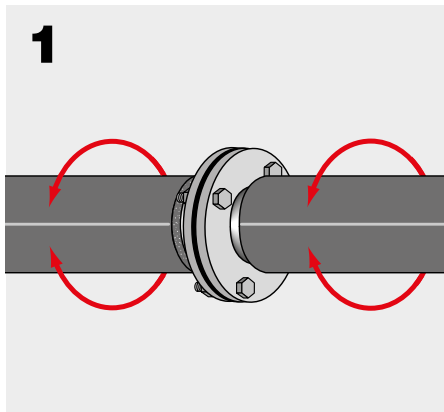

Measure the pipes' circumference with the K-FLEX® around it...

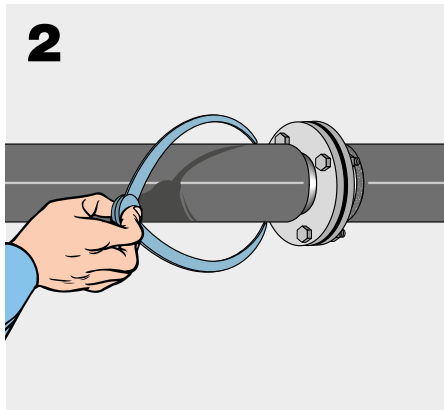

.... along with that of the flange. Use the measurements of the two diameters to calculate the respective inner and outer radii.

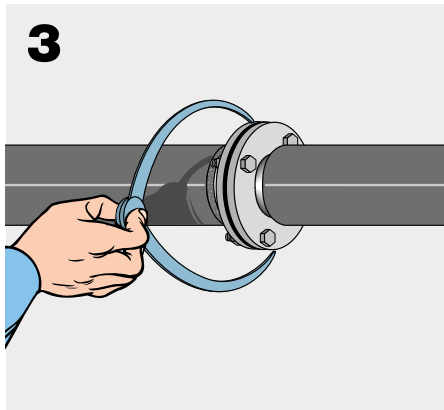

After calculating the two radii, draw the inner and outer circumferences of the rings on two separate squares of K-FLEX®.

Attaching a sharp blade to the tip of the compass allows the first incision to be made so that a knife can then be used to cut out the ring. However, a knife alone can give acceptable results.

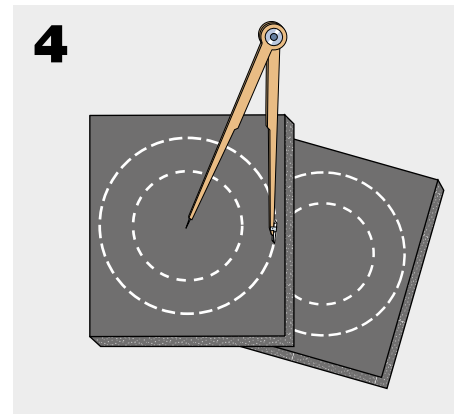

Cut the rings out and make an opening on one side to attach them around the pipes.

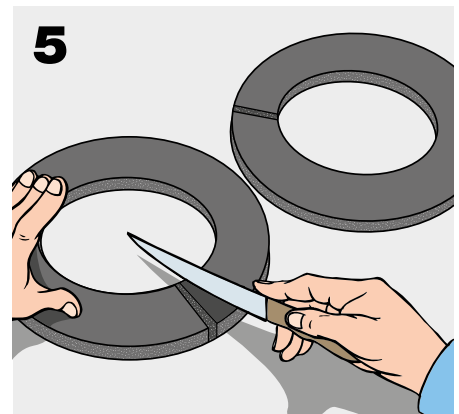

Position the rings around the ends of the insulating tube and glue the opening with K-FLEX® glue.

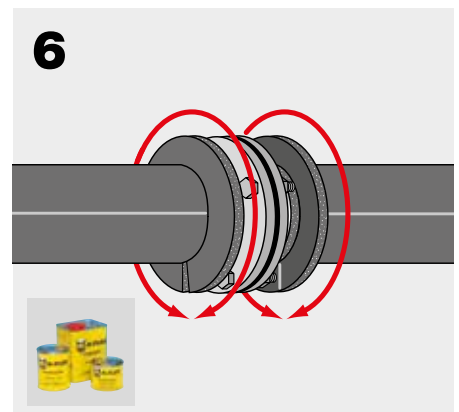

Use a strip of K-FLEX® of the same thickness to measure the circumference of the insulating rings.

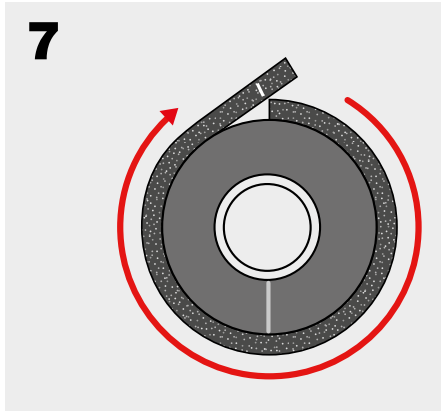

Mount it around the rings and glue the edges.

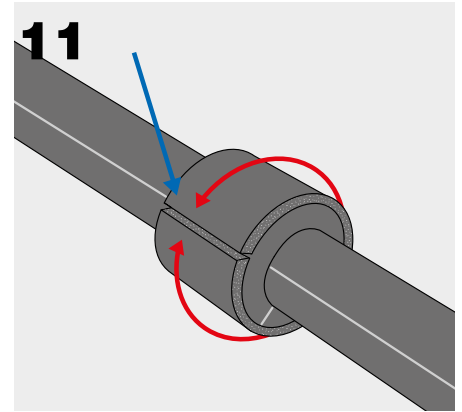

Measure the distance between the two rings, including the thickness of the insulating material itself.

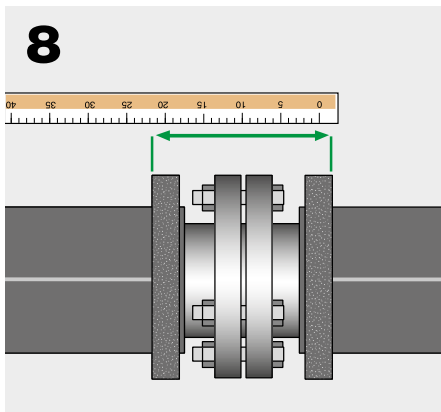

Stick the sleeve section to the outer edges of the rings, then stick the inner surface of the rings to the ends of the adjacent tubing.

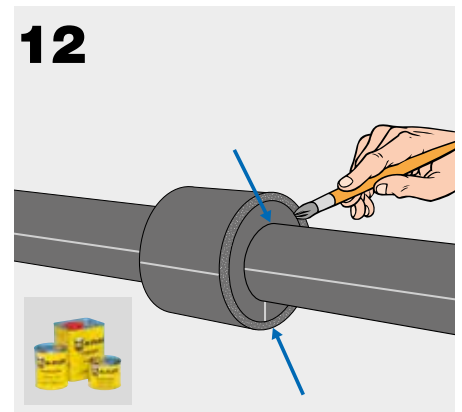

Draw the measurements out onto a K-FLEX® sheet to get the outline of the sleeve that will complete the flange's insulation. If required, to reduce material scrap, use a K-FLEX® strip of proper dimension.

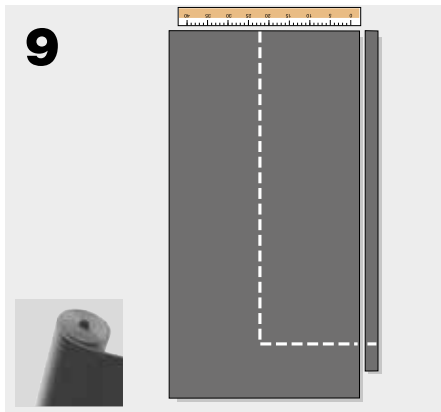

Cut the sleeve section out.

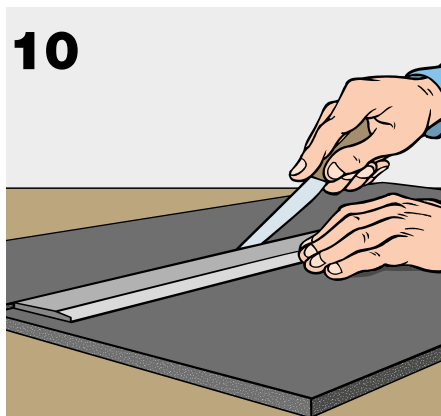

VALVES

Before starting to insulate the valves housing, first fit tubing to the pipes either side of it.

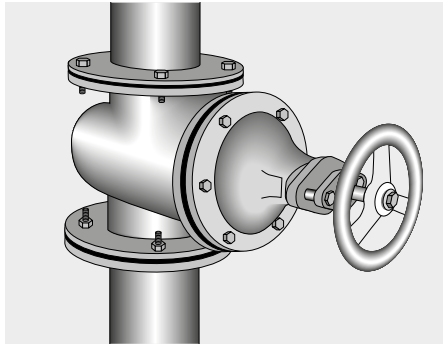

Measure the diameter of the insulated pipes and the flanges. Use these measurements to calculate the relevant radii.

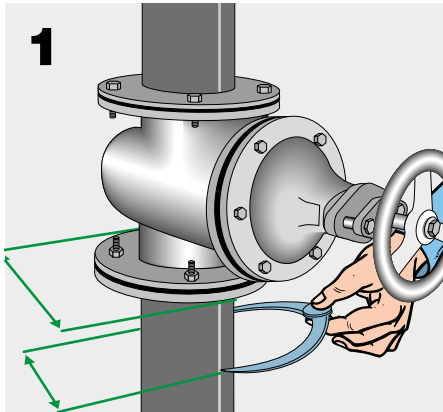

After calculating the radii, mark out the respective inner and outer circumferences on two separate squares of K-FLEX® of the same thickness.

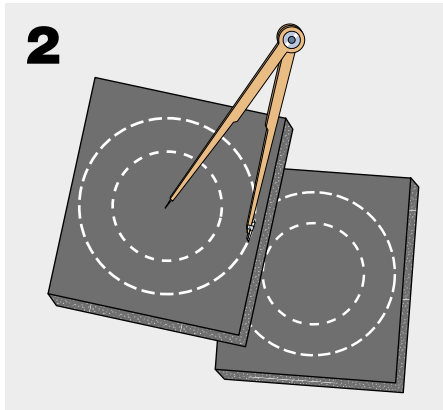

Carefully cut out the rings.

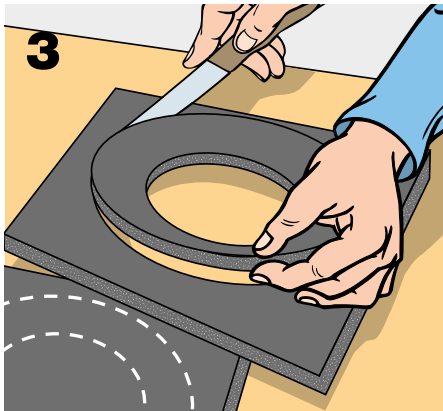

Make an opening so that they can be fitted over the pipes.

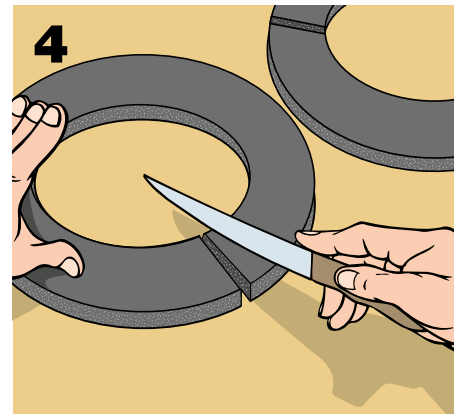

Put a ring on the outside of each flange and glue their edges together with K-FLEX® glue.

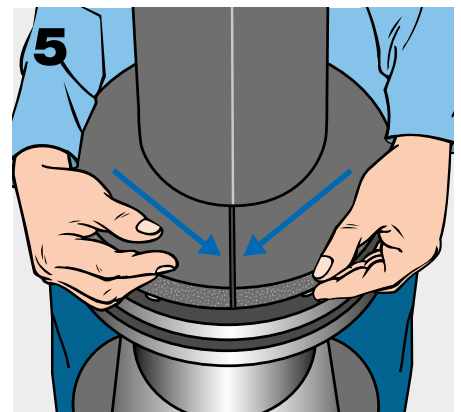

Stick the inner surfaces of the rings to the ends of the insulating tubing covering the pipes.

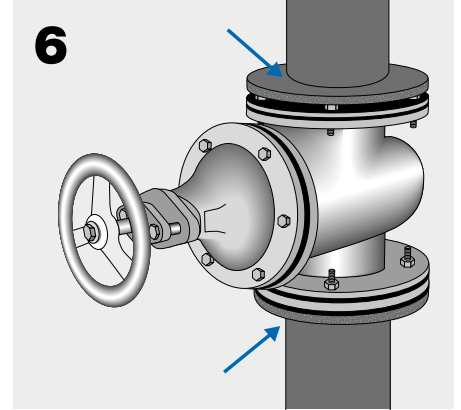

Using a strip of insulation of the same thickness, measure the circumference of the rings.

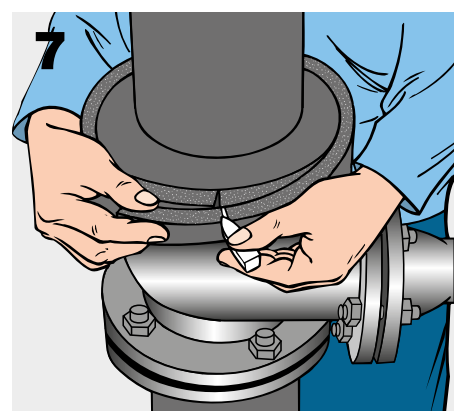

Measure the distance between the rings, including the thickness of the rings themselves.

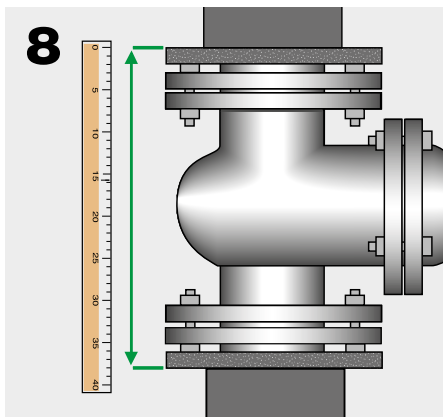

If there are any imperfections along the cut edges, smooth them slightly so that they bond precisely.

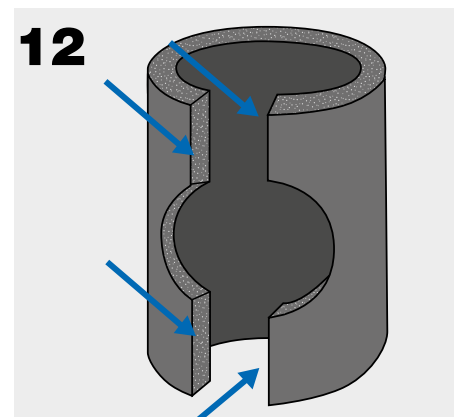

Draw the outline of the sleeve section measurements onto a sheet of K-FLEX® and draw a line down the middle.

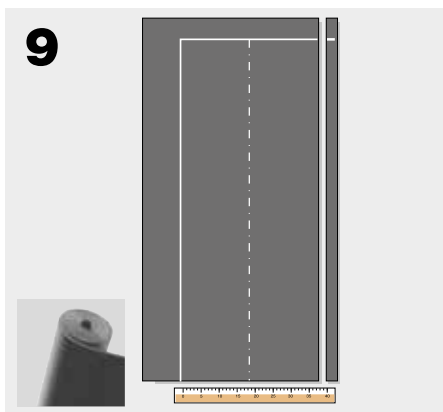

Once the glue is dry, fit the sheeting around the rings and stick the edges together.

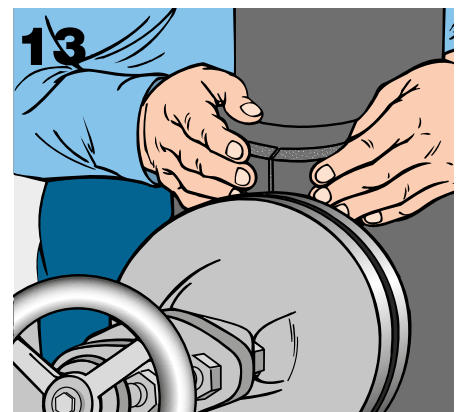

Measure the diameter of the stopcock housing.

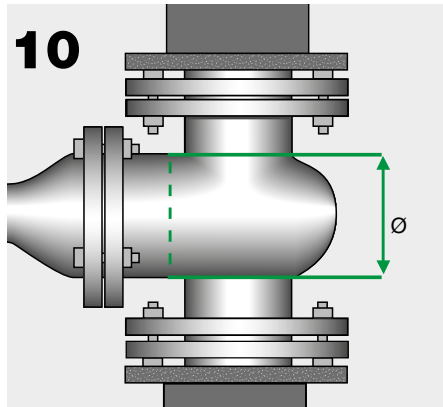

Next, calculate the shape of the disc for the front flange. Measure the circumference of the supporting flange and the form of the face plate around which the disc must fit.

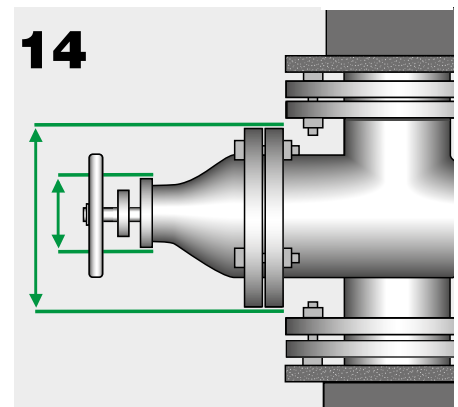

Divide the diameter by two to get the radius. Place the compass at the end of the sleeve's center line and draw a semicircle at each end.

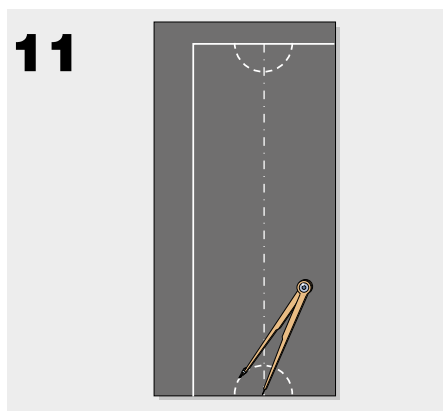

Mark out the measurements on a piece of K-FLEX® and cut the disc out.

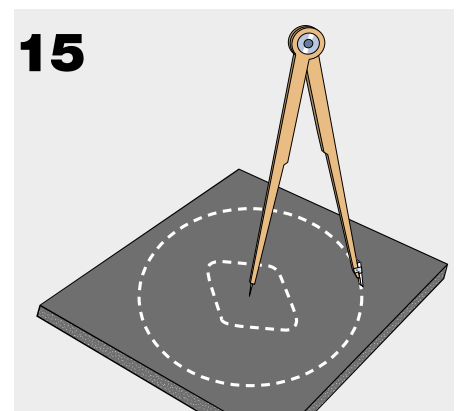

Make an opening so that the disc can be fitted over the face plate.

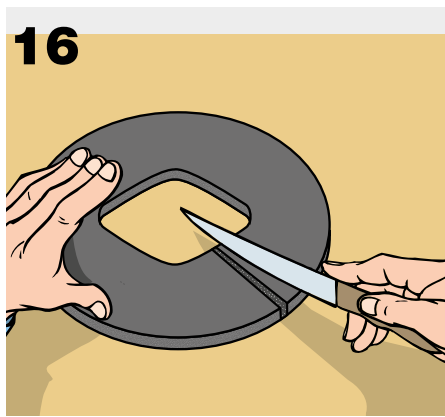

Position the disc and stick the edges together with K-FLEX® glue. Make sure to stick the inside edges to the face plate, too.

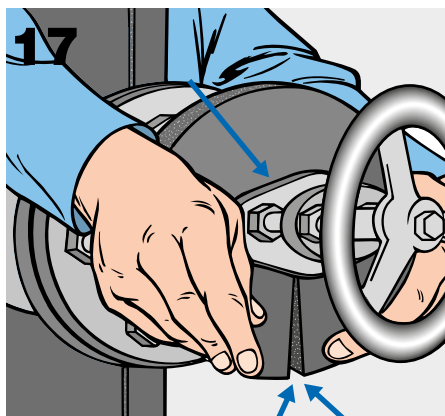

Once it is in position, measure the circumference of the disc.

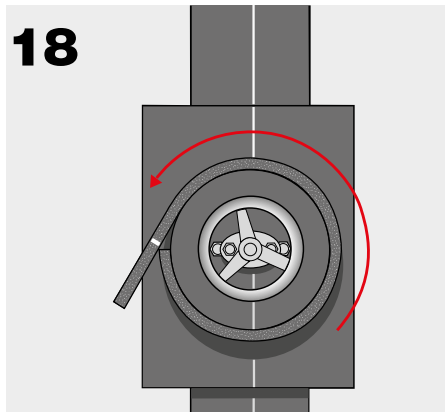

Mark the measurement out on a piece of K-FLEX® of the same thickness and divide its length into four equal parts.

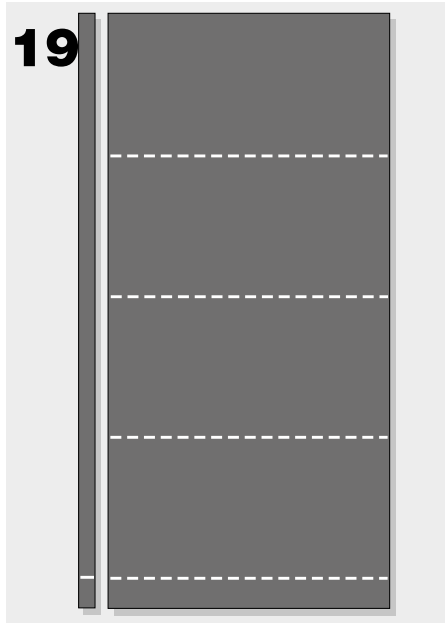

Measure the distance between the disc and the existing lagging at its nearest and furthest points.

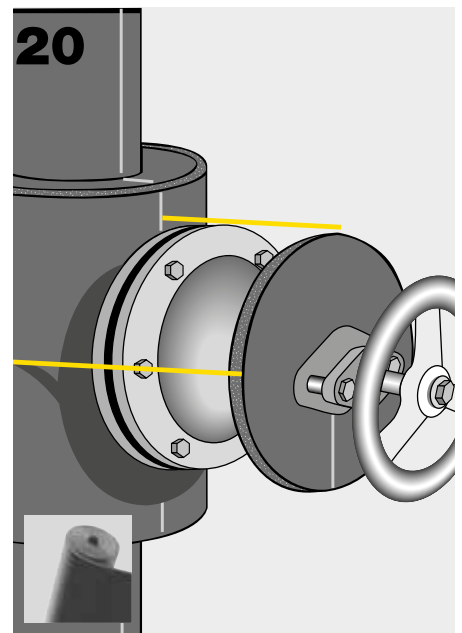

Mark the two different measurements on the dividing lines of the tracing, as illustrated, then draw the intersecting lines from one extremity of the shape to the other.

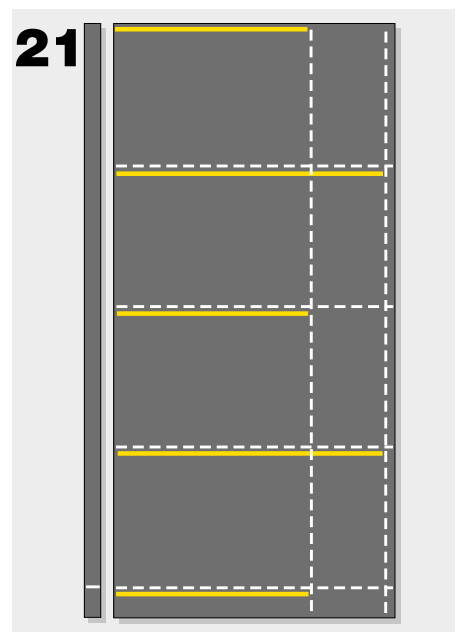

Using the difference in the two lengths as a radius, draw circles around the ends of the lines. Using the arcs of the circles, draw a continuous line linking them up, as illustrated.

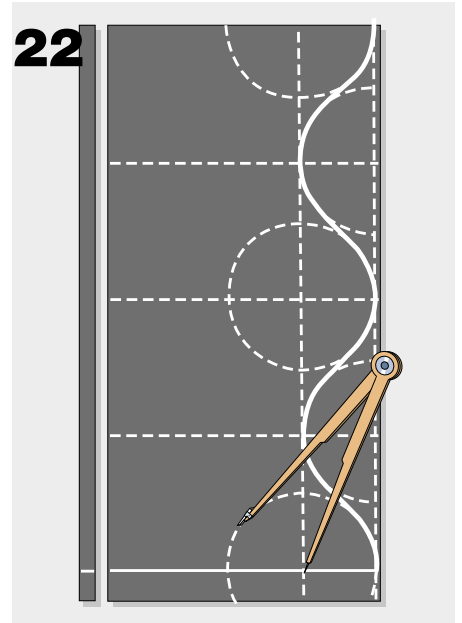

Carefully cut along the line.

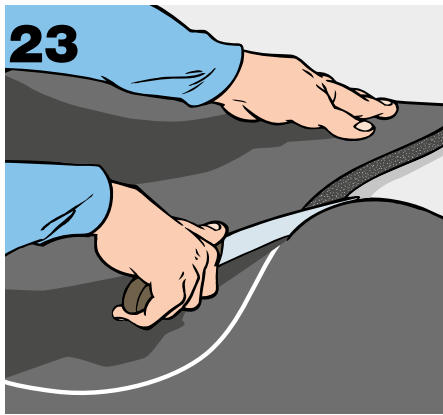

Check the various parts which haven't been stuck together yet. Use a brush to insert glue between the surfaces to be stuck together and press them together.

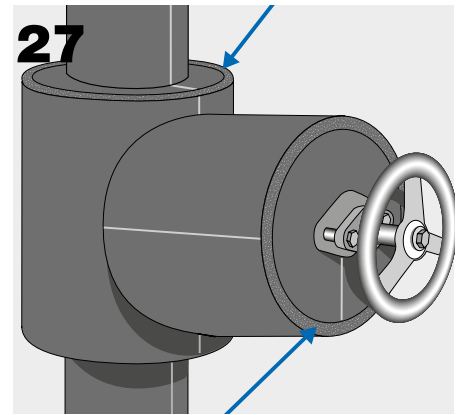

Chamfer the edges of the upper, convex curves towards the K-FLEX®'s inner surface.

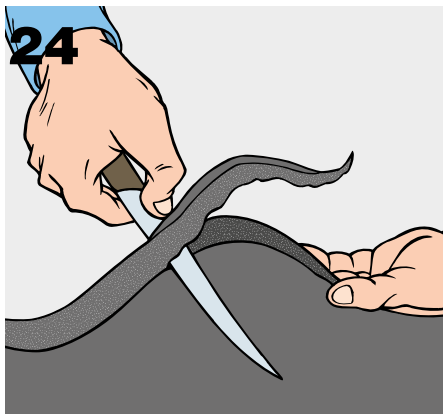

The stopcock is now completely sealed.

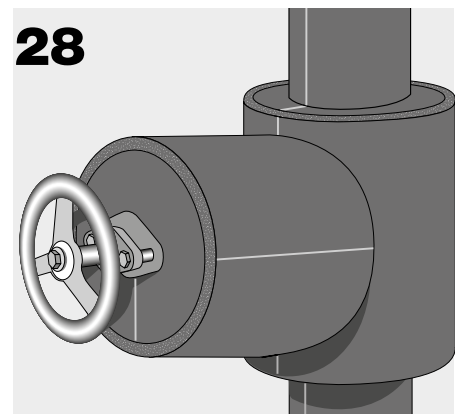

Glue the leading, straight edges, let them dry, then fit the resulting sleeve around the disc.

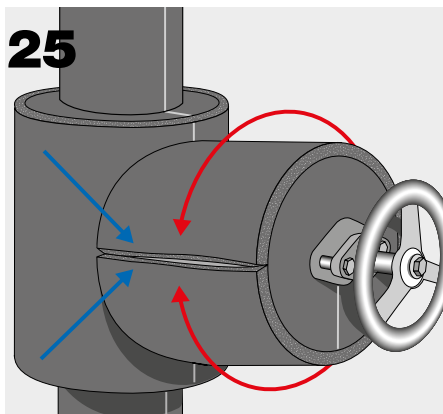

Stick the sleeve onto the insulation around the main stopcock housing using K-FLEX® glue.

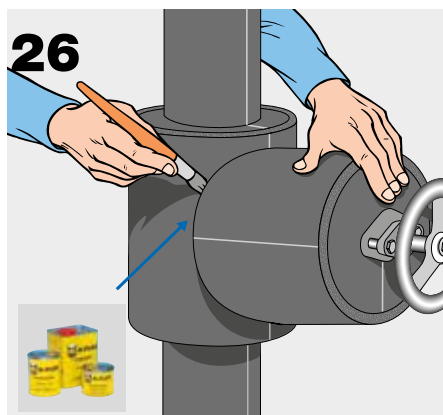

ANGLED VALVES

Before insulating an angled valves, first lag the pipes either side of the flanges.

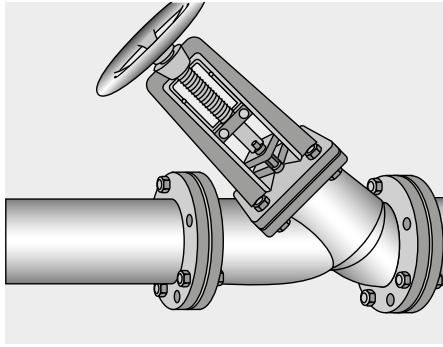

Following the same procedure as on page 49 (insulating flanges), make two rings of K-FLEX® and fit them over the tubing next to the flanges.

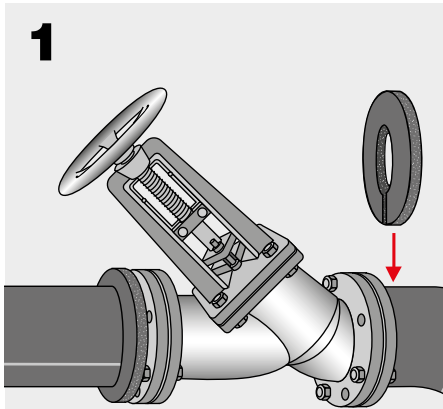

Measure the distance between the two K-FLEX® rings, including the material itself, and the distance between each ring and the stopcock housing.

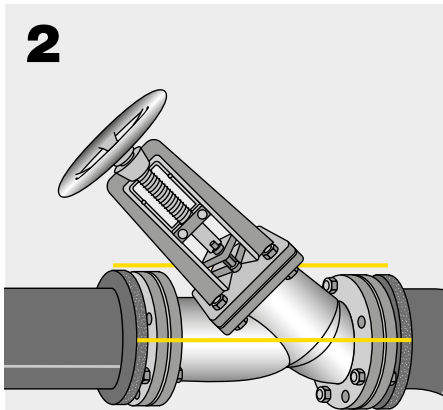

Measure the diameter of the base of the stopcock housing. Use this to calculate the radius needed to draw the circumference in point 5.

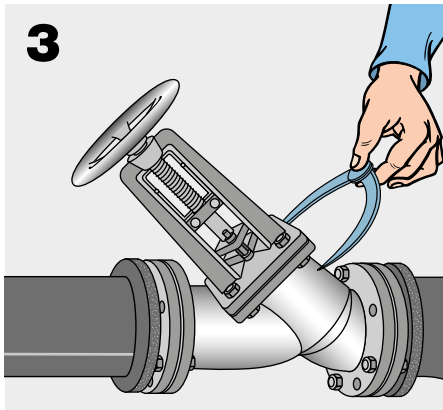

Measure the circumference of the rings.

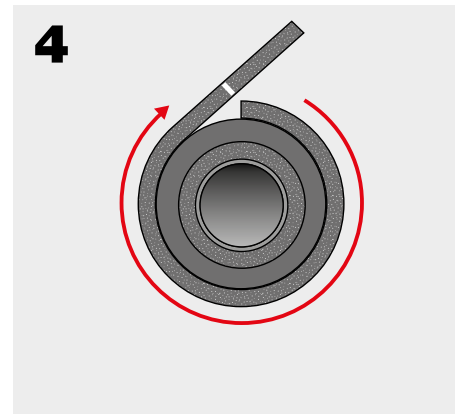

Mark the measurements of the rings' circumference out on a sheet of K-FLEX® (figure 4), along with the semicircles for the base of the housing (figure 3) positioned along the length of the sleeve according to the measurements taken in figure 2.

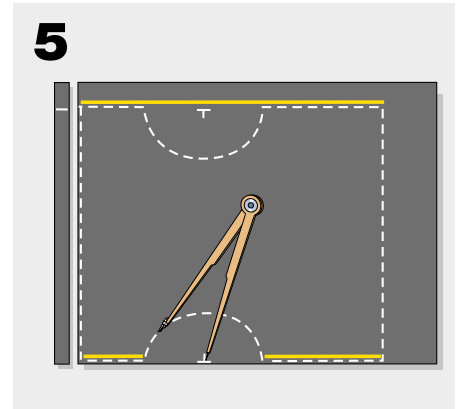

After cutting the piece out, wrap it around the rings to seal the central stopcock housing, then stick the edges together using K-FLEX® glue.

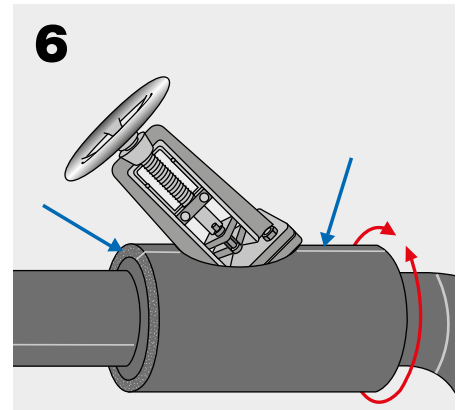

Cut out a second sleeve section to fit around the stopcock mechanism.

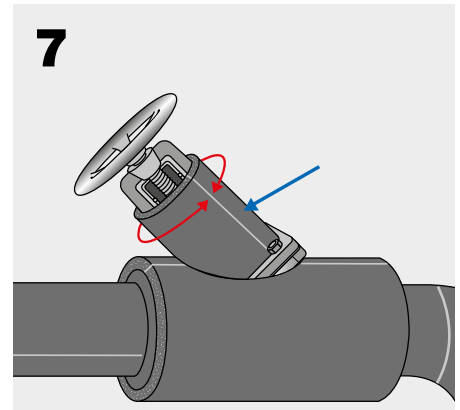

Cut out a ring of K-FLEX® the size of the stopcock wheel. The inner diameter should be the same as the outer circumference of the sleeve already attached.

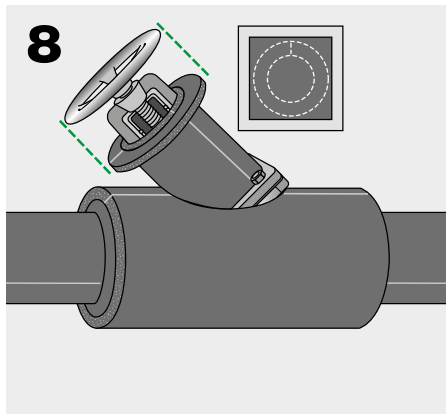

Measure the distance between the ring and main housing insulation at the two points, a and b.

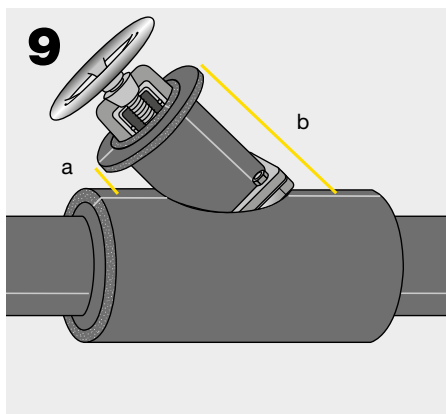

Draw the shape of the sleeve on a K-FLEX® sheet, using a compass and the measurements taken. The reference circle in the middle has a radius equivalent to a quarter of the diameter of the stopcock housing already insulated (see figure 6).

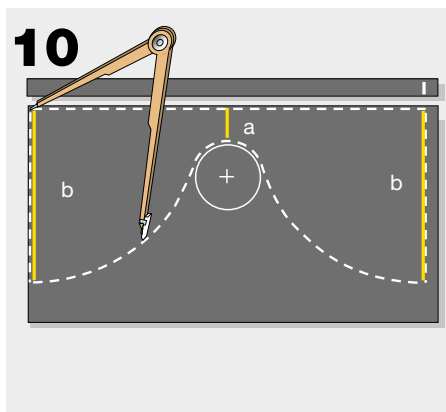

Join the two semicircles and cut along the line.

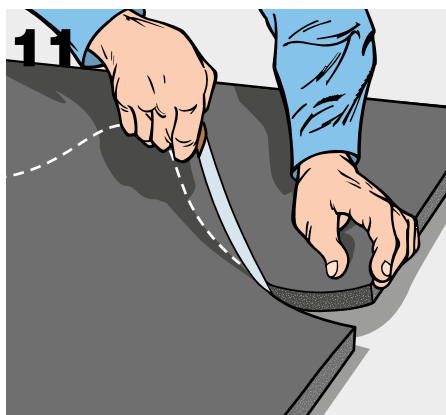

Chamfer the curved edge towards the inner surface.

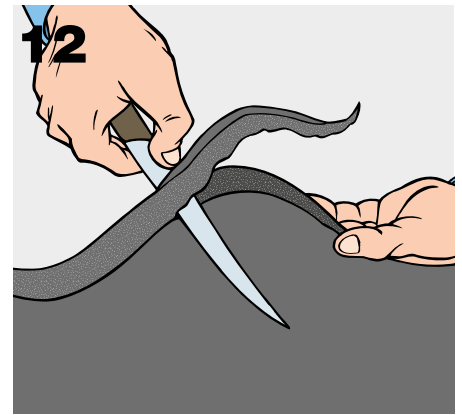

Attach the insulation material around the ring and glue all the surfaces it comes into contact with.

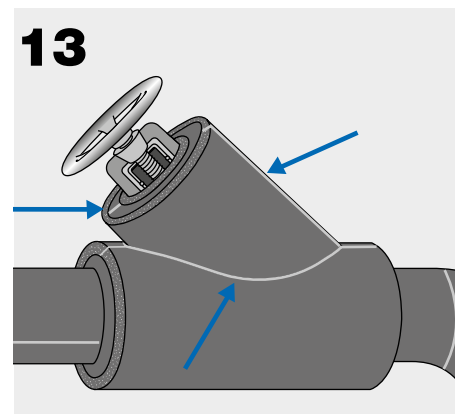

Make a cylindrical, removable cap with a strip of K-FLEX®. The dimensions to use are shown in the figure.

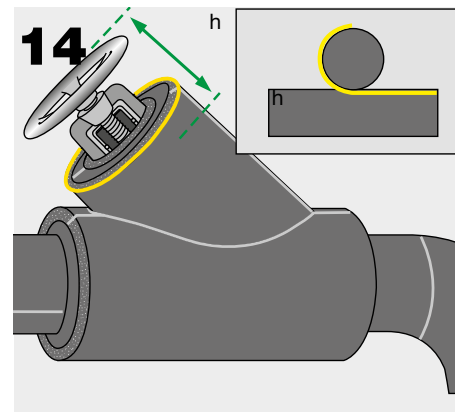

The cap should slide on and off easily. Once this is ensured, stick the edges together with K-FLEX® glue.

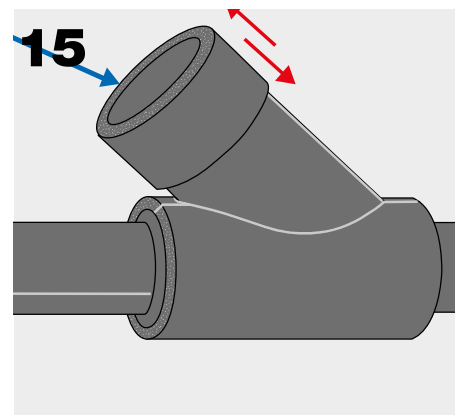

TANKS

Before insulating, clean the whole surface carefully with K-FLEX® thinner.

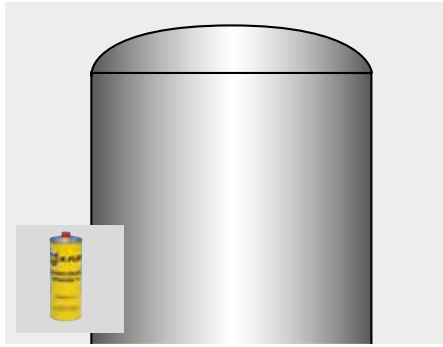

First of all, insulate the tank walls. Use the same method as with piping. Measure the circumference of the tank with a strip of K-FLEX®, and measure the height.

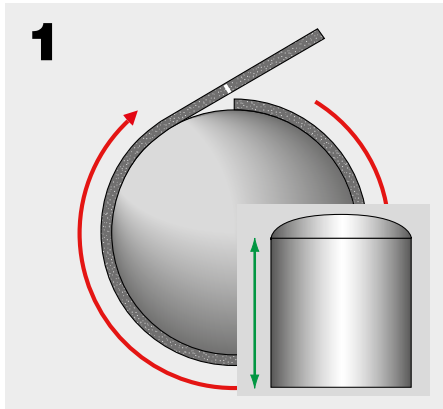

Mark the dimensions out on a K-FLEX® sheet and cut out. Spread K-FLEX® glue over the entire surface of the sheeting with a flexible spatula and, with a brush, over the walls of the tank. Glue the edges of the sheet, then stick the insulation to the tank, joining the edges together.

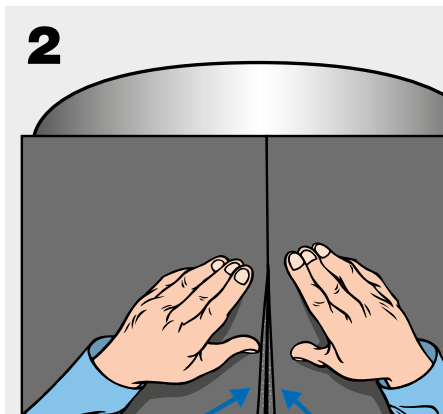

To insulate the domed surface, first measure its overall diameter with a strip of the same K-FLEX®.

As the area to cover is substantial, ensure you have enough insulating material and glue sheets together if necessary.

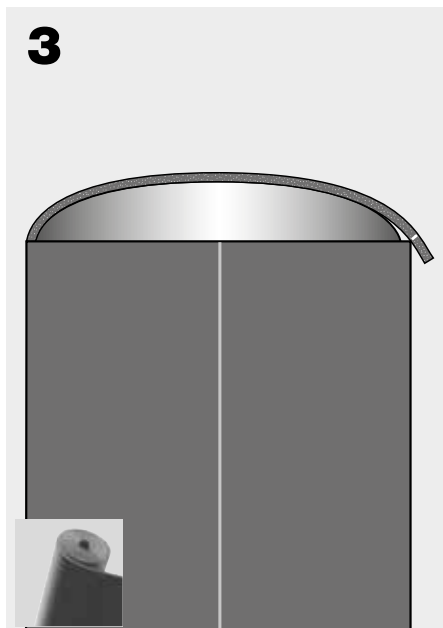

Use the diameter to calculate the radius and draw the complete circumference.

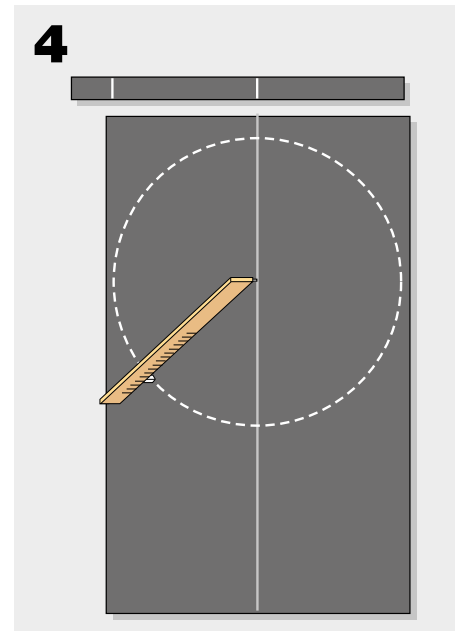

Cut the circle out accurately.

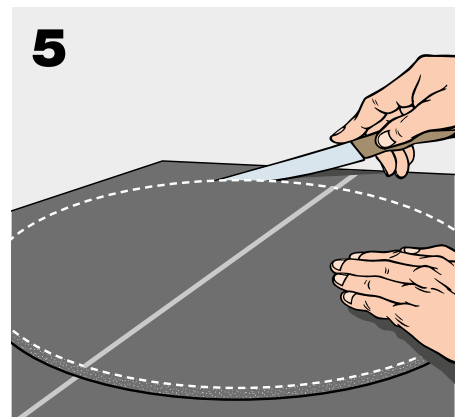

Coat the disc...



...and the top of the tank with K-FLEX® glue.

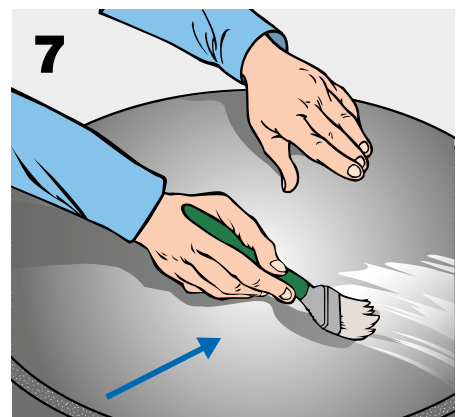

Place the K-FLEX® disc on the top of the tank and press it down firmly from the center outwards to avoid it moving.

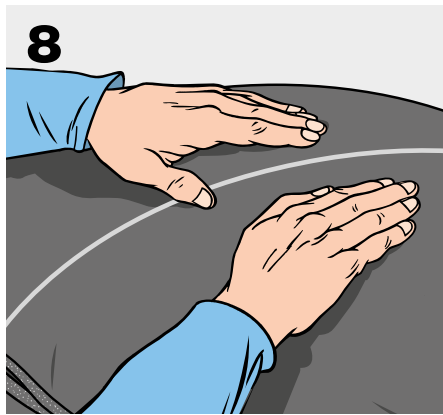

When the sheet has stuck, glue the edges all the way round.

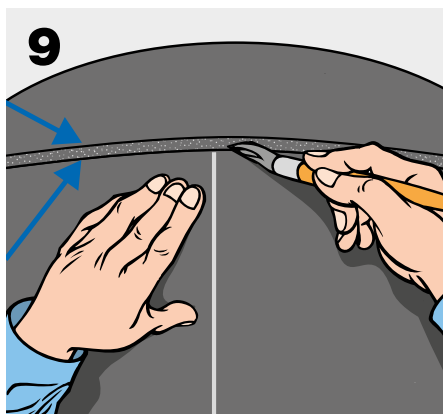

Leave to dry, then press firmly together.

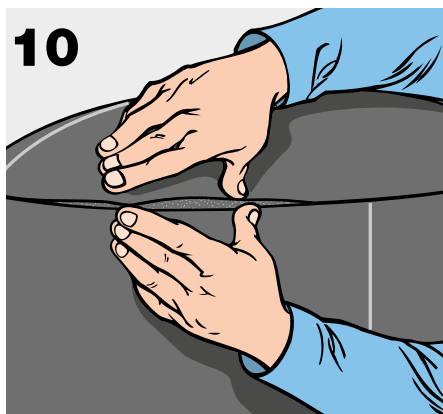

When insulation sheets are applied on flat surfaces or on cylindrical objects with a diameter of ≥ 600 mm, the sheets must be fully bonded to the substrate. Joints and seams must also be completely bonded. (Source: DIN 4140)

For multilayer insulation on vessels, tanks, columns, or other large objects, supporting and load-bearing constructions are required. The high loads can also be absorbed by using fastening or tension bands, or by installing specially designed cold supports.

INSULATING DUCTINGS WITH STANDARD SHEET

Use K-FLEX® thinner to thoroughly clean the surface to be insulated. Insulation is not recommended where there is incrustation or other flaws which could prevent the sheeting from sticking perfectly.

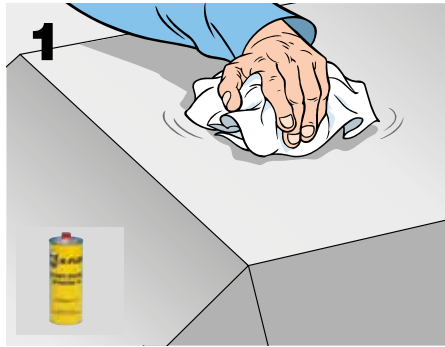

Mark the measurements of the surface to be insulated on the sheeting and cut the required size out of the roll.



Apply K-FLEX® glue to the surface which has to adhere to the conduit, and to the conduit surface. Use K-FLEX® glue to join the edges together. In the example given, for the best results we recommend first to insulate the lower surface of the conduit, then the side walls and lastly the top. This will prevent the penetration of humidity.

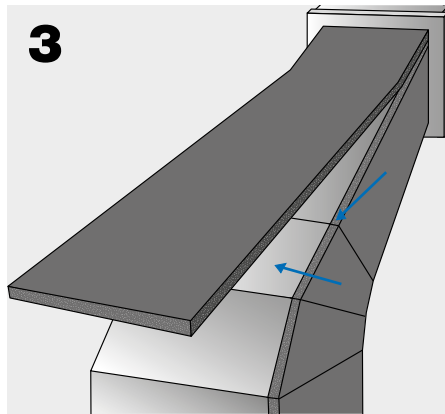

Use K-FLEX® glue to join the edges together.

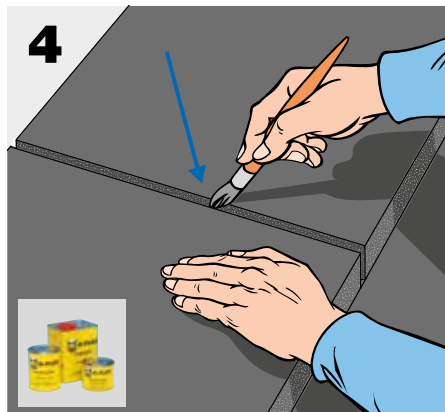

INSULATING DUCTINGS WITH SELF-ADHESIVE SHEET

Using self-adhesive sheeting, carry out the same cleaning and cutting procedures as indicated for standard sheeting. The backing paper must be removed from the adhesive side before sticking it to the conduit surface.

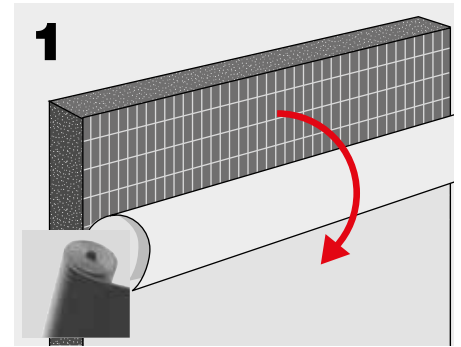

Position the uncovered edge at the starting point (a). Pull the backing paper off gradually, pressing the material down as you go. Use K-FLEX® glue to join the edges together. In the example given, for the best results we recommend first to insulate the lower surface of the conduit, then the side walls and lastly the top. This will prevent the penetration of humidity.

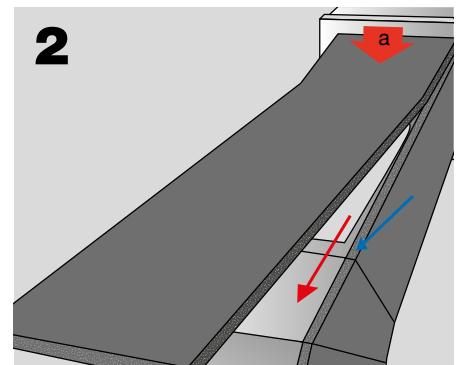

Use K-FLEX® glue to join the edges together.

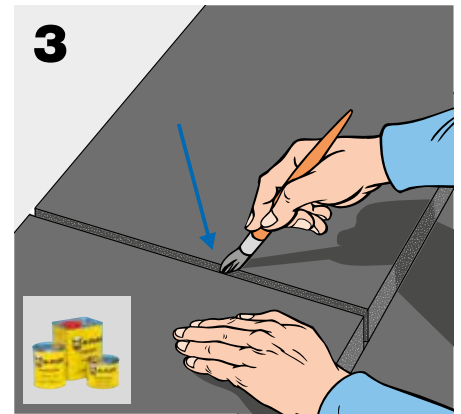

Please note: For K-FLEX® S2 products, flange sections must be cut as four-sided corner pieces rather than wrapped entirely around as conventional strip sections.

For **outdoor applications** (only with specially clad material) it is necessary to avoid water stagnation along the horizontal sections for which the material must therefore be installed so as to guarantee a slope of not less than **3° - 5°**

K-FLEX® PVC ACCESSORIES



K-FLEX® PACK RS 590

Protective sheet. This is a self-winding, rigid PVC sheet with a smooth, grey coloured surface, in rolls.

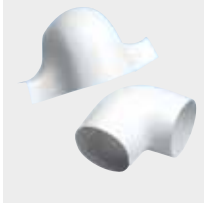

K-FLEX® PACK BENDS CA 200 W type

90° PVC single-piece bends in laminated plastic, suitable for threaded-welded fittings. Easy to install, they are fixed with plastic tacks.



ADHESIVE TAPE IN PVC grey/black AT 070

Adhesive insulating tape. Special PVC insulating tape for covering gaps or finishing off insulated sections. The tapes come in various sizes.

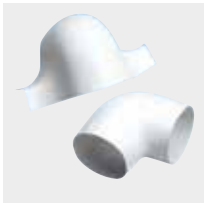

K-FLEX® PACK CURVES SE 90 S type

90° PVC curve, one single piece moulded in laminated plastic. Easy to install, it is fixed by means of plastic rivets.



FIXING MATERIALS

Plastic awl and rivets for correct fixing of K-FLEX® PACK blade and relevant curves.



ALUMINIUM TERMINALS IN ROLLS

Special terminal tapes in ribbed aluminium for sealing the ends of piping insulated with PVC. Available in: pale grey, blue or red.

K-FLEX® PVC: SHEETS AND BENDS

PROTECTING INSULATING TUBING WITH K-FLEX® PACK RS 590 SHEET

Cut a section of the sheet to the same size as the circumference of the insulating tubing (a), with a few centimeters extra for the overlap.

Wrap the sheet over the insulating material, overlapping the edges.

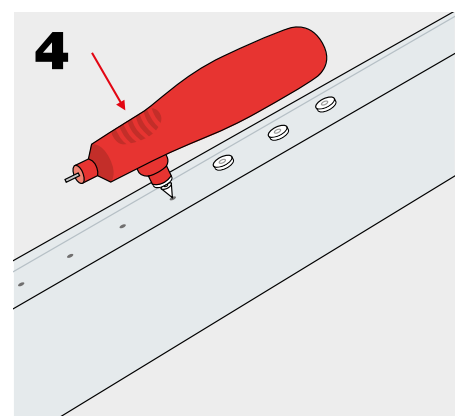
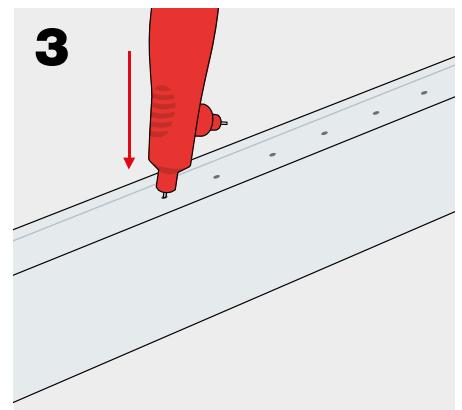
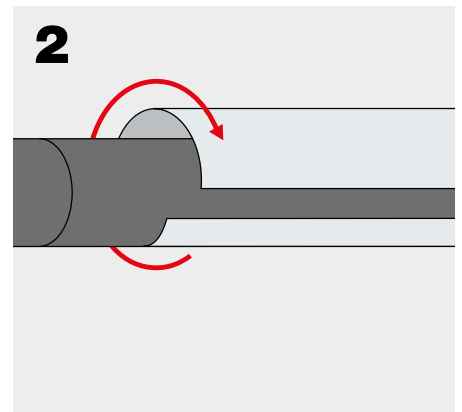
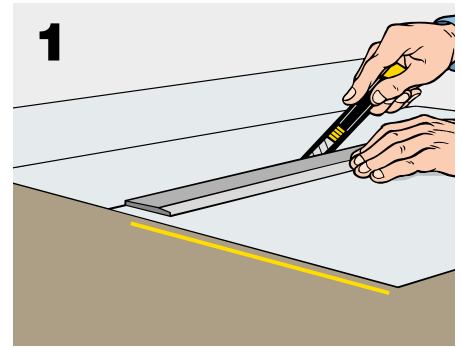

With the end of an awl, make holes along the overlap, going through both layers of the sheet.

Drive the tacks into the holes and as far as the layer of insulating material.

PROTECTING 90° BENDS WITH K-FLEX® PACK SE 90 type S and CA 200 type W

After taking the measurements and choosing the most suitable type of K-FLEX® PACK bend, position it on the part to be lagged. The inner edges will overlap to allow for fixing.

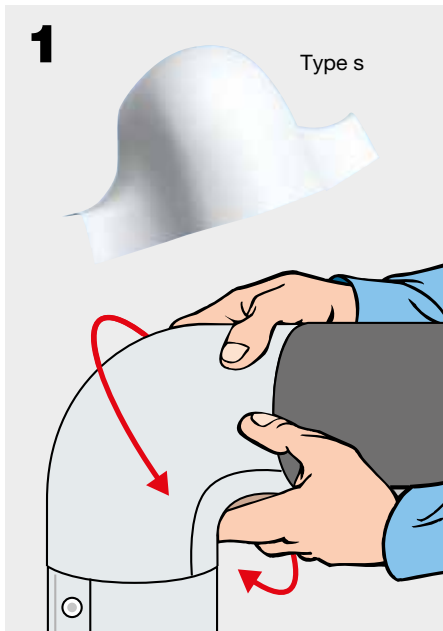

Make holes through the two parts on the bend, using the awl head.

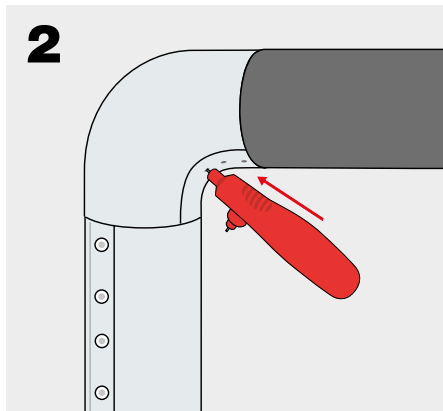

Drive the plastic tacks into the holes, using the awl. Continue covering the insulating tubing with K-FLEX® pack sheet (a).

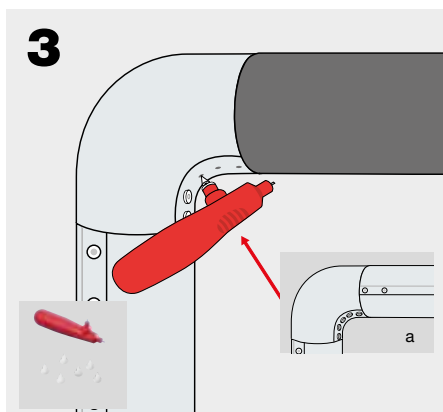

FINISHING WITH AT 070 PVC ADHESIVE TAPE

The joints in the K-FLEX® PACK sheets and bends must be sealed to insure continuous insulation.



Wind the tape tightly around the joints on the straight sections...

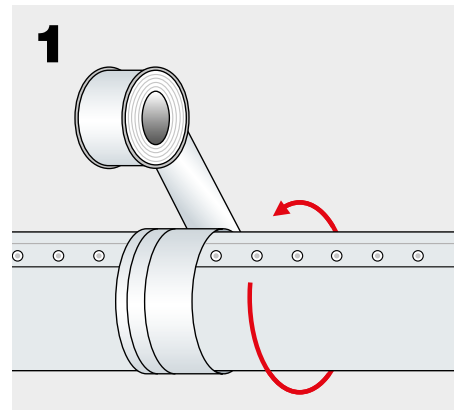

...and at the bends.

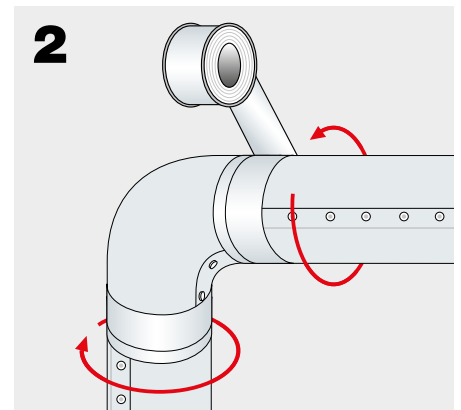

K-FLEX® ALU: FOILS AND ELBOWS

PROTECTING THE INSULATING TUBING WITH K-FLEX® EMBOSSED ALU R 200 SHEET

Cut a section of sheet to the size of the insulating tubing's circumference (a), plus a few extra centimetres for overlap.

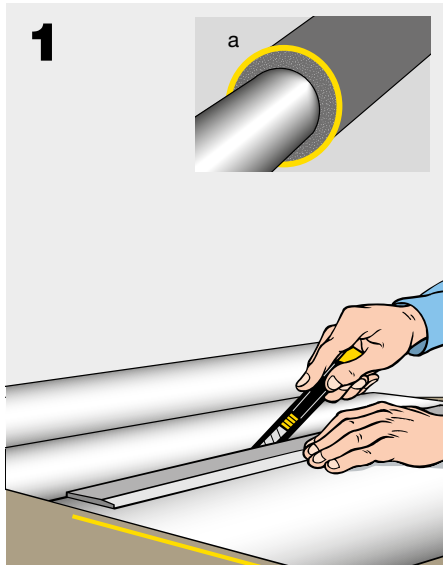

Wrap the sheet around the tubing, overlapping the edges.

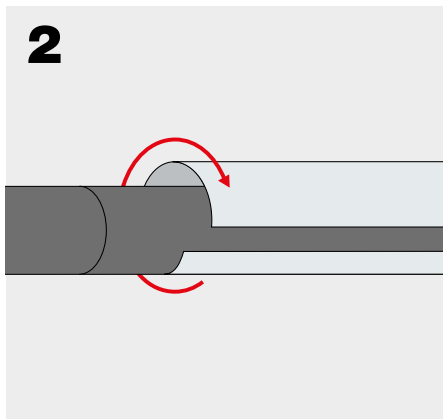

Fix the aluminium sheet with metal tacks. a) Fix the tack into the awl's magnetic slot. b) Drive the tack into the sheet, by pressing down the awl.

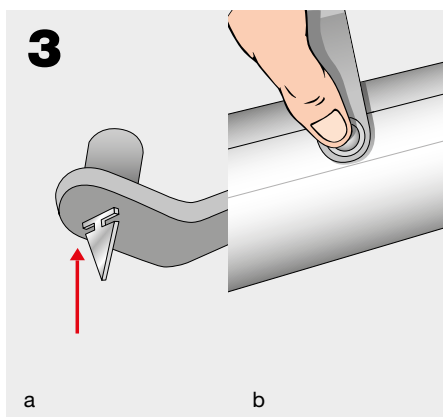

c) Rotate the awl 90°
d) Check that the tack is at right angles to the entrance slot.

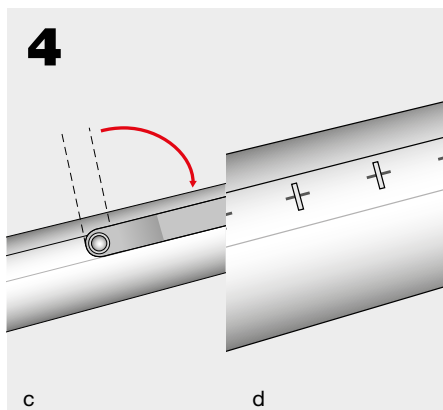

PROTECTING THE INSULATING TUBING WITH K-FLEX® EMBOSSED ALU CB 200 BENDS

After measuring, apply it to the part to be lagged. The inner edges will overlap to allow fixing.

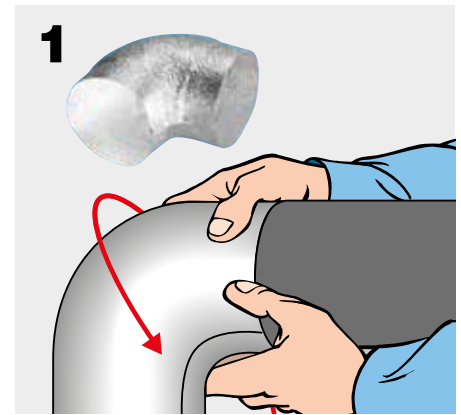

Make the necessary hole through both parts covering the bend.

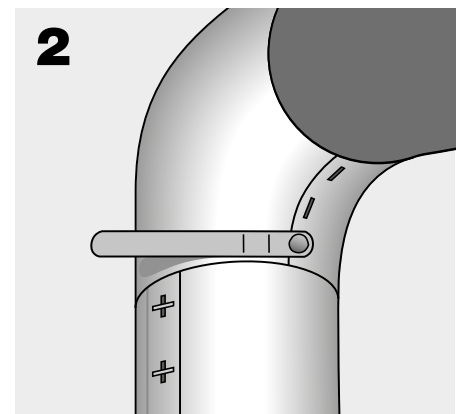

Drive the metal tacks into the holes and use the awl to turn them at right angles. Continue covering the insulating piping with K-FLEX® ALU sheet (a).

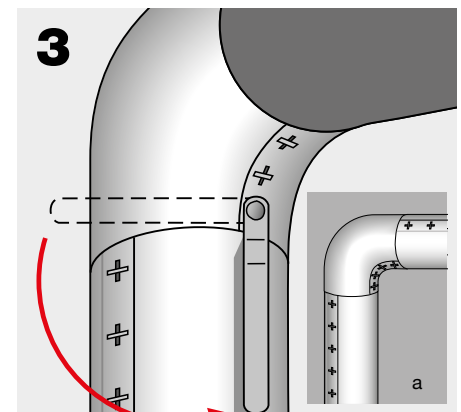

FINISHING WITH WOVEN REINFORCED ALUMINIUM TAPE AR 107 AND K-FLEX® ALU AA 130

The joints on K-FLEX® ALU sheet lagging and bends must be sealed to ensure perfect insulation.



Wind the tape tightly around the joints on the straight sections...

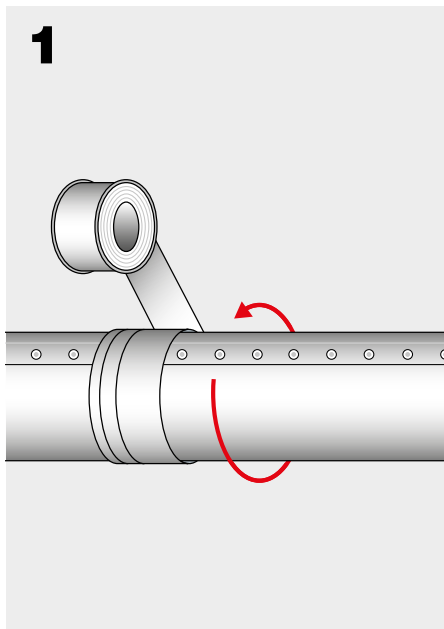

...and on the bends.

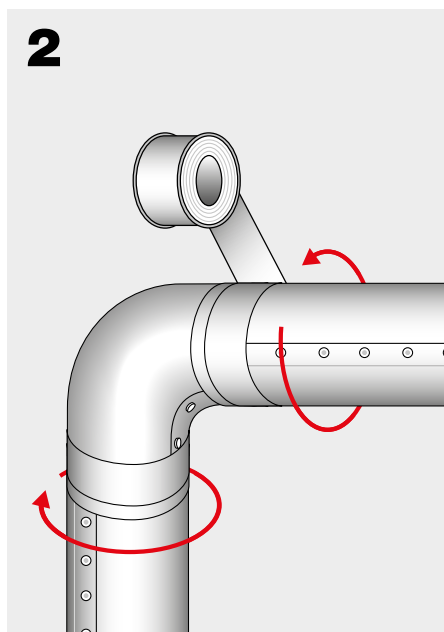

APPLYING ALUMINIUM TERMINALS

The adhesive aluminium terminal tape is available in 4 colours which can be used to identify the different piping in a system. This product can be used on every type of insulating material. Glue a plug of insulating material to the end of the terminal (a). Cut a strip of terminal tape which more than covers the circumference of the insulating pipe.

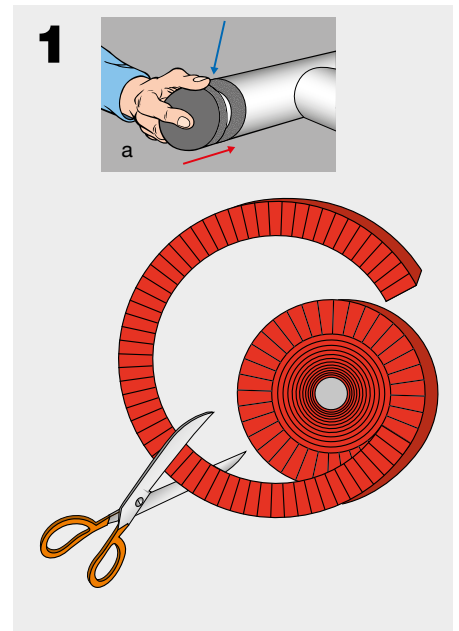

Wind the terminal tape around the end of the insulated pipe, covering the edges of the joint.

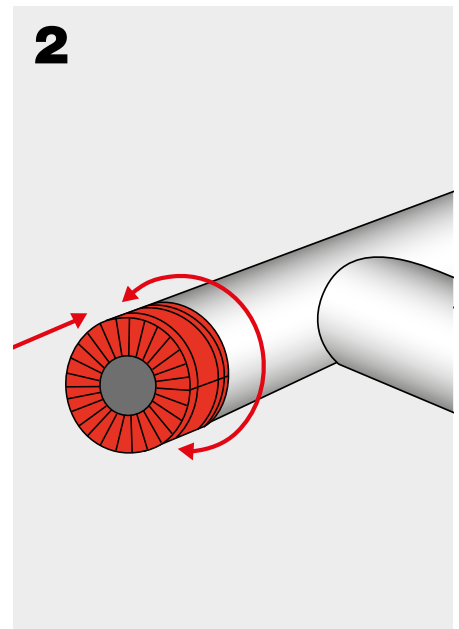

Fix the terminal tape with suitable adhesive tape.

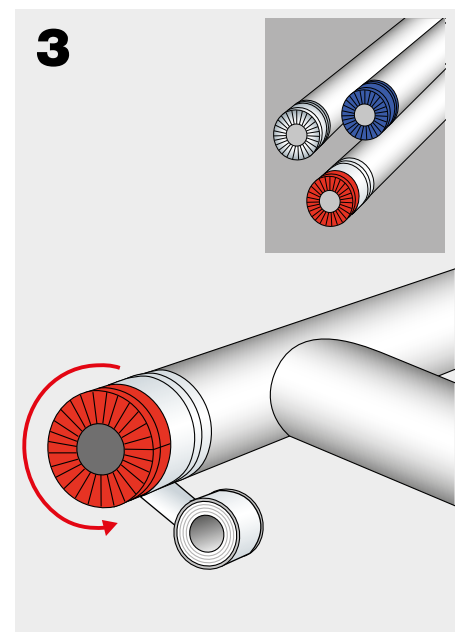

PROTECTING INSULATING TUBING WITH K-FLEX® BLECH MT 500

Prepare K-FLEX® BLECH MT 500 covers of the required diameters and with the number of male/females necessary. The diameter of the cover should be slightly larger than the pipe so it can be easily fitted. Open the cover lengthwise enough to fit it over the piping.

Release the cover so the edges close over the piping. The overlapping edges are for fixing.

Close the edges with short screws in the ready-made holes.

Put the next section on and join to the previous section with the male/female edges.

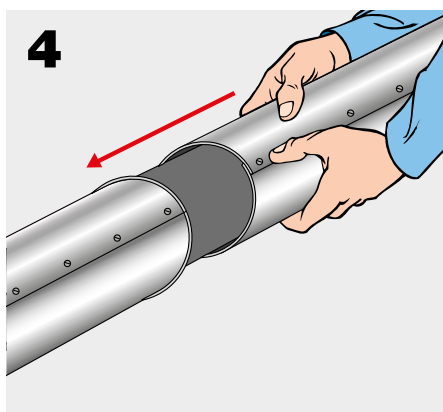
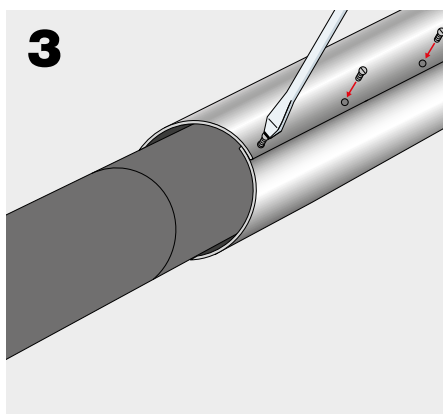
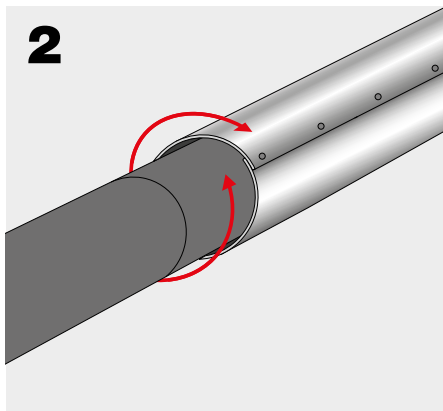
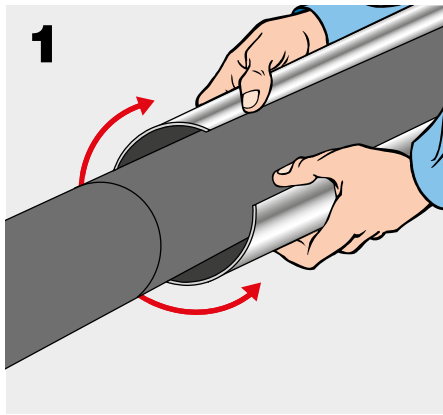

PROTECTING INSULATING BENDS WITH K-FLEX® BLECH CU 501

Open the bend lengthwise enough to fit it over the piping.

Release the bend so it closes over the piping. The overlapping edges are for fixing. Then close the edges with short screws in the ready-made holes (a).

Put the next section on and join to the previous section with the male/female edges.

Repeat the same operation with the opposite section, completing protection of the bend (b).

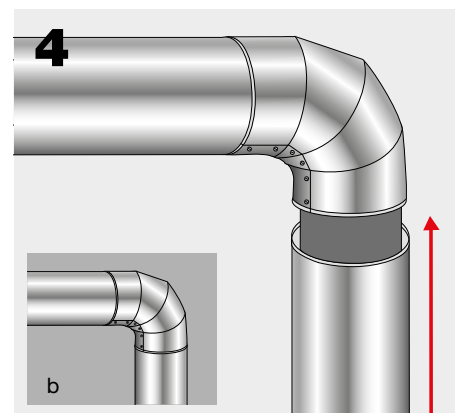
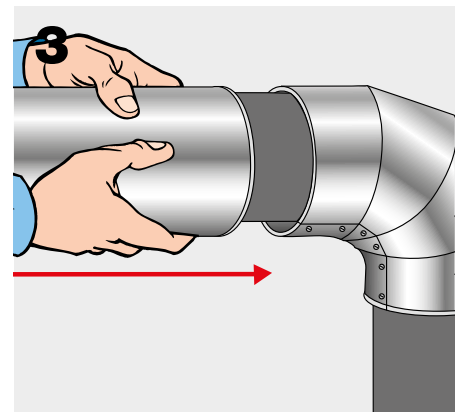
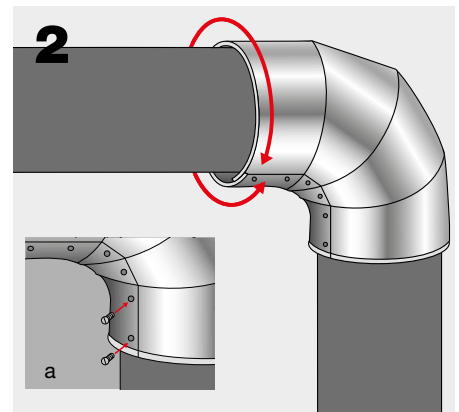
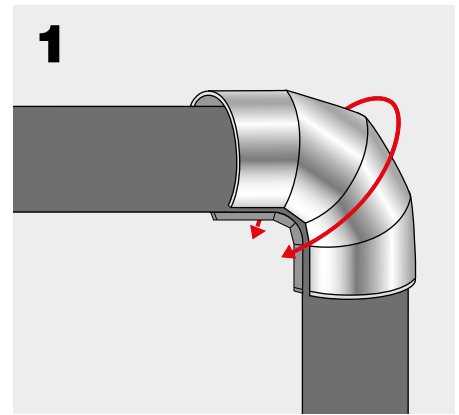

K-FLEX® K-FONIK ST GK

Smooth elastomeric sound insulation panel in various thicknesses, coupled with a high density elastomeric sheet.



Drainage pipes insulation

Wrap a strip of K-FLEX® ST GK of the same thickness as that to be used around the pipe to be insulated and measure the exact length required.

Draw the measure on a K-FLEX® ST GK sheet adding at least 5cm as overlap.

Cut carefully along the line. To ensure accurate results, use a metal ruler.

Measure of circumference of the most common pipe sizes including overlap:

- ø 76 = 37 cm
- ø 90 = 41 cm
- ø 110 = 47 cm
- ø 125 = 53 cm

The sheet or the special pieces must adhere perfectly to the surface and the joints must have an overlap of at least 50 mm; they must then be fixed with PVC adhesive tape, wire or metal/plastic straps.

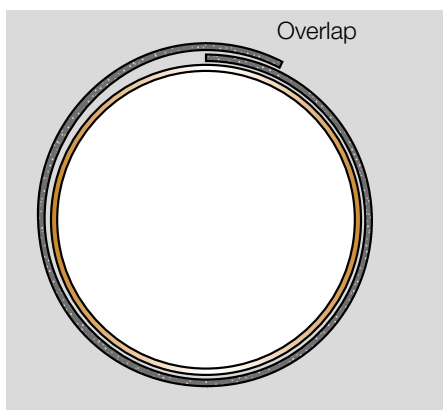
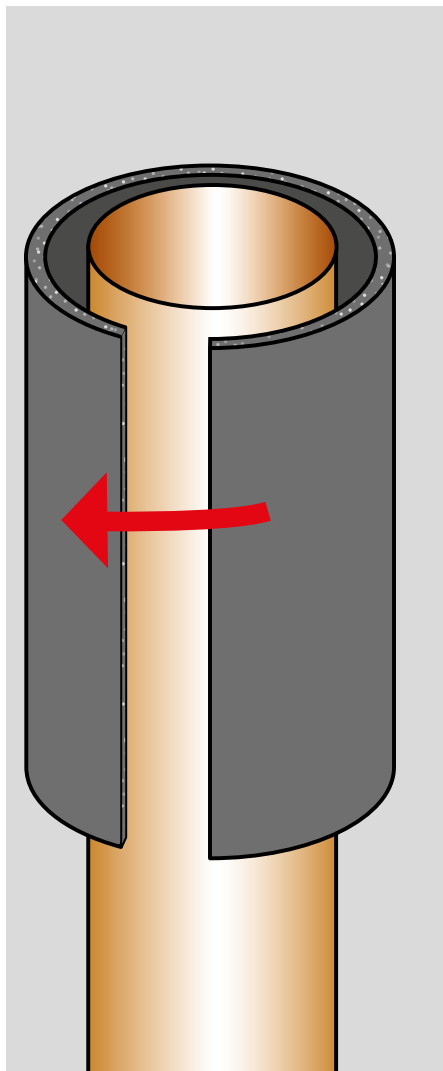

Special pieces insulation

Wrap a strip of K-FLEX® ST GK of the same thickness as that to be used around the pipe to be insulated and measure the exact length required.

Draw the measure on a K-FLEX® ST GK sheet adding at least 5cm as overlap.

Cut carefully along the line. To ensure accurate results, use a metal ruler. Measure of circumference of the most common pipe sizes including overlap:

- ø 76 = 37 cm
- ø 90 = 41 cm
- ø 110 = 47 cm
- ø 125 = 53 cm

The sheet or the special pieces must adhere perfectly to the surface and the joints must have an overlap of at least 50 mm; they must then be fixed with PVC adhesive tape, wire or metal/plastic straps.

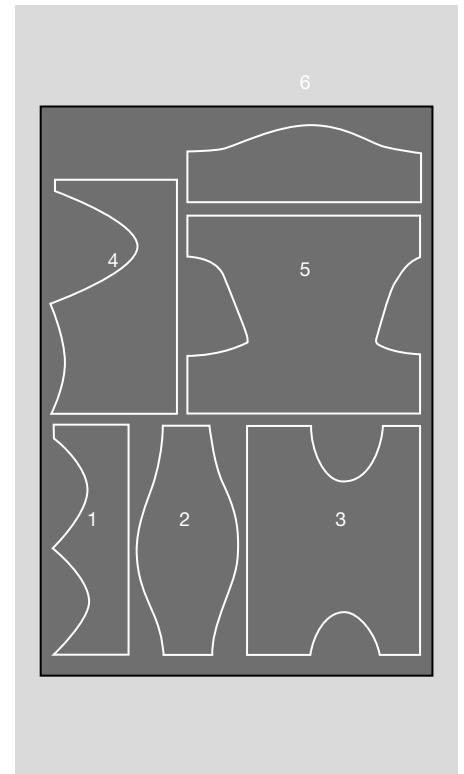

90° BEND

First, apply piece n° 2 onto the bend. Then, place the two n° 6 pieces with the chamfered sides towards the bend to complete the covering.

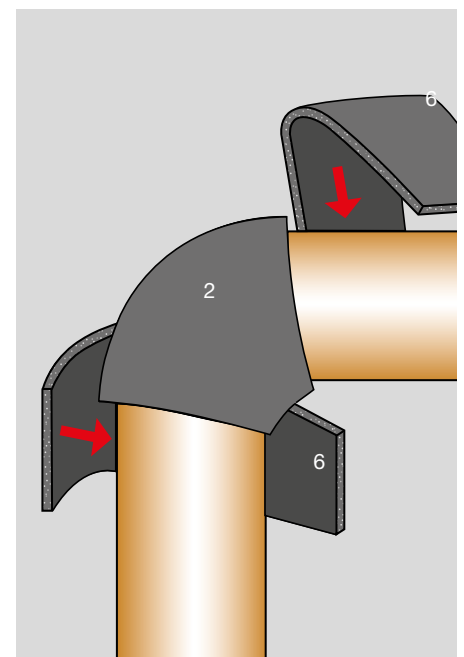

90° BRANCHES

Piece n° 1 is first applied onto the horizontal part of the piping; next, piece n° 3 closes over the branch.

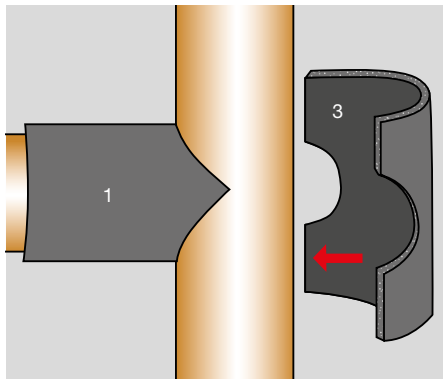

45° BRANCHES

Piece n° 4 is applied onto the oblique arm of the branch. Piece n° 5 completes the insulation.

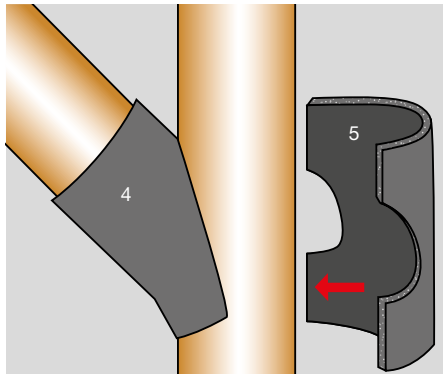

Insulation of metallic panels and casings

Metallic cases of noisy systems can be acoustically insulated using K-FONIK material. Proper thickness must be chosen according to the desired performance. K-FONIK GK/GV up to 2mm thickness (4kg/m²) can be glued directly on the metal surface. Cut the GK/GV panel to the shape needed. Use K-FLEX[®] thinner to thoroughly clean the surface to be insulated. Apply K-FLEX[®] glue to GK/GV and to the metallic surface. Put the GK/GV on the metallic panel. A 50mm overlap between two consecutive panels will give better results avoiding acoustic bridges. For thicker material (over 4kg/m² weight) use additionally a mechanical fixing with screws or pins every 50cm.



Insulation of walls

1) Light plasterboards walls.

Cut the GK/GV panel to the shape needed. Apply K-FLEX[®] glue to GK/GV and to the plasterboard surface. Use screws to fix the plasterboards with GK/GV to the metallic frame.

2) Solid walls

Cut the GK/GV panel to the shape needed. Use nylon plugs and fixing to fix GK/GV to the wall



Installation of K-FONIK OPEN CELL on metallic panels and casings

K-FONIK OPEN CELL up to 25mm can be installed directly glued on metallic substrate. Cut the K-FONIK OPEN CELL panel to the shape needed. Use K-FLEX[®] thinner to thoroughly clean the surface to be insulated. Apply K-FLEX[®] glue to K-FONIK OPEN CELL and to the metallic surface. Put the K-FONIK OPEN CELL on the metallic panel. For thicker material (over 30mm thick) use additionally a mechanical fixing with screws or pins every 50cm. Open Cell can be glued also on GK/GV substrate. Apply K-FLEX[®] glue to K-FONIK OPEN CELL and to the GK/GV surface. Put the K-FONIK OPEN CELL on the panel. For thicker material (over 30mm thick) use additionally a mechanical fixing with screws or pins every 50cm.



3) Installation of K-FONIK OPEN CELL in walls partitions

K-FONIK OPEN CELL can be installed inside plasterboard walls. Place K-FONIK OPEN CELL with proper thickness according to the application within the metallic structure of the wall and provide mechanical fixing with screws.

K-FLEX® K-ROCK



The mineral wool insulation pipe section with aluminum covering is slit on one side and can be wrapped around the pipe to be insulated.



Before sealing, the mineral wool pipe section must be pressed together exactly. It is important to ensure that all adhesive points are free of dust, grease, and moisture before closing the adhesive tape!



The longitudinal joint can then be sealed with the factory-fitted longitudinal overlap. Ensure the Adhesive overlap is pressed on well to ensure complete adhesion.



To minimize heat loss when installing horizontally, align the longitudinal seam so that it is at the bottom of the pipe! ¹⁾

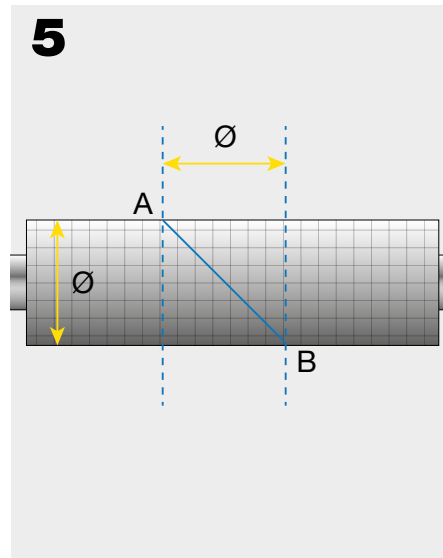

At an angle of 90°, cut through the mineral wool pipe section at an angle of 45° as described below - make sure that the longitudinal seam is at the top. Make two parallel markings in the middle of the mineral wool pipe section, the distance between them corresponds to the dimension of the outer diameter of the insulation and cut diagonally from A to B through the mineral wool pipe section.

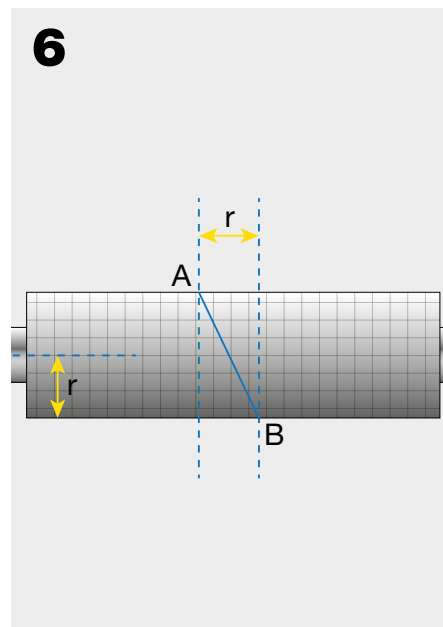

At an angle of 45°, cut the mineral wool pipe section in the middle at an angle of 22.5° - taking care that the longitudinal seam is at the top. Make two parallel marks in the middle of the mineral wool pipe section, the distance between them corresponds to the radius of the insulation and cut diagonally from A to B through the insulation pipe section. Then seal the butt seams with suitable adhesive tape.

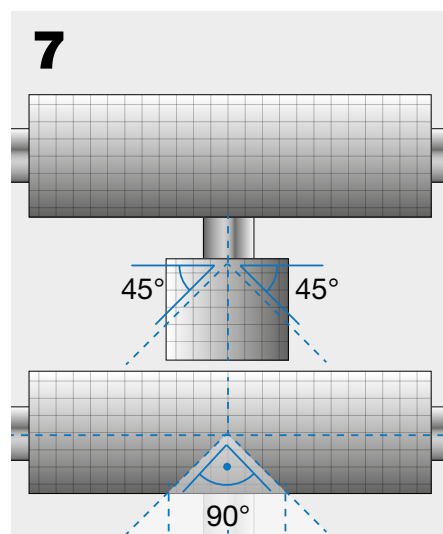

In the case of T-pieces with 90°; cut the mineral wool pipe section of the outgoing pipe to a point, using two 45° cut starting from the center point. Then cut a wedge of 90° from the center of the mineral wool pipe section length. The width of the cut-out part should correspond to the outer diameter of the pipe shell.

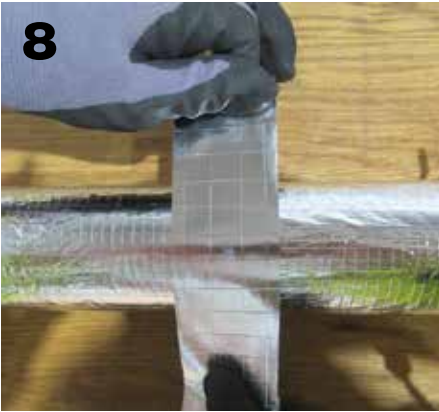

8
Cross joints of the mineral wool pipe sections are to be fixed without any gaps and additionally secured with suitable adhesive tape supplied by the manufacturer.



9
It is recommended to additionally secure the mineral wool pipe section with aluminium bands or soft galvanised binding wire.²⁾

EXPERT TIPS:

- ▶ Avoid continuous exposure to the sun in the case of film-coated trays.
- ▶ For pipes with low medium temperatures, the pipe shell must be provided with a continuous vapour-tight outer jacket barrier.
- ▶ All surfaces must be dry, free of dust and grease.
- ▶ Store trays in a warm environment before processing in the cold season (to avoid surface condensate).
- ▶ Always start with pipe bends and T-pieces.
- ▶ Always bind joints with color-matched adhesive tape so that they are tight.
- ▶ The processing temperature of the self-adhesive trays and the associated adhesive tapes is +10 °C to +35 °C Always overlap the adhesive tapes!
- ▶ Mineral wool pipe trays are not suitable for outdoor use.

¹⁾ This prevents tensile stresses due to the weight of the shell on the adhesive points. Tensile stresses on the overlap bond must generally be avoided!

²⁾ At ambient temperatures above 40 °C and in the case of subsequently inaccessible cables, the mineral wool sections must also be secured with aluminium bands or binding wire!

K-FLEX® PU

Open the cover along the longitudinal cut and put it on the insulated pipe. Fit the casing to the pipeline by pressing it against the pipe in order to eliminate leaks. Lay the cover in such a way that it is possible to have access to the factory cut.

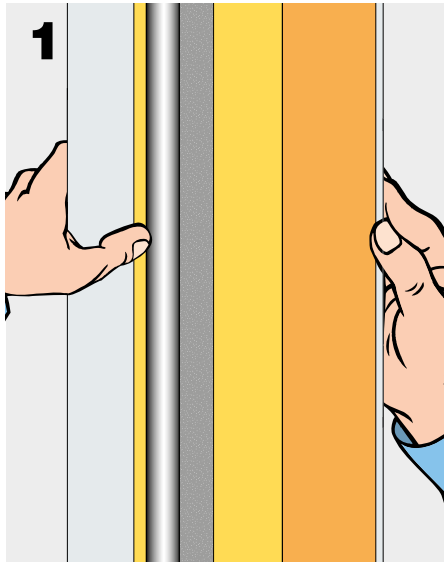

The contact points of the cuts and lagging connections can be additionally sealed with K-FLEX® plastic rivets.

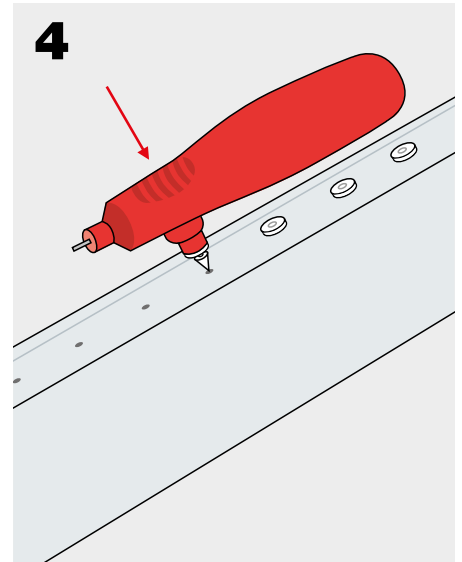

First, remove the securing strips from both glued edges, then bring both edges closer together and press firmly. Seal the connection of the longitudinal cut with the self-adhesive overlap on the cover.

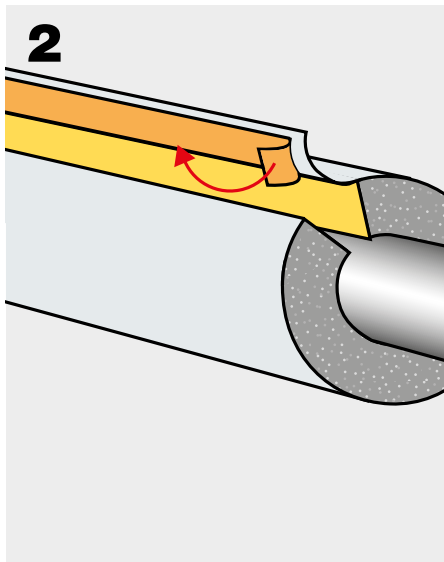

ENDCUPS

To ensure a clean finish of the insulated pipes, use K-FLEX® colored endcaps. The endcaps are fixed with K-FLEX® PVC AT 070 self-adhesive tape.

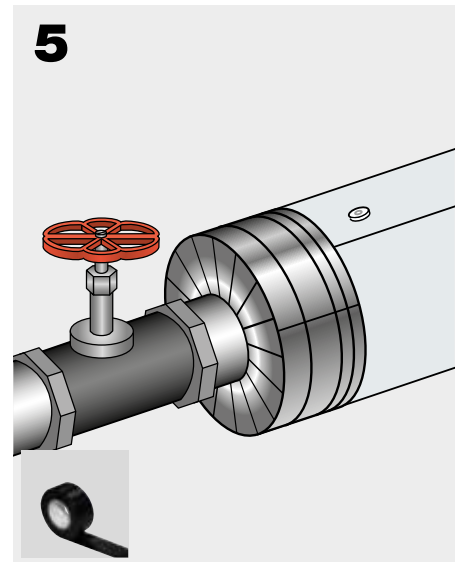

In the case of long straight sections of the pipeline, the lagging should be joined by adjusting them to each other, and then the transverse connection should be secured with K-FLEX® self-adhesive PVC tape.

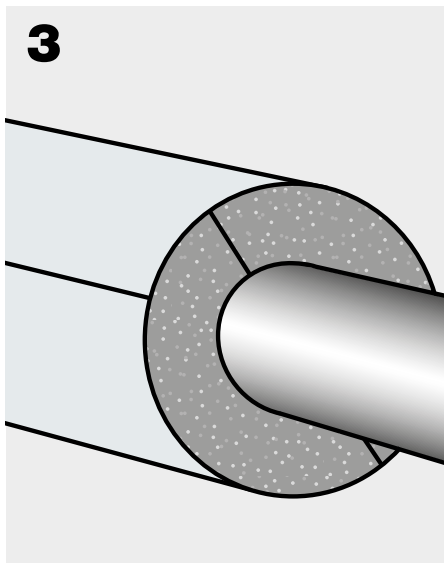

ELBOWS

Two parallel points should be marked on the cover, the spacing of which is equal to the outer diameter of the cover. Then cut the cover as shown in the drawing - from the previously determined point A to point B.

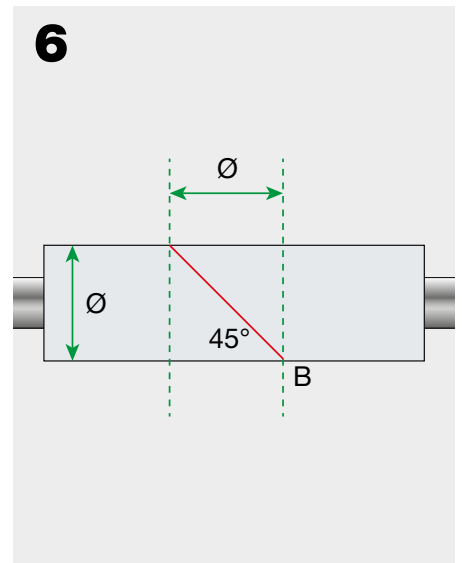

Put one of the cut sections of the pipe covering on the pipeline, press it down and seal it with a self-adhesive tab. Turn the second cut section by 180° and put it in the same way as the previous one, so that both u form a right angle.

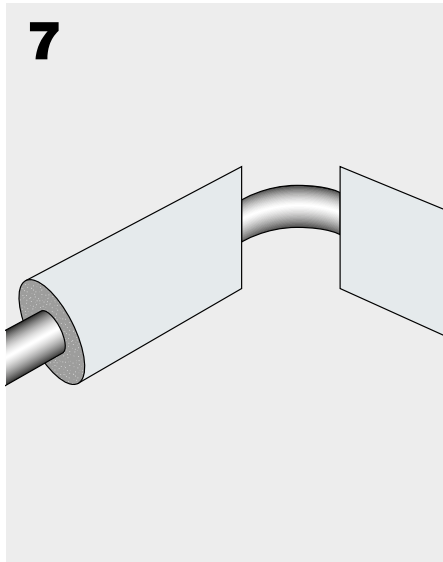

Ready-to-install elbows can be used to insulate the pipeline at an angle of 90° in the K-FLEX® PU. That's enough mount them on the pipeline and seal it with K-FLEX® PVC AT 070 self-adhesive tape in the appropriate color.

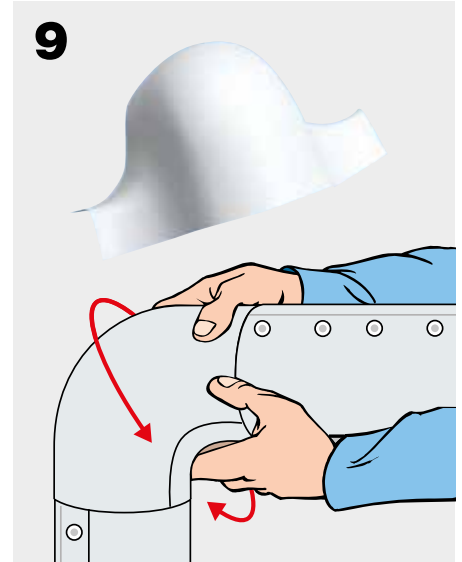

Carefully align the two sections and seal their joint with K-FLEX® PVC AT 070 self-adhesive tape.

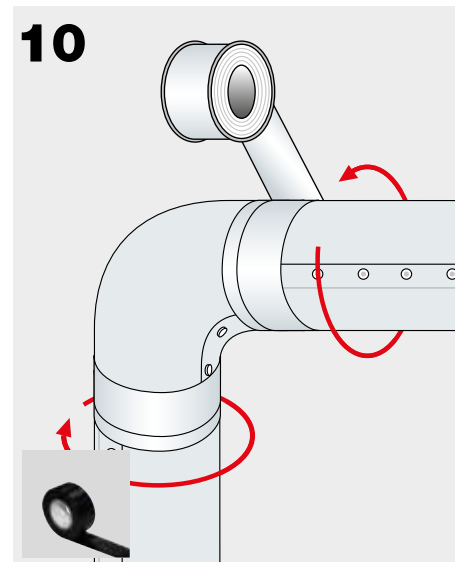
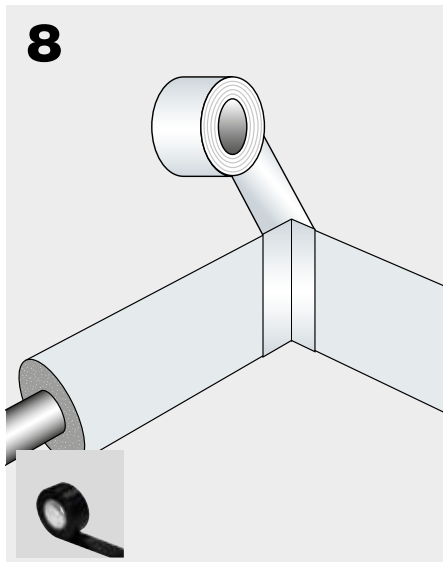

K-FLEX® FONOMETAL

INSULATION OF STRAIGHT PIPES

Slit the K-FLEX® FONOMETAL tube lengthwise, place the open sleeve around the pipe and secure all seams with self-adhesive K-FLEX® CLOTH DUCT Tape.

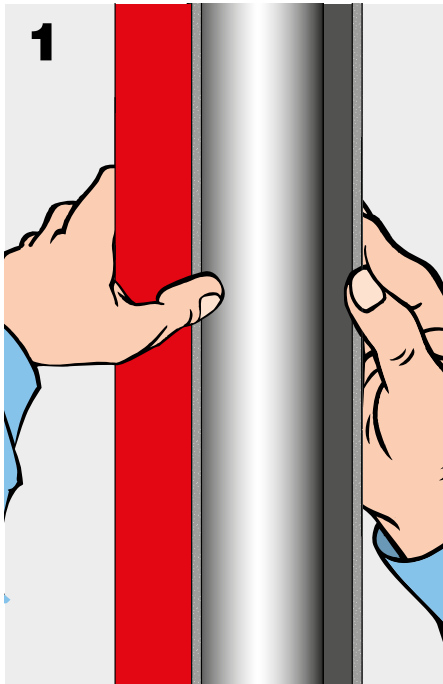

Use K-FLEX® CLOTH DUCT Tape to secure the butt joints of the insulation.

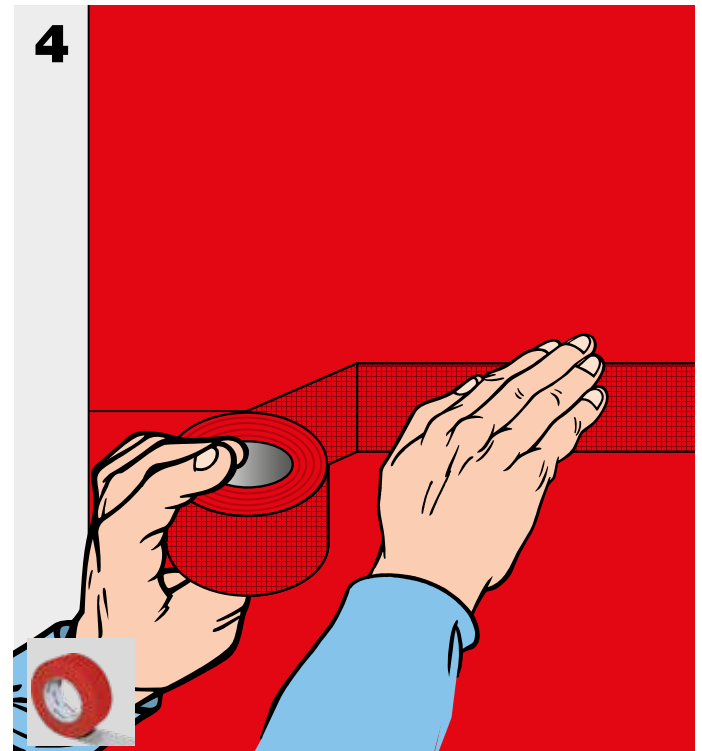
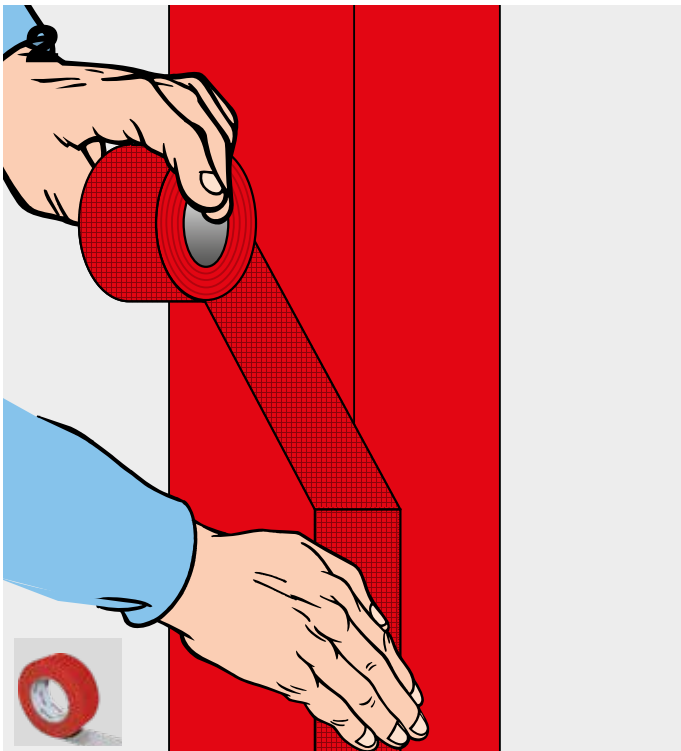
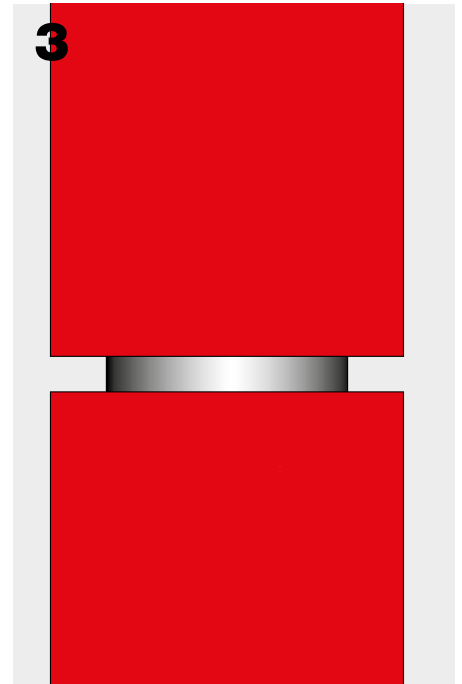

INSULATION OF ELBOWS AND JOINTS

Insulate the pipe up to the bend / branch pipe. Wrap TK-FLEX® CLOTH DUCT Tape around the bend / branch allowing it to overlap slightly.

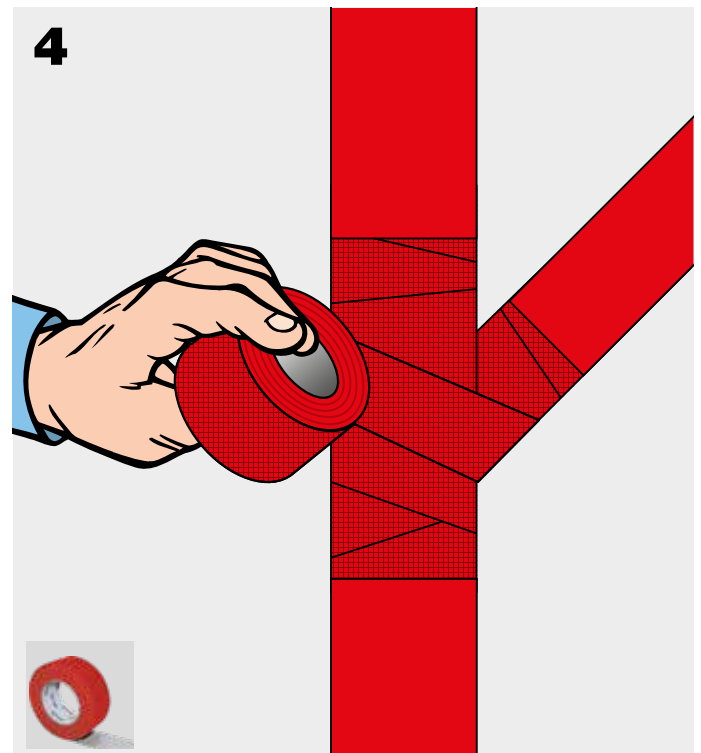
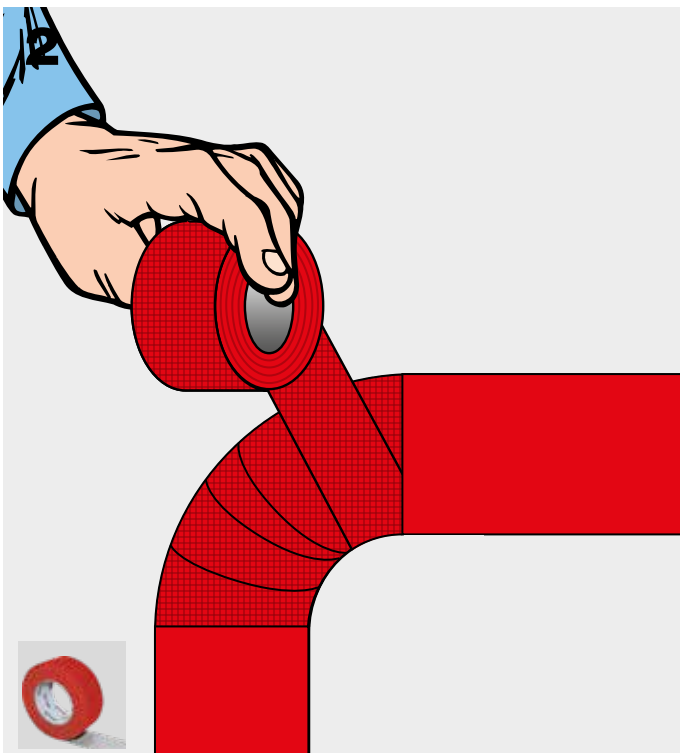
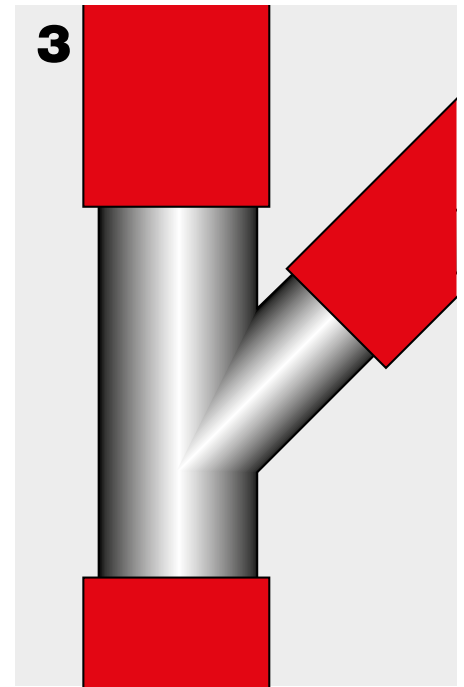
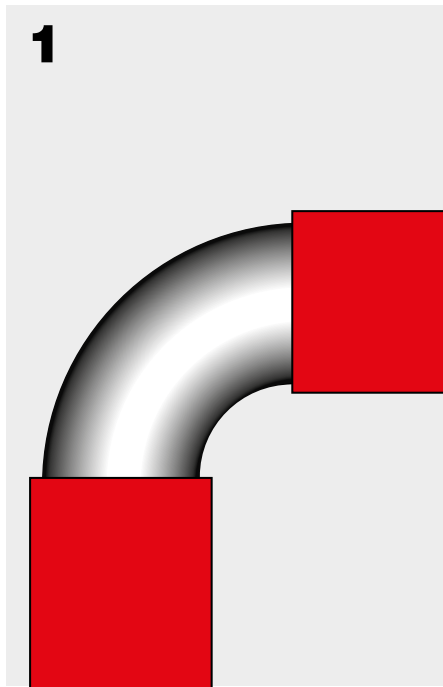

**INSULATING
WASTEWATER
PIPES**

**Simplified segment
bend**

Cut a K-FLEX® tube to the right length to cover the elbow. Cut it in the middle at an angle of 45°. Use the K-FLEX® cutting board as a template for the angle of the cut. A long-bladed knife is required.

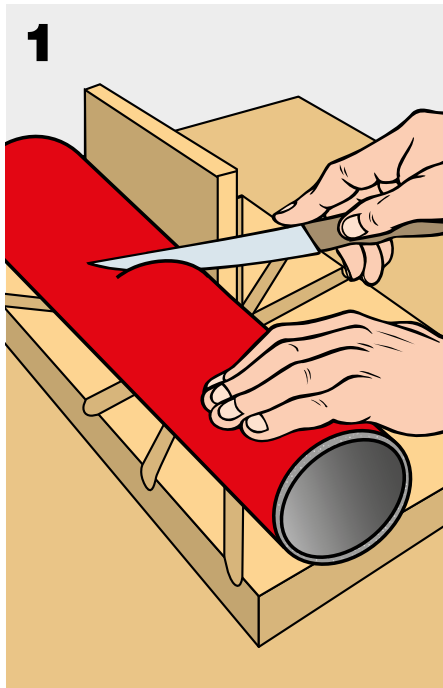

Position it on the pipe and seal the two edges.

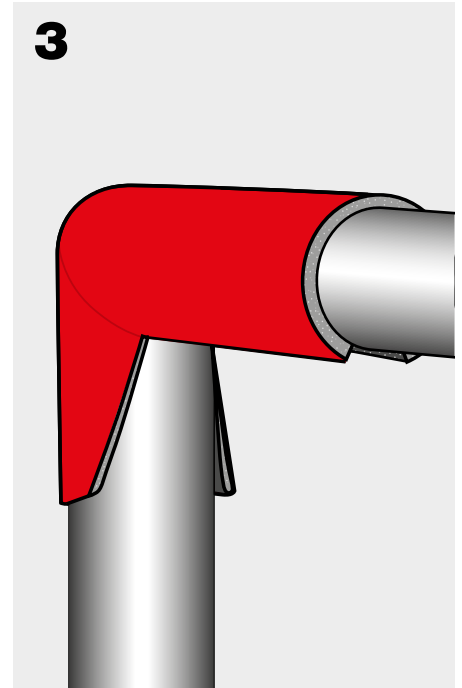

Twist one of the pieces of tube until you form a 90° angle.

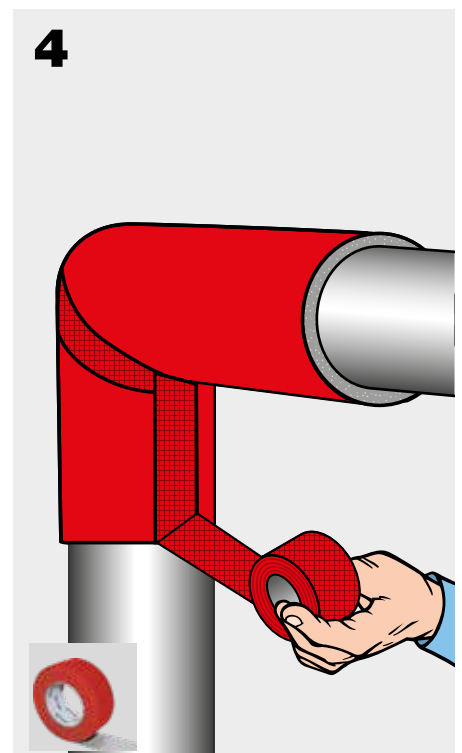
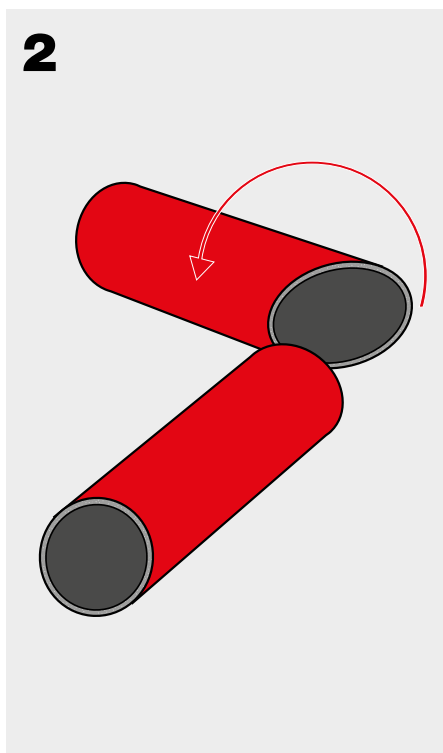

INSULATING A T-FITTING with a round insert

Using a punch or metal tube with a cutting edge of the same diameter as the tubing, make a hole in the insulating tubing at the point where the "T" is to be formed.

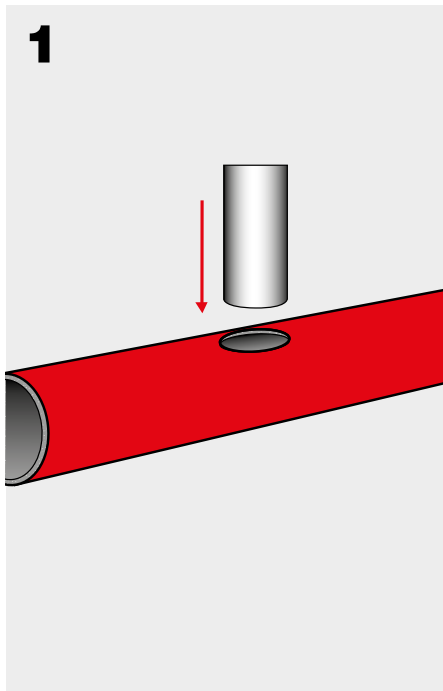

The joint for the lower branch is created by cutting a U-shaped section from a second piece of tubing.



Cut the tube along its length and slide it onto the pipe so that the hole is positioned around the third pipe. Then stick the edges back together.

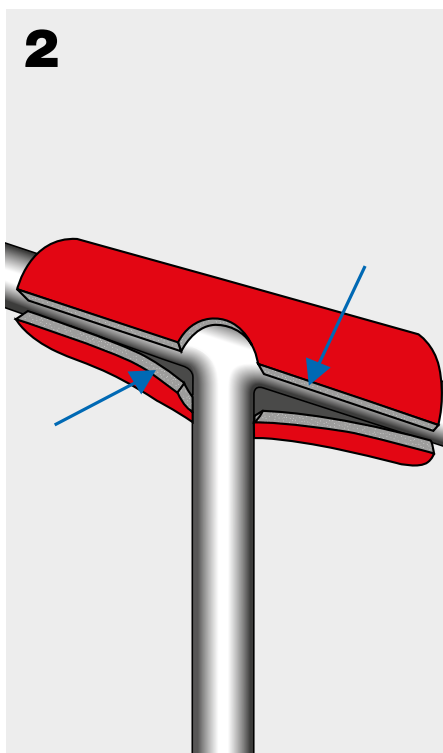

Align the lower tube so that it fits the hole in the upper section snugly and seal the whole together.

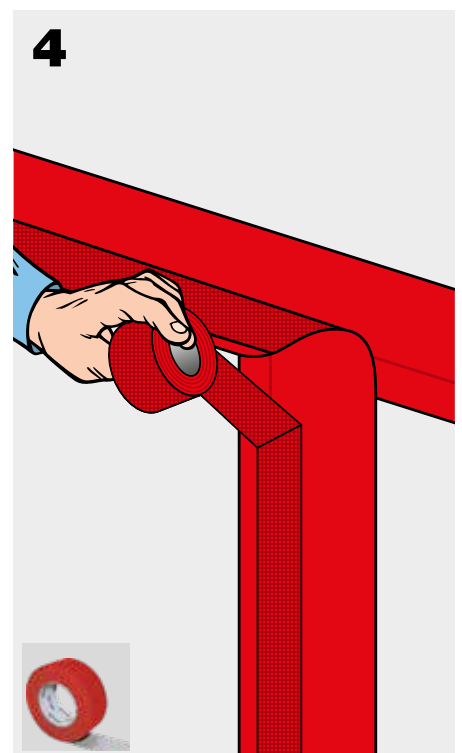

CONTACT

L'ISOLANTE K-FLEX S.p.A.

Via Don Locatelli, 35 - 20877 Roncello (MB) Italy

T +39 039 6824-1

F +39 039 6824-560

E internationalsales@kflex.com

www.kflex.com



WE INNOVATE TO CREATE
MORE EFFICIENT, SAFE
AND COMFORTABLE PLACES
AROUND THE WORLD

© K-FLEX® - INT_MAN_1025
K-FLEX® reserves the right to change data and technical requirements without notice.